

# CPC12 ControlPlex<sup>®</sup> System

## Unrivalled uptime in machine construction and process control



**PROFI**<sup>®</sup>  
**NET**

**EtherCAT**<sup>®</sup>

# CPC12 ControlPlex® System

## Transparency across all levels of the automation pyramid

Requirements regarding product quality and stability of the production process are constantly rising in machine construction and process control. The CPC12 ControlPlex System offers permanent data logging, analysis and processing. This provides the required transparency to detect any changes in the production process at an early stage and to take countermeasures in time.

Consistency of the systems is particularly important. Besides the field bus interfaces PROFINET and EtherCAT, the CPC12 bus controller also has another Ethernet interface. It allows access to the system even without fieldbus. Direct access to the integral web server of the device is made possible.

All data and information are available on the device on site, but also in the office. If the circuit protector has tripped, it can quickly be reset to operation. Downtimes are reduced and machine uptime is increased. Data can easily be analysed and evaluated later by means of remote access.

The modular REX system is especially adapted to the special requirements of machine construction and process control. The CPC12 bus controller extends the REX system by the connection to different fieldbus connections. This makes your DC 24 V power distribution and protection more transparent than ever.

The REX12D electronic circuit protector records status and measuring values of each load circuit and transmits them to the bus controller. System operators and maintenance staff thus receive all information they need to detect changes and possible undesirable developments at an early stage.

### Remote Maintenance

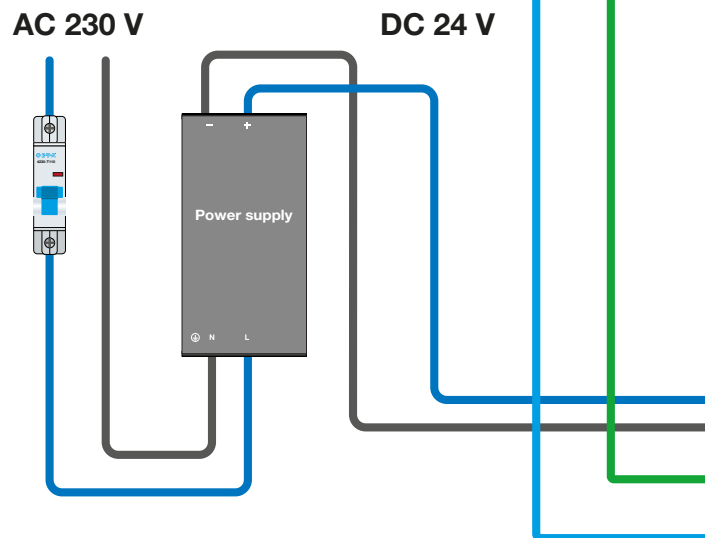

*With the CPC12 bus controller, the REX system creates transparency across all levels of the automation pyramid*

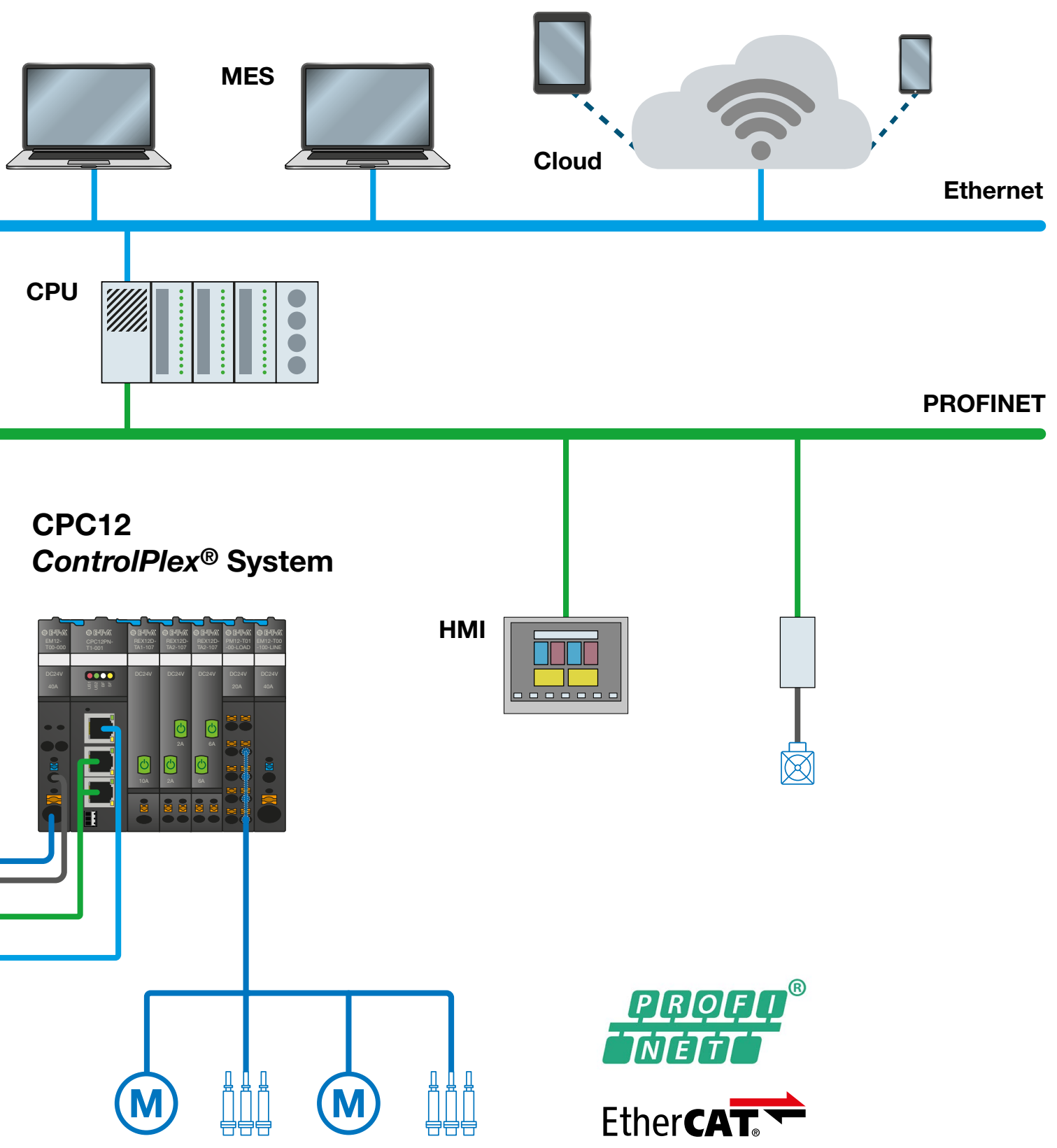

# Versatile and intelligent DC 24 V power protection

## Tailor-made for your individual requirements

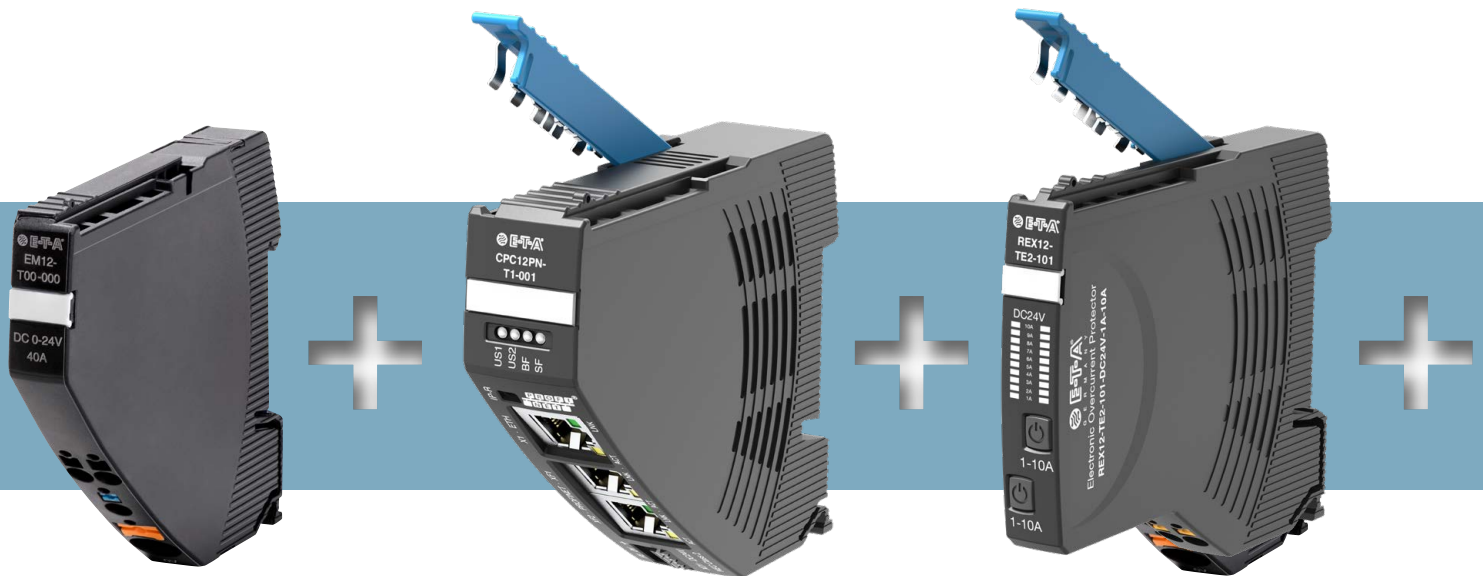

### EM12-T supply module

#### Compact und flexible

The **CPC12 ControlPlex® system** provides you with the ideal combination of transparency and compact design. Up to 40 A can be fed into the supply module. Power is further distributed without further accessories via the REX connection technology with connector arm to the connected circuit protectors. This innovative technology reduces wiring time and eliminates time-consuming disassembly of busbars in the event of replacement or system extension.

### CPC12 bus controller

The **CPC12** bus controller is connected with the **EM12-T** supply module. It has a separate DC 24 V power supply and thus allows an independent supply of the circuit protectors. The bus controller records all status information and measuring values of the circuit protectors. These data are visualised with the internal web server. Via the field bus interface, the data are also made available to the superordinate control systems.

### REX12D circuit protector

The **REX12D** electronic circuit protector has especially been designed for process control and machine construction. The version with fixed current ratings features protection in compliance with the EN60201-1 standard. Here the current rating of the fail-safe element is equal to the current rating of the circuit protector. With other version, the current ratings can be adjusted via the bus controller between 1 A and 10 A, thus reducing storage costs. This also allows quick adjustment of the current rating in the event of changes in the system configuration.

# Compact. Mod

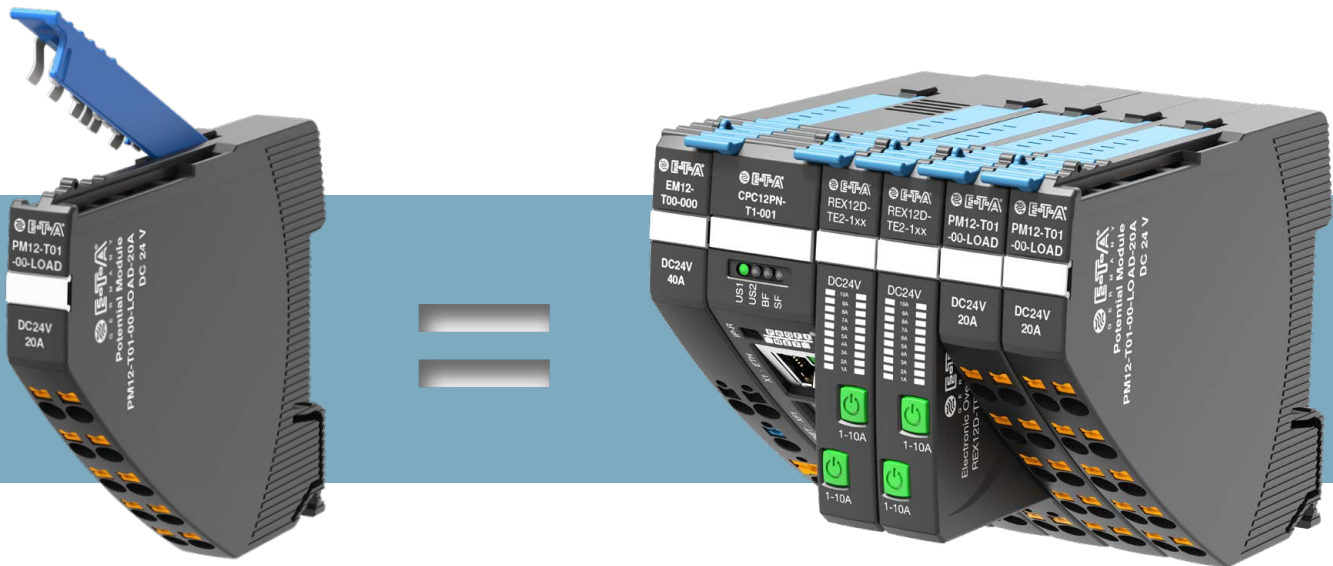

## PM12-T potential module

The **PM12-T** potential modules of the REX system are mounted side-by-side with the **REX12D** circuit protectors. After having connected the protected output of the **REX12D** with the potential module, the output can be multiplied. Thus it is possible to create groups of loads. The clear layout of the DC 24 V power distribution is enhanced by the precise assignment to the circuit protectors and it eliminates conventional terminal blocks.

## CPC12 ControlPlex® System

### Quick access through integral web server

The integral web server of the **CPC12** bus controller allows direct access to the data of the DC 24 V power distribution. All measuring data and status information can directly be accessed without using the field bus interface. This is particularly advantageous for the maintenance personnel, because information is quickly available during initial start-up and in the event of a system shutdown.

## Your benefits

- **Increases plant and machine uptime** through clear failure detection, high transparency and remote diagnosis
- **Saves space** through the slim design of the circuit protectors and potential modules
- **Increases flexibility in planning a plant** due to the a range of different modules

# ular. Intelligent.

# CPC12 bus controller in REX format

## Transparency through web server and fieldbus connection

### Connection technology

Matching the REX system, this connector arm connects the different modules with each other. No additional accessories are required.

### Status indication on the device

The operating condition of the device can be read any time via the LEDs.

### IP reset

By operating the IP reset button, the IP address is reset to the default value.

### Integral web server

The integral web server allows direct access to all data of the **CPC12 ControlPlex®** system.

### Field bus connection

The connection to PROFINET and EtherCAT provides transmission of measuring values and status information to the superordinate control systems as well as remote control of all circuit protectors.

### Separate power supply

Voltage supply of the devices is separated from the load circuit of the system. The bus controller is supplied separately.



*The CPC12 bus controller offers a wealth of features: from the integral web server to a separate voltage supply*

# Intelligent REX12 system

## For unrivalled system availability

### Continuous data collection

The double channel REX12D electronic circuit protector records the status and its measuring values such as the load current. These pieces of information are transmitted to the superordinate control unit and are processed there to be displayed on the connect visualisation units. The rising transparency provides the maintenance personnel with an overview over the current state of the DC 24 V power distribution.

### Early warnings by way of a limit value

The REX12D circuit protector has a parameterisable limit value. This value can be adjusted to a value between 50% and 100% of the current rating. If the value is exceeded, this is displayed directly on the device. A warning message is also transmitted to the superordinate control unit and displayed. The maintenance personnel can be informed of critical changes in the system behaviour at an early stage and can respond before the failure happens.

### Adjustable design reduces inventory

The current rating of the REX12D-TE2 can be adjusted from 1 A to 10 A in integer numbers. This functionality enormously reduces inventory. You need only one device for all current ratings. Parameterisation is effected via the superordinate control unit and can also be fixed there. This prevents inadvertent change of the current rating.



Parameterisation of the circuit protectors possible via HMIs



# CPC12 protection for industry 4.0

## condition monitoring – predictive maintenance

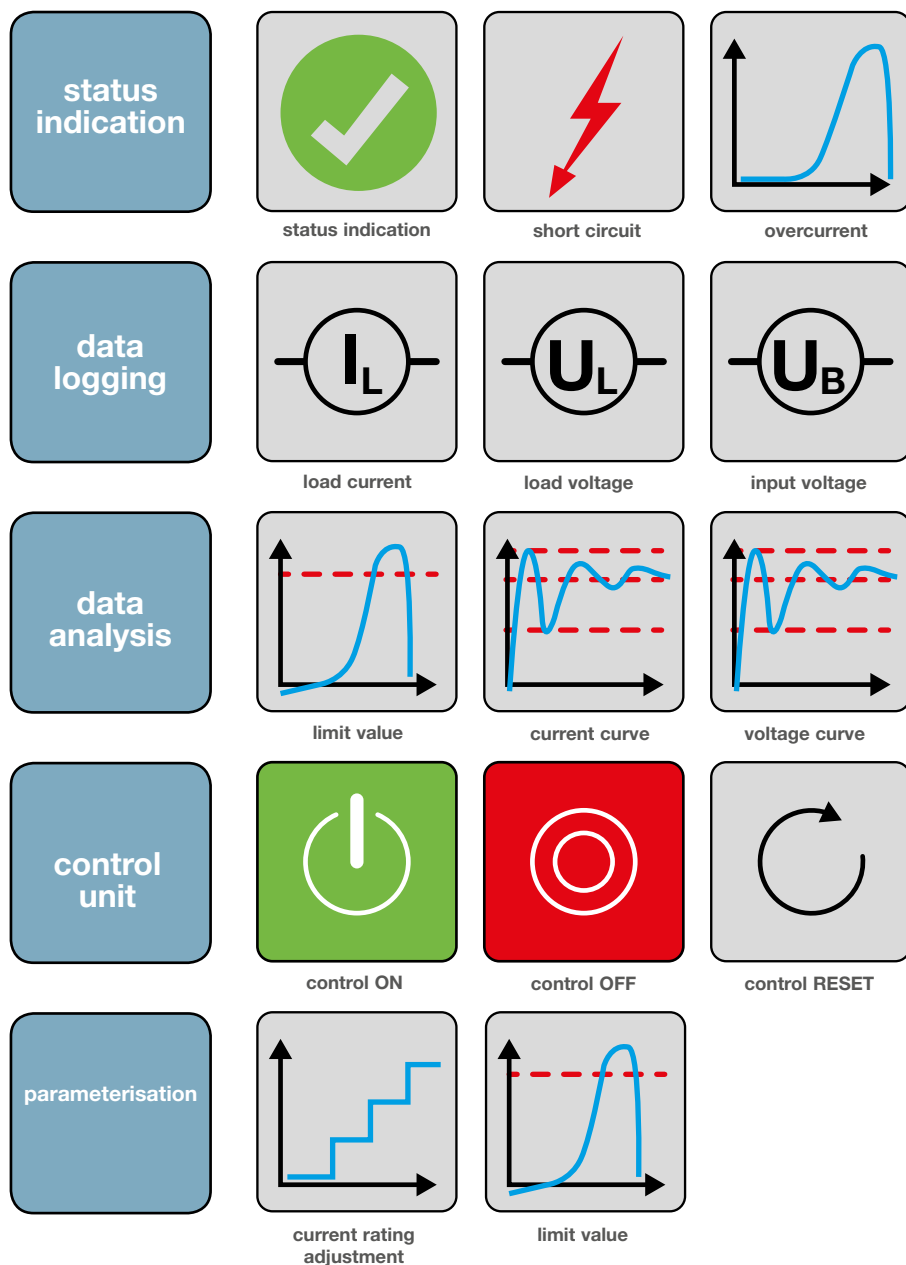

E-T-A Elektrotechnische Apparate GmbH  
 Industriestraße 2-8 · 90518 ALTENDORF  
 GERMANY  
 Phone +49 9187 10-0 · Fax +49 9187 10-397  
 E-mail: info@e-t-a.de · www.e-t-a.de

B\_CPC12\_e\_040320A

Technical changes, misprints and errors reserved.  
 Photos: E-T-A, cover: © Nataliya Hora/Fotolia.com