

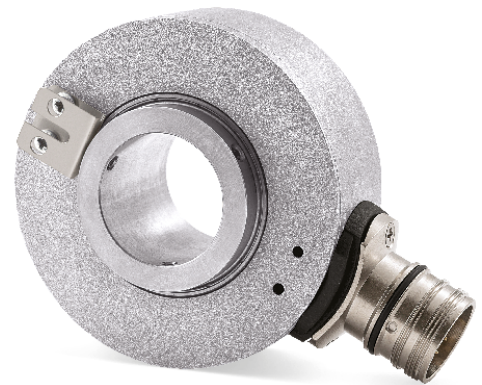

- Feedback encoder for big size motors
- Precise optical sensing
- Very flat design
- Through hollow shaft up to  $\varnothing$  30 mm
- Robust die cast housing with IP65 protection



C80

### ENVIRONMENTAL SPECIFICATIONS

Shock:	250 g, 6 ms acc. to CEI EN 60068-2-27
Vibrations:	10 g, 5-2000 Hz acc. to CEI EN 60068-2-6
Protection:	IP64
Operating temperature range:	-25°C +85°C (-13°F +185°F)
Storage temperature range:	-40°C +100°C (-40°F +212°F) (98% R.H. without condensation)
Options:	<ul style="list-style-type: none"> <li>• Operating temperature range: -40°C +100°C (-40°F +212°F)</li> <li>• IP65 Protection (3000 rpm max, torque 2 Ncm)</li> </ul>

### MECHANICAL SPECIFICATIONS

Dimensions:	see drawing
Hollow shaft diameter:	$\varnothing$ 25, 30 mm
Reducing sleeves, BR2-xx from $\varnothing$ 30 mm to:	$\varnothing$ 15, 5/8" (15,875), 16, 17, 18, 19, 20 22, 23, 24, 1" (25,4), 28 mm
Shaft loading (axial and radial):	30 N max.
Shaft rotational speed:	6000 rpm max.
Starting torque at 20°C:	$\leq$ 1,5 Ncm (typical)
Bearings life:	400 x 10 <sup>6</sup> rev. min. (10 <sup>9</sup> rev. min. with 20 N shaft loading max.)
Electrical connections:	M23 12 pin plug or cable output 1 m (3.3 ft)
Weight:	$\sim$ 300 g (10,6 oz)
Option:	• additional cable

### ELECTRICAL SPECIFICATIONS

Resolution (PPR):	12-100-200-360-400-500-600-1000-1024-2000-2048-2500 4096
Counting frequency:	100 kHz max.
Output circuits:	Push-Pull, Line Driver, Universal circuit
Power supply:	+5V $\pm$ 5%, +10V +30V, +5V +30V
Consumption:	70 mA (typical)
Output current (each channel):	40 mA max.
Protection:	against inversion of polarity and short-circuit (except L circuit)
EMC:	electro-magnetic immunity, according to: EN 61000-4-2 EN 61000-4-4
Optoelectronic life:	100.000 hrs min.

### MATERIALS

Flange:	die cast aluminium, UNI EN AC-46100
Housing:	die cast aluminium, UNI EN AC-46100
Bearings:	ABEC 5
Shaft:	stainless steel, non-magnetic 1.4305 (UNI EN 10088-1)
Light source:	GaAl diodes

### PREFERENTIAL MODELS

C80-H-1024ZCU430L2	1024 PPR, HTL/TTL output
C80-H-2048ZCU430L2	2048 PPR, HTL/TTL output

### ACCESSORIES

EDE9S:	9 pin DSub mating connector
BR2-xx:	reducing sleeves
EPFL121:	12 pin M23 mating connector

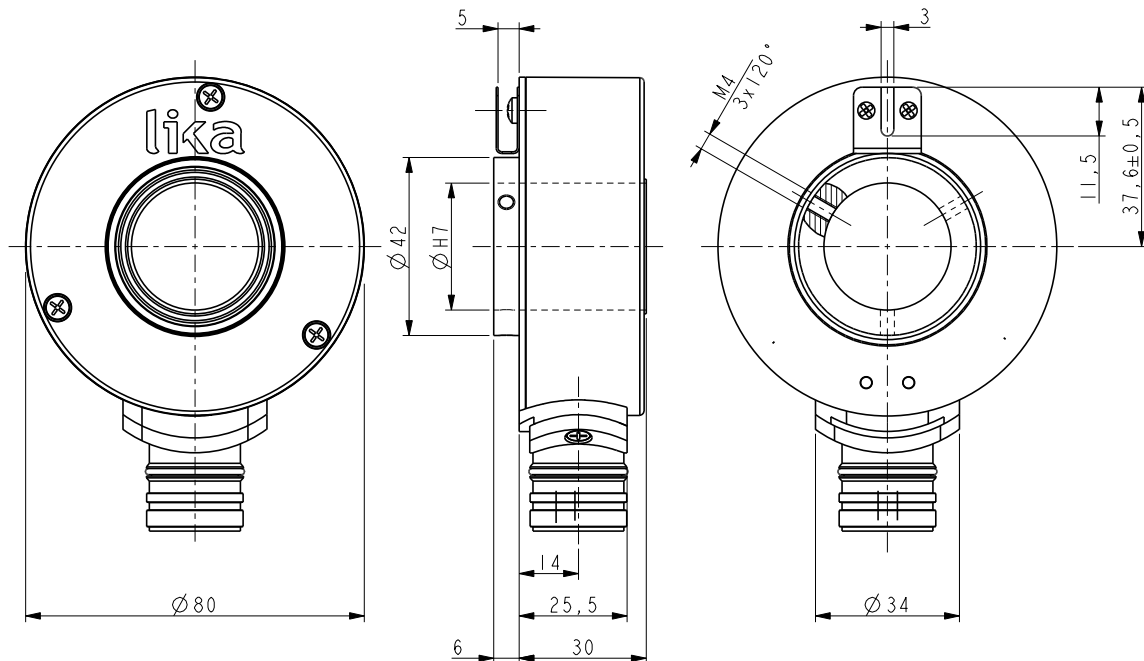

C80

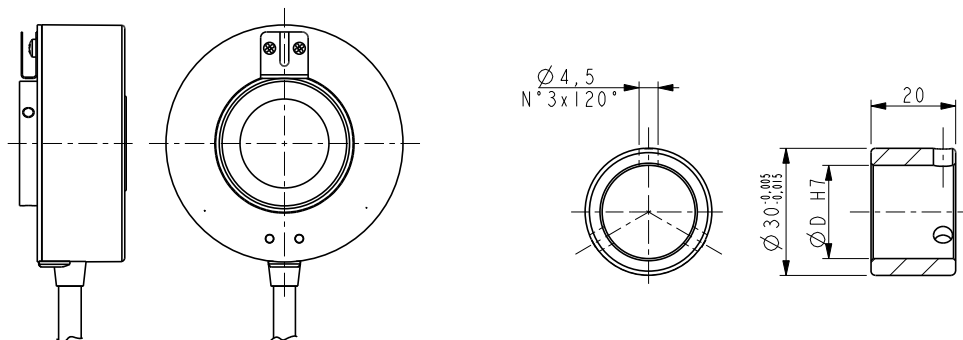

BR2-xx

Order code

C80	-	X	-	XXXXX	XXX	X	XX	X	X	XX	/Sxxx
		(a)		(b)	(c)	(d)	(e)	(f)	(g)	(h)	(i)

<p><b>(a) OUTPUT CIRCUITS</b>                  Y = Push Pull                  L = Line Driver (RS422)                  H = PP/LD universal circuit</p> <p><b>(b) RESOLUTION (PPR)</b>                  See electrical specifications</p>	<p><b>(c) OUTPUT SIGNALS / CONNECTIONS</b>                  BNF = AB, cable output                  ZNF = ABO, cable output                  BCU = AB /AB, cable output                  ZCU = ABO /ABO, cable output                  BCZ = AB /AB, M23 12 pin plug                  ZCZ = ABO /ABO, M23 12 pin plug</p> <p><b>(d) SUPPLY VOLTAGE</b>                  1 = +5V±5% (L output circuit)                  2 = +10V÷ +30V (Y output circuit)                  4 = +5V÷ +30V (H output circuit)</p>	<p><b>(e) SHAFT DIAMETER</b>                  25 = 25 mm                  30 = 30 mm</p> <p><b>(f) PROTECTION</b>                  - = IP64 (standard)                  P = IP65</p> <p><b>(g) OPERATING TEMPERATURE</b>                  - = -25°C +85°C (-13°F +185°F)                  K = -40°C +100°C (-40°F +212°F)</p>	<p><b>(h) CABLE LENGTH</b>                  - = cable output 1 m                  L2 = cable output 2 m                  L7 = cable output 7 m                  Lx = cable output x m (max. 10 m)                  CLx = x m cable with DSub 9 pin inline plug</p>
--	--	---	--

**(i) CUSTOM VERSION**