

## OPTIMUM PROTECTION FOR MAN AND MACHINE

Safety technology is a major topic in mechanical engineering and plant construction. Murrelektronik supplies the best fieldbus components with passive safe outputs for MASI, Cube67, and MVK Metal. These modules are suitable for applications up to Performance Level e, according the EN 13849-1 standard.

Passive safety technology combines today's safety technology with reliable standard fieldbus modules. This facilitates machine installations so you have the latest proven concepts and principles in your system. Existing knowledge is used and no time-consuming rethinking is required making access to this technology easier.



In this safety circuit, a safety relay is operated by an emergency stop button. The safety relays switch off the safe outputs of the fieldbus module.

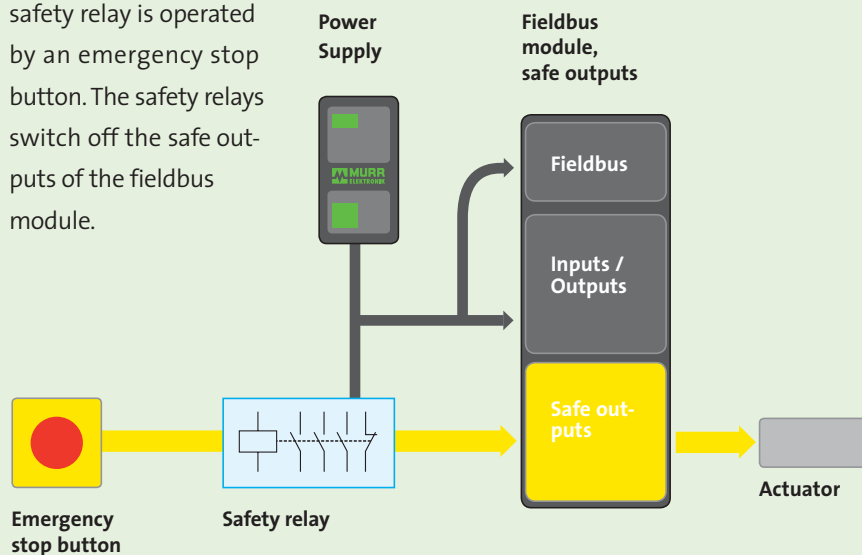

Murrelektronik's fieldbus components for MASI, Cube67, and MVK Metal meet the requirements of the...

... **current EN 954-1 standard:** They are suitable for applications up to Category 3.

... **succeeding EN 13849-1 standard:** Due to fault exclusion no dangerous failures can occur, because the components meet the requirements as explained in the EN 13849-2 standard. The passively safe fieldbus modules keep air and creepage distances. The circuit boards have spaces wide enough to exclude cross circuits. These measures ensure that no external power can interfere with the system after it has been switched off and after the safety function has been released. In this case it is not the signal that has to be considered as safe, however, the groups are safely switched of. It is always the safety relays that release the safety function with the supply voltage of the outputs. Technically this means: The MTTFd value represents the average time until a dangerous failure becomes infinitely high. Keeping this in mind, these products do not have to be taken into account when calculating the DCavg.



### Example: 1 Safety circuit with 2 actuators in a row

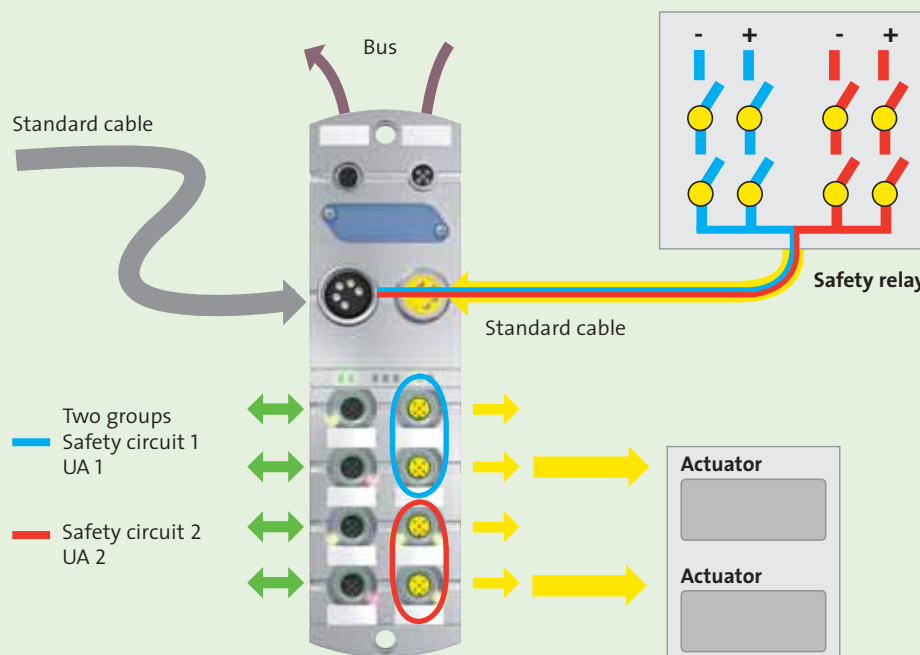

In a two-channel structure, two actuators are connected to two separate MVK Metal groups.

With a single channel safety function, MASI, Cube67, and MVK Metal safety components enable applications to reach Performance Level d, according to EN 13849-1. Even if the safety function is carried out in a redundant or diverse (two channel) structure, Murrelektronik has solutions so the application can reach the performance requirements of Performance Level e.

### OVERVIEW OF SAFETY FIELDBUS COMPONENTS

Model	Description	Art.-No.
Cube67 DO16 C Valve K3	Multipol valve connection, 16 safe outputs (4 groups)	56650
Cube67 DO6 DO6 E 6xM12 K3	Expansion module, 6 safe outputs (2 groups)	56605
MVK-MP-Safety	Profibus-DP, 8 multifunctional I/Os, 8 safe outputs (2 groups)	55291
MASI20 DI4/0.2A DO4/0.5A AB K3	AS-Interface, 4 digital inputs, 4 safe outputs (1 group)	56440
MASI67 DI4/0.2A DO4/1.6A AB K3	AS-Interface, 4 digital inputs, 4 safe outputs (2 groups)	56414
MASI67 DI8/0.34A DO8/1.6A AB K3	AS-Interface, 8 digital inputs, 8 safe outputs (2 groups)	56415
MASI68 DI4/0.2A DO4/1.6A AB Y K3	AS-Interface, 4 digital inputs, 4 safe outputs (1 group)	56423
MASI68 DI4/0.2A DO4/1.6A AB E Y K3	AS-Interface, 4 digital inputs, 4 safe outputs (1 group)	56428