

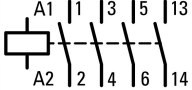

**Contactor, 24 V 50/60 Hz, 3 pole, 380 V 400 V, 4 kW, Contacts N/O = Normally open= 1 N/O, Screw terminals, AC operation**

**Typ** DILEM-10(24V50/60HZ)  
**Catalog No.** 021417  
**Alternate Catalog No.** XTMC9A10T

**Delivery program**

Product range			Contactors
Application			Mini Contactors for Motors and Resistive Loads
Subrange			DILEM contactors
Utilization category			AC-1: Non-inductive or slightly inductive loads, resistance furnaces NAC-3: Normal AC induction motors: starting, switch off during running AC-4: Normal AC induction motors: starting, plugging, reversing, inching
Notes			 Also suitable for motors with efficiency class IE3. IE3-ready devices are identified by the logo on their packaging.
Connection technique			Screw terminals
Description			With auxiliary contact
Number of poles			3 pole
<b>Rated operational current</b>			
AC-3			
380 V 400 V	$I_e$	A	9
AC-1			
Conventional free air thermal current, 3 pole, 50 - 60 Hz			
Open			
at 40 °C	$I_{th} = I_e$	A	22
<b>Max. rating for three-phase motors, 50 - 60 Hz</b>			
AC-3			
220 V 230 V	P	kW	2.2
380 V 400 V	P	kW	4
660 V 690 V	P	kW	4
AC-4			
220 V 230 V	P	kW	1.5
380 V 400 V	P	kW	3
660 V 690 V	P	kW	3
<b>Contacts</b>			
N/O = Normally open			1 N/O
Contact sequence			
For use with			...DILEM ...DILE
Actuating voltage			24 V 50/60 Hz
Voltage AC/DC			AC operation

**Technical data**

<b>General</b>			
Standards			IEC/EN 60947, VDE 0660, CSA, UL
Lifespan, mechanical; Coil 50/60 Hz	Operations	$\times 10^6$	7
Lifespan, mechanical	Operations	$\times 10^6$	10
Maximum operating frequency			

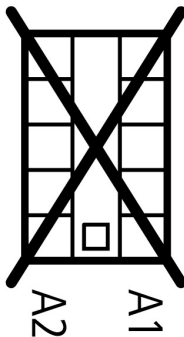
Mechanical	Ops/h	9000
electrical (Contactors without overload relay)	Operations/h	Page 05/070
Climatic proofing		Damp heat, constant, to IEC 60068-2-78 Damp heat, cyclic, to IEC 60068-2-30
Ambient temperature		
Open	°C	-25 - +50
Enclosed	°C	-25 - 40
Storage	°C	
Min. ambient temperature, storage	°C	-40
Ambient temperature, storage max.	°C	+80
Mounting position		As required, except vertical with terminals A1/A2 at the bottom
Mounting position		
Mechanical shock resistance (IEC/EN 60068-2-27)		
Half-sinusoidal shock, 10 ms		
Basic unit without auxiliary contact module		
Main contacts, make contacts	g	10
Main contacts Make/break contacts	g	
Make	g	8
Basic unit with auxiliary contact module		
Main contacts make contact	g	
Make	g	10
Auxiliary contacts Make/break contacts	g	20 / 20
Degree of Protection		IP20
Protection against direct contact when actuated from front (EN 50274)		Finger and back-of-hand proof
Weight	kg	0.17
Terminal capacity of auxiliary and main contacts		
Screw terminals		
Solid	mm <sup>2</sup>	1 x (0.75 - 2.5) 2 x (0.75 - 2.5)
Flexible with ferrule	mm <sup>2</sup>	1 x (0.75 - 1.5) 2 x (0.75 - 1.5)
Solid or stranded	AWG	18 - 14
Stripping length	mm	8
Terminal screw		M3.5
Pozidriv screwdriver	Size	2
Standard screwdriver	mm	0.8 x 5.5 1 x 6
Max. tightening torque	Nm	1.2
<b>Main conducting paths</b>		
Rated impulse withstand voltage	U <sub>imp</sub>	V AC 6000
Overvoltage category/pollution degree		III/3
Rated insulation voltage	U <sub>i</sub>	V AC 690
Rated operational voltage	U <sub>e</sub>	V AC 690
Safe isolation to EN 61140		
between coil and contacts	V AC	300
between the contacts	V AC	300
Making capacity (cos φ to IEC/EN 60947)	A	110
Breaking capacity		

220 V 230 V		A	90
380 V 400 V		A	90
500 V		A	64
660 V 690 V		A	42
Short-circuit protection maximum fuse			
Type "2", 500 V	gL/gG	A	10
Type "1", 500 V	gL/gG	A	20

## AC

AC-1			
Rated operational current			
Conventional free air thermal current, 3 pole, 50 - 60 Hz			
Open			
at 40 °C	$I_{th} = I_e$	A	22
at 50 °C	$I_{th} = I_e$	A	20
at 55 °C	$I_{th} = I_e$	A	19
enclosed	$I_{th}$	A	16
Notes			At maximum permissible ambient air temperature.
Conventional free air thermal current, 1 pole			
Notes			At maximum permissible ambient air temperature.
open	$I_{th}$	A	50
enclosed	$I_{th}$	A	40
AC-3			
Rated operational current			
Open, 3-pole: 50 – 60 Hz			
Notes			At maximum permissible ambient temperature (open.)
220 V 230 V	$I_e$	A	9
240 V	$I_e$	A	9
380 V 400 V	$I_e$	A	9
415 V	$I_e$	A	9
440V	$I_e$	A	9
500 V	$I_e$	A	6.4
660 V 690 V	$I_e$	A	4.8
Motor rating	P	kWh	
220 V 230 V	P	kW	2.2
240V	P	kW	2.5
380 V 400 V	P	kW	4
415 V	P	kW	4.3
440 V	P	kW	4.6
500 V	P	kW	4
660 V 690 V	P	kW	4
AC-4			
Rated operational current			
Open, 3-pole: 50 – 60 Hz			
Notes			At maximum permissible ambient air temperature.
220 V 230 V	$I_e$	A	6.6
240 V	$I_e$	A	6.6
380 V 400 V	$I_e$	A	6.6
415 V	$I_e$	A	6.6
440 V	$I_e$	A	6.6
500 V	$I_e$	A	5
660 V 690 V	$I_e$	A	3.4
Motor rating	P	kWh	
220 V 230 V	P	kW	1.5
240 V	P	kW	1.8

380 V 400 V	P	kW	3
415 V	P	kW	3.1
440 V	P	kW	3.3
500 V	P	kW	3
660 V 690 V	P	kW	3

## DC

Rated operational current open			
DC-1			
12 V	$I_e$	A	20
24 V	$I_e$	A	20
60 V	$I_e$	A	20
110 V	$I_e$	A	20
220 V	$I_e$	A	20
Current heat losses (3- or 4-pole)			
at $I_{th}$ , 50 °C		W	5.9
at $I_e$ to AC-3/400 V		W	1.2

## Magnet systems

Voltage tolerance			
AC operated			
Dual-frequency coil 50/60 Hz	Pick-up	$x U_c$	0.85 - 1.1
Power consumption			
AC operation			
Dual-frequency coil 50/60 Hz at 50 Hz	Pick-up	VA	30
Dual-frequency coil 50/60 Hz at 50 Hz	Pick-up	W	26
Dual-frequency coil 50/60 Hz at 50 Hz	Sealing	VA	5.4
Dual-frequency coil 50/60 Hz at 50 Hz	Sealing	W	1.8
Dual-frequency coil 50/60 Hz at 60 Hz	Pick-up	VA	29
Dual-frequency coil 50/60 Hz at 60 Hz	Pick-up	W	24
Dual-frequency coil 50/60 Hz at 60 Hz	Sealing	VA	3.9
Dual-frequency coil 50/60 Hz at 60 Hz	Sealing	W	1.8
Duty factor		% DF	100
Switching times at 100 % $U_c$			
Make contact		ms	
Closing delay		ms	
Closing delay min.		ms	14
Closing delay max.		ms	21
Opening delay		ms	
Opening delay min.		ms	8
Opening delay max.		ms	18
Closing delay with top mounting auxiliary contact		ms	45
Reversing contactors			
Changeover time at 110 % $U_c$			
Changeover time min.		ms	16
Changeover time max.		ms	21
Arcing time at 690 V AC		ms	12

## Auxiliary contacts

Positive operating contacts to EN 60947-5-1 appendix L, including auxiliary contact module			Yes
Rated impulse withstand voltage	$U_{imp}$	V AC	6000
Overvoltage category/pollution degree			III/3
Rated insulation voltage	$U_i$	V AC	690
Rated operational voltage	$U_e$	V AC	600
Safe isolation to EN 61140			
between coil and auxiliary contacts		V AC	300
between the auxiliary contacts		V AC	300

Rated operational current				
AC-15				
220 V 240 V	$I_e$	A		6
380 V 415 V	$I_e$	A		3
500 V	$I_e$	A		1.5
DC L/R $\leq$ 15 ms				
Contacts in series:			A	
1	24 V	A		2.5
2	60 V	A		2.5
3	100 V	A		1.5
3	220 V	A		0.5
Conv. thermal current				
	$I_{th}$	A		10
Control circuit reliability				
	Failure rate	$\lambda$		$<10^{-8}$ , < one failure at 100 million operations (at $U_e = 24$ V DC, $U_{min} = 17$ V, $I_{min} = 5.4$ mA)
Component lifespan at $U_e = 240$ V				
AC-15	Operations	$\times 10^6$		0.2
DC current				
L/R = 50 ms: 2 contacts in series at $I_e = 0.5$ A	Operations	$\times 10^6$		0.15
Notes				Switch-on and switch-off conditions based on DC-13, time constant as specified
Short-circuit rating without welding				
Maximum overcurrent protective device				
Short-circuit protection only				PKZM0-4
Short-circuit protection maximum fuse				
500 V		A gG/gL		6
500 V		A fast		10
Current heat loss at a load of $I_{th}$ per contact				
		W		1.1

### Rating data for approved types

Switching capacity				
Maximum motor rating				
Three-phase				
200 V 208 V		HP		2
230 V 240 V		HP		3
460 V 480 V		HP		5
575 V 600 V		HP		5
Single-phase				
115 V 120 V		HP		0.5
230 V 240 V		HP		1.5
General use				A
				15
Auxiliary contacts				
Pilot Duty				
AC operated				A600
DC operated				P300
General Use				
AC				V
				600
AC				A
				10
DC				V
				250
DC				A
				0.5
Short Circuit Current Rating				
Basic Rating				
SCCR				kA
				5
max. Fuse				A
				45

## Design verification as per IEC/EN 61439

Dane techniczne dla zaświadczenia rodzaju konstrukcji			
Znamionowy prąd pracy do podania straty mocy	$I_n$	A	9
Strata mocy na biegun, w zależności od prądu	$P_{vid}$	W	0.4
Strata mocy elementu eksploatacyjnego, w zależności od prądu	$P_{vid}$	W	1.2
Strata mocy statyczna, niezależnie od prądu	$P_{vs}$	W	1.8
Zdolność oddawania straty mocy	$P_{ve}$	W	0
Robocza temperatura otoczenia min.		°C	-25
Robocza temperatura otoczenia maks.		°C	50
Certyfikat konstrukcji IEC/EN 61439			
10.2 Wytrzymałość materiałów i części			
10.2.2 Odporność na korozję			Wymagania odnośnie normy produktowej zostały spełnione.
10.2.3.1 Wytrzymałość cieplna powłoki			Wymagania odnośnie normy produktowej zostały spełnione.
10.2.3.2 Rezystancja materiału izolacyjnego przy normalnym cieple			Wymagania odnośnie normy produktowej zostały spełnione.
10.2.3.3 Rezystancja materiału izolacyjnego przy nietypowym cieple			Wymagania odnośnie normy produktowej zostały spełnione.
10.2.4 Wytrzymałość na działanie promieniowania UV			Wymagania odnośnie normy produktowej zostały spełnione.
10.2.5 Podnoszenie			Nie dotyczy, ponieważ należy ocenić całą szafę sterowniczą.
10.2.6 Kontrola odporności na uderzenia			Nie dotyczy, ponieważ należy ocenić całą szafę sterowniczą.
10.2.7 Napisy			Wymagania odnośnie normy produktowej zostały spełnione.
10.3 Stopień ochrony powłok			Nie dotyczy, ponieważ należy ocenić całą szafę sterowniczą.
10.4 Odstępy izolacyjne powietrzne i prądów pełzających			Wymagania odnośnie normy produktowej zostały spełnione.
10.5 Ochrona przed porażeniem elektrycznym			Nie dotyczy, ponieważ należy ocenić całą szafę sterowniczą.
10.6 Montaż elementów eksploatacyjnych			Nie dotyczy, ponieważ należy ocenić całą szafę sterowniczą.
10.7 Wewnętrzne obwody prądowe i połączenia			Należy do zakresu odpowiedzialności wykonawcy szafy sterowniczej.
10.8 Przyłącza przewodów wchodzących z zewnątrz			Należy do zakresu odpowiedzialności wykonawcy szafy sterowniczej.
10.9 Właściwości izolacji			
10.9.2 Wytrzymałość elektryczna o częstotliwości roboczej			Należy do zakresu odpowiedzialności wykonawcy szafy sterowniczej.
10.9.3 Odporność na napięcie udarowe			Należy do zakresu odpowiedzialności wykonawcy szafy sterowniczej.
10.9.4 Sprawdzanie powłok z materiału izolacyjnego			Należy do zakresu odpowiedzialności wykonawcy szafy sterowniczej.
10.10 Nagrzanie			Oszacowanie nagrzania należy do zakresu odpowiedzialności wykonawcy szafy sterowniczej. Eator dostarczy danych na temat straty mocy aparatów.
10.11 Odporność na zwarcia			Należy do zakresu odpowiedzialności wykonawcy szafy sterowniczej. Przestrzegać wytycznych odnośnie aparatów łączeniowych.
10.12 Kompatybilność elektromagnetyczna			Należy do zakresu odpowiedzialności wykonawcy szafy sterowniczej. Przestrzegać wytycznych odnośnie aparatów łączeniowych.
10.13 Działanie mechaniczne			Spełnienie wymagań w aparacie jest jednoznaczne z przestrzeganiem instrukcji montażu (IL).

## Technical data ETIM 7.0

Urządzenia niskonapięciowe (EG000017) / Stycznik AC (EC000066)			
Elektrotechnika, automatyzacja i technologia / Rozdzielnice niskonapięciowe / Stycznik (niskie napięcia) / Stycznik mocy (ecl@ss10.0.1-27-37-10-03 [AAB718015])			
Znamionowe napięcie sterowania $U_s$ dla AC 50 Hz	V		24 - 24
Znamionowe napięcie sterowania $U_s$ dla AC 60 Hz	V		24 - 24
Znamionowe napięcie sterowania $U_s$ dla DC	V		0 - 0
Rodzaj napięcia sterowania			AC
Znamionowy prąd pracy $I_e$ dla AC-1, 400 V	A		22
Znamionowy prąd pracy $I_e$ dla AC-3, 400 V	A		9
Znamionowa moc pracy dla AC-3, 400 V	kW		4
Znamionowy prąd pracy dla AC-4, 400 V	A		6.6
Znamionowa moc pracy dla AC-4, 400 V	kW		3
Znamionowa moc pracy NEMA	kW		3.7
Wersja modułowa			Nie
Liczba styków pomocniczych zwiernych			1
Liczba styków pomocniczych rozwiernych			0
Rodzaj podłączenia styków głównych			Połączenie śrubowe
Liczba styków głównych rozwiernych			0

## Approvals

Product Standards	IEC/EN 60947-4-1; UL 508; CSA-C22.2 No. 14-05; CE marking
UL File No.	E29096
UL Category Control No.	NLDX
CSA File No.	012528
CSA Class No.	3211-04
North America Certification	UL listed, CSA certified
Specially designed for North America	No

## Characteristics

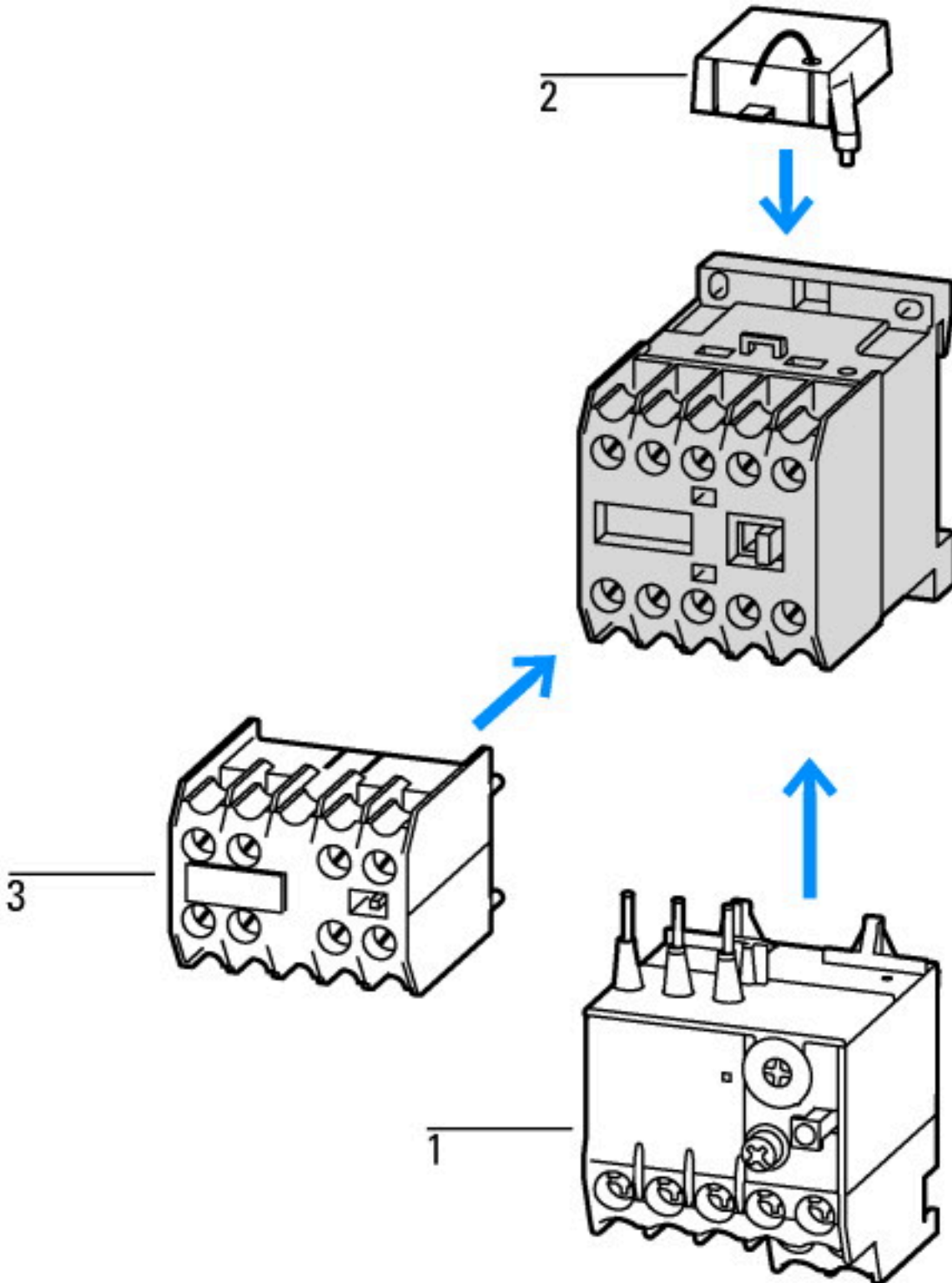

- 1: Overload relay
- 2: Suppressor
- 3: Auxiliary contact modules



- Squirrel-cage motor
- Operating characteristics
- Starting: from rest
- Stopping: after attaining full running speed
- Electrical characteristics
- Make: up to 6 x rated motor current
- Break: up to 1 x rated motor current
- Utilization category
- 100 % AC-3
- Typical applications
- Compressors
- Lifts
- Mixers
- Pumps
- Escalators
- Agitators
- Fans
- Conveyor belts
- Centrifuges
- Hinged flaps
- Bucket-elevators
- Air conditioning system
- General drives in manufacturing and processing machines





- Extreme switching duty
- Squirrel-cage motor
- Operating characteristics
- Inching, plugging, reversing
- Electrical characteristics
- Make: up to 6 x rated motor current
- Break: up to 6 x rated motor current
- Utilization category
- 100 % AC-4
- Typical applications
- Printing presses
- Wire-drawing machines
- Centrifuges
- Special drives for manufacturing and processing machines



Switching duty for non-motor loads, 3-pole, 4-pole  
 Operating characteristics  
 Non-inductive or slightly inductive loads  
 Electrical characteristics  
 Make: 1 x rated current  
 Break: 1 x rated current  
 Utilization category  
 100 % AC-1  
 Typical applications  
 Electric heat



Short-time loading, 3-pole  
 Time interval between two loading cycles: 15 minutes

### Dimensions

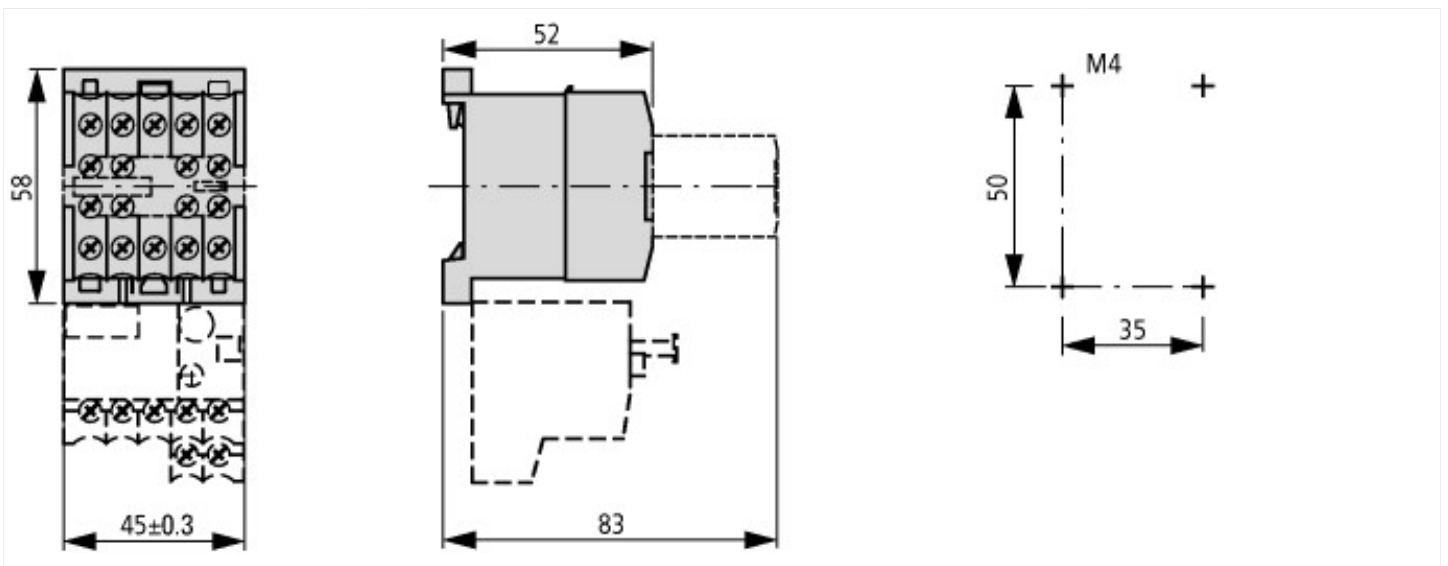



2DILE-... + MVDILE + ...DILE  
2DILE-...-G + MVDILE + ...DILE

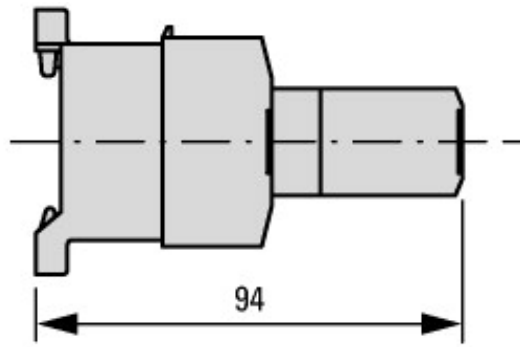
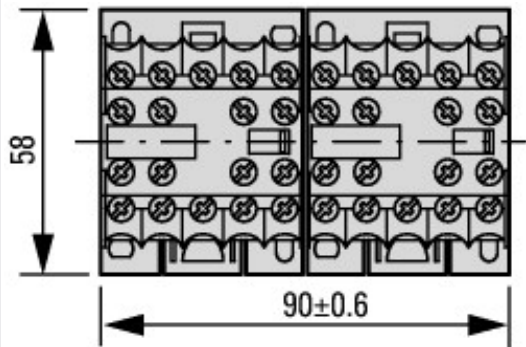

2DILE-... + MVDILE + ...DILE  
2DILE-...-G + MVDILE + ...DILE



2DILE-... + MVDILE  
2DILE-...-G + MVDILE

## Assets (links)

### Declaration of CE Conformity

00003110

### Instruction Leaflets

IL03407009Z2018\_04

## Additional product information (links)

IL03407009Z (AWA2100-0882) Mały stycznik

IL03407009Z (AWA2100-0882) Mały stycznik [ftp://ftp.moeller.net/DOCUMENTATION/AWA\\_INSTRUCTIONS/IL03407009Z2018\\_04.pdf](ftp://ftp.moeller.net/DOCUMENTATION/AWA_INSTRUCTIONS/IL03407009Z2018_04.pdf)