

Contents	Page
Summary .....	<b>06.5</b>
Han-Modular® hinged frames .....	<b>06.9</b>
Han-Modular® docking frames.....	<b>06.14</b>
Han® PE module.....	<b>06.18</b>
Han® 200 A module.....	<b>06.20</b>
Han® 200 A PE module.....	<b>06.22</b>
Han® 100 A module.....	<b>06.24</b>
Han® 100 A Single module.....	<b>06.26</b>
Han® 70 A module.....	<b>06.28</b>
Han® 70 A Hybrid module .....	<b>06.31</b>
Han® 40 A module.....	<b>06.34</b>
Han® C module .....	<b>06.37</b>
Han® CC Protected module .....	<b>06.39</b>
Han® CD module .....	<b>06.41</b>
Han E® module .....	<b>06.44</b>
Han E® Screw module .....	<b>06.47</b>
Han E® Protected module.....	<b>06.48</b>
Han® EE module.....	<b>06.51</b>
Han® EEE module .....	<b>06.54</b>
Han® ES module.....	<b>06.57</b>
Han® HV module.....	<b>06.59</b>
Han® HV Single module.....	<b>06.62</b>
Han DD® module .....	<b>06.64</b>

Contents	Page
Han DD® Quad Module.....	<b>06.67</b>
Han® DDD module.....	<b>06.69</b>
Han® High Density module .....	<b>06.71</b>
Han® D-Sub module .....	<b>06.73</b>
Han® USB module .....	<b>06.76</b>
Han® FireWire module .....	<b>06.78</b>
Han® RJ45 module, female .....	<b>06.79</b>
Han® RJ45 module, male .....	<b>06.81</b>
RJ45 patch cable.....	<b>06.85</b>
Han® Gigabit module .....	<b>06.87</b>
Han® Shielded module.....	<b>06.89</b>
Han® Megabit module.....	<b>06.91</b>
Accessories for Gigabit, Shielded and Megabit.....	<b>06.96</b>
Han-Quintax® module .....	<b>06.98</b>
Han-Quintax® High Density module.....	<b>06.100</b>
Han® D Coax .....	<b>06.102</b>
Han® E Coax.....	<b>06.104</b>
Han® Multi module .....	<b>06.106</b>
Han® Pneumatic module.....	<b>06.113</b>
Han® SC module.....	<b>06.116</b>
Han® LC module .....	<b>06.119</b>
Han® ID CAN module .....	<b>06.121</b>
smart Han® .....	<b>06.122</b>

Contents	Page
Han-Modular® Compact.....	<b>06.123</b>
Han-Modular® Twin.....	<b>06.127</b>
Han-Modular® ECO .....	<b>06.130</b>
Accessories .....	<b>06.135</b>

## Description of the Han-Modular® system

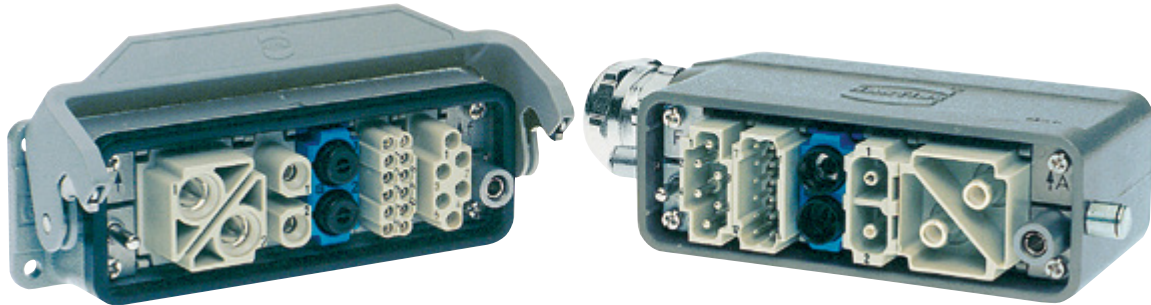

### Assembly details



The Han-Modular® series is designed for combining different transmission media in one connector. The multifaceted system of inserts, contacts, frames, hoods and housings fulfils individual customer requirements. To continuously enable new configurations, the Han-Modular® series grows constantly.

More than 50 different modules for different transmission media are available. These cover various termination techniques. The patented Han-Modular® hinged frame enables the configuration of all modules in the well-accepted Han® hoods and housings size 6B-48B. Further additional solutions are available, e.g. suitable docking frames for drawer units.

Individual customer requirements can be realized. Combining various transmission media in one single connector results in lower expenditures in installation time and production downtime. Space savings and cost savings are further benefits. The easy extension possibilities secure a future safe design.

### Product features at a glance

- Flexible solutions according to specific customer requirements
- Reduction of installation time and production downtimes
- Space savings
- Cost savings
- Future safe design, easy extension

	Han® 200 A Axial Module	Han® 200 A PE Module	Han® 100 A Axial Module	Han® PE Module	
100 - 200 A					
	Number of contacts	1*	1*	1 x PE	
	Electrical data	200 A / 1000 V	1 x PE* 200 A	100 A / 1000 V	100 A
	Termination type	Axial screw termination	Axial screw termination	Axial screw termination	Axial screw termination
	Cross-section	40 ... 70 mm <sup>2</sup>	40 ... 70 mm <sup>2</sup>	16 ... 35 mm <sup>2</sup>	16 ... 35 mm <sup>2</sup>
	Male module (M)	09 14 001 2662	09 14 001 2667	09 14 002 2651	09 14 001 2633
Female module (F)	09 14 001 2762	09 14 001 2767	09 14 002 2751	09 14 001 2733	
40 - 70 A					
	Number of contacts	2	1 + (4 x Han E®)	3	
	Electrical data	70 A / 1000 V	70 A / 1000 V	40 A / 1000 V	40 A / 690 V
	Termination type	Axial screw termination	Axial screw termination	Axial screw termination	Axial screw termination
	Cross-section	14 ... 22 mm <sup>2</sup>	14 ... 22 mm <sup>2</sup>	6 ... 10 mm <sup>2</sup>	6 ... 10 mm <sup>2</sup>
	Male module (M)	09 14 002 2647	09 14 005 2647	09 14 002 2602	09 14 003 2602
Female module (F)	09 14 002 2742	09 14 005 2742	09 14 002 2702	09 14 003 2702	
16 A					
	Number of contacts	6	8	5	5
	Electrical data	16 A / 500 V	16 A / 400 V	16 A / 400 V	16 A / 230/400 V
	Termination type	Quick Lock termination	Quick Lock termination	Cage clamp termination	Screw termination
	Cross-section	0.5 ... 2.5 mm <sup>2</sup>	0.5 ... 2.5 mm <sup>2</sup>	0.14 ... 2.5 mm <sup>2</sup>	0.5 ... 2.5 mm <sup>2</sup>
	Male module (M)	09 14 006 2633	09 14 008 2633	09 14 005 2616	09 14 005 2601
Female module (F)	09 14 006 2733	09 14 008 2733	09 14 005 2716	09 14 005 2701	
≤ 10 A					
	Number of contacts	12, silver plated	12, gold plated		
	Electrical data	10 A / 250 V	10 A / 250 V		
	Termination type	Quick Lock termination	Quick Lock termination		
Cross-section	0.25 ... 1.5 mm <sup>2</sup>	0.25 ... 1.5 mm <sup>2</sup>			
Male module (M)	09 14 012 2632	09 14 012 2634			
Female module (F)	09 14 012 2732	09 14 012 2734			
Axial screw termination	Hexagonal drivers	with grip	Bit 1/4"	Adapter 3/8"	Hexagonal torque set
	2 mm ( 40 A)	09 99 000 0313	09 99 000 0369		09 99 000 0834
	2.5 mm ( 70 A)		09 99 000 0375		09 99 000 0834
	4 mm (100 A)	09 99 000 0363		09 99 000 0370	09 99 000 0833
5 mm (200 A)	09 99 000 0364		09 99 000 0371	09 99 000 0833	

Modular

\* Double module, requires two places in the frame

# Summary



Modu-  
lar

		Han® PE module (Including crimp contact for earthing)				
PE	Number of contacts	1 x PE	1 x PE	1 x PE		
	Cross-section	35 mm <sup>2</sup>	25 mm <sup>2</sup>	16 mm <sup>2</sup>		
	Termination type	Crimp termination, Han® HC	Crimp termination, Han® HC	Crimp termination, Han® HC		
	Male module (M)	09 14 001 3074	09 14 001 3073	09 14 001 3072		
	Female module (F)	09 14 001 3174	09 14 001 3173	09 14 001 3172		
70 - 200 A		Han® 200 A Crimp module	Han® 100 A Crimp module	Han® 100 A Single module	Han® 70 A Crimp module	
	Number of contacts	1*	2*	1	2	
	Electrical data	200 A / 1000 V	100 A / 1000 V	100 A / 830 V	70 A / 1000 V	
	Cross-section	25 ... 70 mm <sup>2</sup>	10 ... 35 mm <sup>2</sup>	10 ... 35 mm <sup>2</sup>	6 ... 25 mm <sup>2</sup>	
	Termination type	Crimp termination, Han® HC	Crimp termination, Han® HC	Crimp termination, Han® HC	Crimp termination, Han® HC	
	Male module (M)	09 14 001 3001	09 14 002 3051	09 14 001 3031	09 14 002 3041	
	Female module (F)	09 14 001 3101	09 14 002 3151	09 14 001 3131	09 14 002 3141	
40 A		Han® 40 A Crimp module	Han® C module	Han® CC module	Han® CD module	
	Number of contacts	2	3	4	3 + 4	
	Electrical data	40 A / 1000 V	40 A / 690 V	40 A / 830 V	40 A + 10 A / 830 V	
	Cross-section	1.5 ... 10 mm <sup>2</sup>	1.5 ... 6 mm <sup>2</sup>	1.5 ... 6 mm <sup>2</sup>	0.14 ... 6 mm <sup>2</sup>	
	Termination type	Crimp termination, Han® C	Crimp termination, Han® C	Crimp termination, Han® C	Crimp, Han® C + Han D®	
	Male module (M)	09 14 002 3002	09 14 003 3001	09 14 004 3041	09 14 007 3001	
	Female module (F)	09 14 002 3102	09 14 003 3101	09 14 004 3141	09 14 007 3101	
16 A		Han E® module	Han® EE module	Han® EEE module	Han E® Protected module	
	Number of contacts	6	8	20*	6	
	Electrical data	16 A / 500 V	16 A / 400 V	16 A / 500 V	16 A / 830 V	
	Cross-section	0.14 ... 4 mm <sup>2</sup>	0.14 ... 4 mm <sup>2</sup>	0.14 ... 4 mm <sup>2</sup>	0.14 ... 4 mm <sup>2</sup>	
	Termination type	Crimp termination, Han E®	Crimp termination, Han E®	Crimp termination, Han E®	Crimp termination, Han E®	
	Male module (M)	09 14 006 3001	09 14 008 3001	09 14 020 3001	09 14 006 3041	
	Female module (F)	09 14 006 3101	09 14 008 3101	09 14 020 3101	09 14 006 3141	
≤ 10 A		Han DD® module	Han® DDD module	Han DD® Quad module	Han® High Density module	
	Number of contacts	12	17	42*	25	
	Electrical data	10 A / 250 V	10 A / 150 V	10 A / 150 V	4 A / 50 V	
	Cross-section	0.14 ... 2.5 mm <sup>2</sup>	0.14 ... 2.5 mm <sup>2</sup>	0.14 ... 2.5 mm <sup>2</sup>	0.08 ... 0.52 mm <sup>2</sup>	
	Termination type	Crimp termination, Han D®	Crimp termination, Han D®	Crimp termination, Han D®	Crimp termination, D-Sub	
	Male module (M)	09 14 012 3002	09 14 017 3001	09 14 042 3001	09 14 025 3001	
	Female module (F)	09 14 012 3102	09 14 017 3101	09 14 042 3101	09 14 025 3101	
High Voltage		Han® HV module 40 A	Han® HV module 16 A	Han® HV single module		
	Number of contacts	2*	2*	2		
	Electrical data	40 A / 2900/5000 V	16 A / 2900/5000 V	16 A / 2500 V		
	Cross-section	1.5 ... 10 mm <sup>2</sup>	0.14 ... 4 mm <sup>2</sup>	0.14 ... 4 mm <sup>2</sup>		
	Termination type	Crimp termination, Han® C	Crimp termination, Han E®	Crimp termination, Han E®		
	Male module (M)	09 14 002 3023	09 14 002 3021	09 14 002 3025		
	Female module (F)	09 14 002 3123	09 14 002 3121	09 14 002 3125		

\* Double module, requires two places in the frame

# Summary



	Han® RJ45 module	for patch cable	for IDC	for patch cable	for IDC and preLink
Han® RJ45 module	- 8 contacts - cat. 6A - 10 Gbit/s				
	Part numbers	Male module (M) 09 14 001 4623	Male module (M) 09 14 001 4623	Female module (F) 09 14 001 4721	Female module (F) 09 14 001 4722
		Adapter for patch cable: 09 14 000 9966	RJ Industrial IDC: 09 45 400 1560		RJ45 female IDC: 09 14 545 1561
		Patch cable cat. 6: 09 47 474 71xx			RJ45 female preLink: 09 14 008 4720
	Han-Quintax®	Han® High Density Quintax	Han D® Coax	Han E® Coax	
Han-Quintax® Modules	Quintax modul				
	Number of contacts	2 x 4*	2 x 8*	2 x Coax*	2 x Coax*
	Male module (M)	09 14 002 3001	09 14 002 3001	09 14 002 3001	09 14 002 3001
	Female module (F)	09 14 002 3101	09 14 002 3101	09 14 002 3101	09 14 002 3101
	Insert (Cable Ø ≤ 9.5 mm)				
	Data rate	100 Mbit/s (cat. 5e)	100 Mbit/s (cat. 5e)	≤ 500 Mhz / 75 Ω	≤ 500 Mhz / 50 Ω
	Electrical data	10 A / 50 V	5 A / 50 V	10 A / 50 V	16 A / 50 V
	Cross-section	0.14 ... 2.5 mm²	0.09 ... 0.52 mm²	0.14 ... 2.5 mm²	0.14 ... 4 mm²
	Termination type	Crimp termination, Han D®	Crimp termination, D-Sub	Crimp termination, Han D®	Crimp termination, Han E®
	Male insert (M)	09 15 004 3013	09 15 008 3013	09 15 001 3013	09 15 001 3023
Female insert (F)	09 15 004 3113	09 15 008 3113	09 15 001 3113	09 15 001 3123	
PE shielding termination	Optional shielding termination to the hinged frame with the aid of Han-Quintax® metal adapter 09 14 000 9915				
	Han® GigaBit module	Han® MegaBit module with 2 cable entries	Han® MegaBit module with 1 cable entry	Han® Shielded Module	
Han® GigaBit – Han® MegaBit Modules	Adapter Module				
	Male module (M)	09 14 001 3011	09 14 001 3011	09 14 001 3011	09 14 001 3011
	Female module (F)	09 14 001 3111	09 14 001 3111	09 14 001 3111	09 14 001 3111
	Insert (Cable Ø ≤ 14 mm)				
	Number of contacts	8	2 x 4	8	20
	Data rate	10 Gbit/s (cat. 6A)	2 x 100 Mbit/s (cat. 5e)	1 Gbit/s (cat. 5e)	
	Electrical data	5 A / 50 V	10 A / 50 V	10 A / 50 V	4 A / 32 V
	Cross-section	0.09 ... 0.52 mm²	0.14 ... 2.5 mm²	0.14 ... 2.5 mm²	0.09 ... 0.52 mm²
	Termination type	Crimp termination, D-Sub	Crimp termination, Han D®	Crimp termination, Han D®	Crimp termination, D-Sub
	Shielding termination	Crimp flange	2 x crimp flange	Crimp flange	Crimp flange
Male insert (M)	09 14 008 3011	09 14 008 3016	09 14 008 3021	09 14 020 3013	
Female insert (F)	09 14 008 3111	09 14 008 3116	09 14 008 3121	09 14 020 3113	
	with PE shielding termination	with PE shielding termination	with PE shielding termination		
Male insert (M)	09 14 008 3012	09 14 008 3017	09 14 008 3022		
Female insert (F)	09 14 008 3112	09 14 008 3117	09 14 008 3122		
	Han D-Sub module	Han® USB module	Han® FireWire module	Han® ID CAN module	
Serial Bus Modules					
	Number of contacts	9 + shielding	8	6	7
	Data rate	12 Mbit/s (Profibus)	5 Gbit/s (USB 3.0)	400 Mbit/s (IEEE 1394a)	1 Mbit/s (CAN bus)
	Electrical data	5 A / 50 V	1 A / 50 V	1 A / 50 V	24 V
	Cross-section	0.09 ... 0.52 mm²			0.13 ... 1.5 mm²
Termination type	Crimp termination, D-Sub	USB patch cable	FireWire patch cable	Cage clamp termination	
Male module (M)	09 14 009 3001	09 14 001 4601	09 14 001 4611	09 80 015 0100	
Female module (F)	09 14 009 3101	09 14 001 4703	09 14 001 4711	09 80 115 0200	

\* Double module, requires two places in the frame

Modu-  
lar

Modular

		Han® Multi Module (for D-Sub coaxial contacts)		Han® Multi Module (for DIN 41626 coaxial contacts)	
Coaxial Modules					
	Number of contacts	4	4	12*	12*
	Male module (M)	09 14 004 4501	09 14 004 4501	09 14 012 4501	09 14 012 4501
	Female module (F)	09 14 004 4513	09 14 004 4513	09 14 012 4512	09 14 012 4512
	Coaxial contacts (≤ 2 GHz)				
	Impedance	75 Ω	50 Ω	75 Ω	50 Ω
	Coaxial cable	RG179, RG187	RG174, RG188, RG316	RG179, RG187	RG174, RG188, RG316
	Termination type	Crimp /crimp termination	Crimp /crimp termination	Solder /crimp termination	Solder /crimp termination
	Male contact	09 69 282 5230	09 69 282 5140	09 14 000 6221	09 14 000 6211
Female contact	09 69 182 5230	09 69 182 5140	09 14 000 6121	09 14 000 6111	
Optical Modules		Han® LC module	Han® SC module	Han® Multi module	Han® Multi module
	Number of contacts	6	4	4	12*
	Male module (M)	09 14 006 4701	09 14 004 4701	09 14 004 4501	09 14 012 4501
	Female module (F)	09 14 006 4711	09 14 004 4711	09 14 004 4512	09 14 012 4512
	Contacts				
	1 mm POF		20 10 001 5211	Male: 20 10 001 4211 Female: 20 10 001 4221	Male: 20 10 001 4211 Female: 20 10 001 4221
	1 mm POF Fast assembly termination		20 10 001 5217		
	SI-Fibre 200 / 230 µm Multi-Mode		20 10 230 5211	Male: 20 10 230 4211 Female: 20 10 230 4221	Male: 20 10 230 4211 Female: 20 10 230 4221
	GI-Fibre 50-62,5 / 125 µm Multi-Mode	20 10 125 8211	20 10 125 5211	Male: 20 10 125 4212 Female: 20 10 125 4222	Male: 20 10 125 4212 Female: 20 10 125 4222
GI-Fibre 9 / 125 µm Single-Mode	20 10 125 8220	20 10 125 5220			
Pneumatic Modules		Han® Pneumatic module		Han® Pneumatic module	
	Number of contacts	2	3		
	Male module	09 14 002 4501	09 14 003 4501		
	Female module	09 14 002 4501	09 14 003 4501		
	Tube Ø (inner)	6 mm	4 mm	3 mm	1.6 mm
	Contacts - max. 8 bar				
	Male contact	09 14 000 6174	09 14 000 6153	09 14 000 6152	09 14 000 6151
Female without valve seal	09 14 000 6274	09 14 000 6253	09 14 000 6252	09 14 000 6251	
Female with valve seal	09 14 000 6279	09 14 000 6258	09 14 000 6257	09 14 000 6256	
Special Modules		Han-Yellok® Multiplier	Han-Eco® PE module	Han-Eco® Monoblock	Han® Dummy module
	Field of application	for contact bridges	for Han-Eco® hoods/housings only	for Han-Eco® hoods/housings only	to fill-up empty module places
	Number of contacts	3 x 5	1 x PE	10, 14, 20, 28 + PE	
	Electrical data	16 A / 500 V		16 A / 500 V	
	Cross-section	0.14 ... 4 mm²	1.5 ... 16 mm²	0.5 ... 2.5 mm²	
Termination type	Crimp termination, Han E®	Screw termination	Screw termination		
Male module (M)	09 14 015 3001	19 41 001 2600	19 41 0xx 2601	09 14 000 9950	
Female module (F)	09 14 015 3101	19 41 001 2700	19 41 0xx 2701		
* Double module, requires two places in the frame					



## Features

- Suitable for more than 100 different modules
- Quick and easy assembly supported by an audible “Click”
- Very robust mechanical characteristics
- Modules can be assembled/removed without tools
- Two leading PE contacts
- Easy handling

## Technical characteristics

Limiting temperature	-40 ... +125 °C
Mating cycles	≥500
Mating cycles with other HMC components	≥10000
Material (frames)	Zinc die-cast, Stainless steel

## Specifications and approvals

EN 60664-1  
IEC 61984



## Details

Both different markings must be used for one connector!

Conductor cross-section PE (power side) 4 ... 10 mm<sup>2</sup>



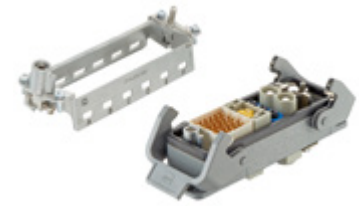

Conductor cross-section 10 mm<sup>2</sup> only with ferrule crimping tool  
09 99 000 0374

Conductor cross-section PE (signal side) 1 ... 2.5 mm<sup>2</sup>

**Locking element** 09 14 000 9960 see accessories in chapter 06

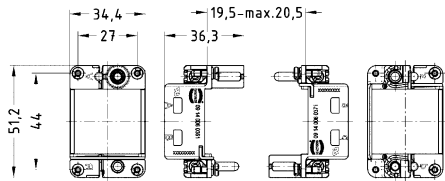

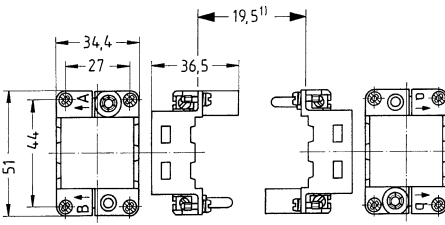
Modular

Identification	Part number	Drawing (dimensions in mm)
<p>Han-Modular®, Hinged frame, for 2 modules, A ... B, Mating cycles ≥500</p> 	<p>09 14 006 0361</p>	
<p>Han-Modular®, Hinged frame, for 2 modules, a ... b, Mating cycles ≥500</p> 	<p>09 14 006 0371</p>	
<p>Han-Modular®, Hinged frame, HMC version, for 2 modules, A ... B, Mating cycles ≥10000</p> 	<p>09 14 206 0303</p>	 <p>1) Distance max. 20.5 mm</p>
<p>Han-Modular®, Hinged frame, HMC version, for 2 modules, a ... b, Mating cycles ≥10000</p> 	<p>09 14 206 0313</p>	

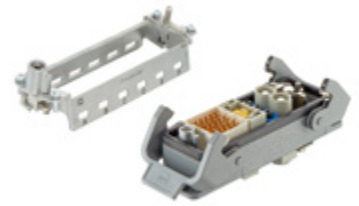

Identification	Part number	Drawing (dimensions in mm)
Han-Modular®, Hinged frame, for 3 modules, A ... C, Mating cycles ≥500	09 14 010 0361	
Han-Modular®, Hinged frame, for 3 modules, a ... c, Mating cycles ≥500	09 14 010 0371	
Han-Modular®, Hinged frame, HMC version, for 3 modules, A ... C, Mating cycles ≥10000	09 14 210 0303	<p>1) Distance max. 20.5 mm</p>
Han-Modular®, Hinged frame, HMC version, for 3 modules, a ... c, Mating cycles ≥10000	09 14 210 0313	

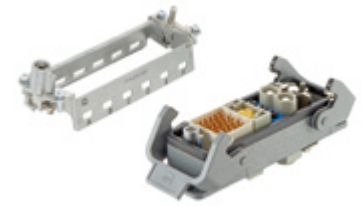

Identification

Part number

Drawing (dimensions in mm)

Modular

Han-Modular®,  
Hinged frame,  
for 4 modules,  
A ... D,  
Mating cycles ≥500

09 14 016 0361

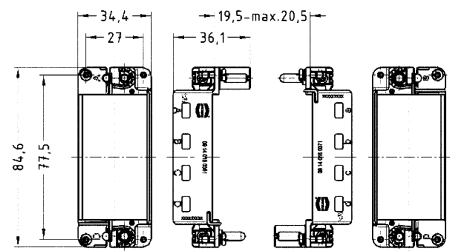
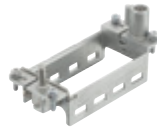

Han-Modular®,  
Hinged frame,  
for 4 modules,  
a ... d,  
Mating cycles ≥500

09 14 016 0371

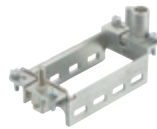

Han-Modular®,  
Hinged frame,  
HMC version,  
for 4 modules,  
A ... D,  
Mating cycles ≥10000

09 14 216 0303

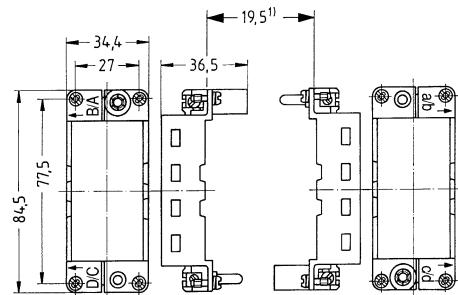





1) Distance max. 20.5 mm

Han-Modular®,  
Hinged frame,  
HMC version,  
for 4 modules,  
a ... d,  
Mating cycles ≥10000

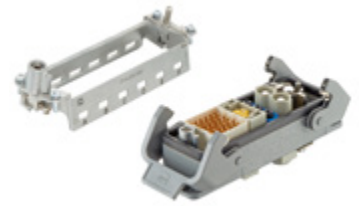
09 14 216 0313

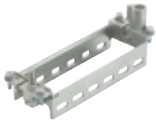
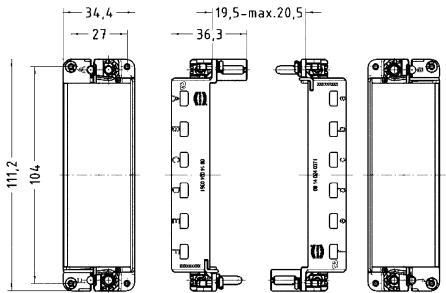
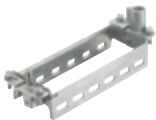
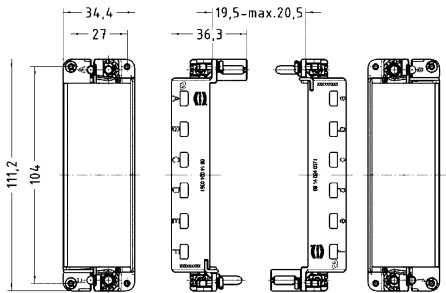

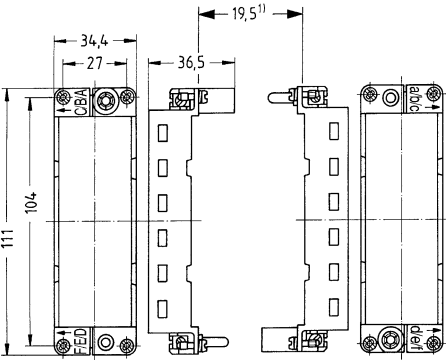

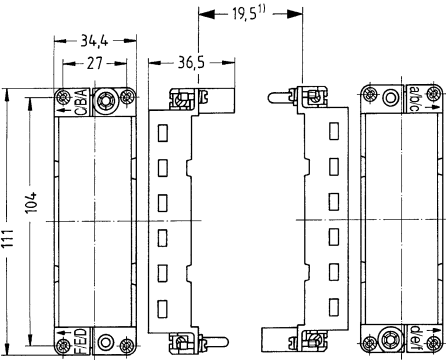
Identification	Part number	Drawing (dimensions in mm)
<p>Han-Modular®, Hinged frame, for 6 modules, A ... F, Mating cycles ≥500</p> 	<p>09 14 024 0361</p>	
<p>Han-Modular®, Hinged frame, for 6 modules, a ... f, Mating cycles ≥500</p> 	<p>09 14 024 0371</p>	
<p>Han-Modular®, Hinged frame, HMC version, for 6 modules, A ... F, Mating cycles ≥10000</p> 	<p>09 14 224 0303</p>	 <p>1) Distance max. 20.5 mm</p>
<p>Han-Modular®, Hinged frame, HMC version, for 6 modules, a ... f, Mating cycles ≥10000</p> 	<p>09 14 224 0313</p>	 <p>1) Distance max. 20.5 mm</p>

## Features

- Blind mating connector system for drawer systems
- Leading centring system compensates for tolerances of +/- 2 mm
- Very robust mechanical characteristics
- Compatible with HMC components for 10,000 mating cycles

## Technical characteristics



Limiting temperature	-40 ... +125 °C
Flammability acc. to UL 94	V-0
Mating cycles	≥500
Mating cycles with other HMC components	≥10000
Degree of protection acc. to IEC 60529	IP20
Lock-in range	±4 mm
Material (frames)	Polycarbonate
Material (accessories)	Zinc die-cast

## Specifications and approvals



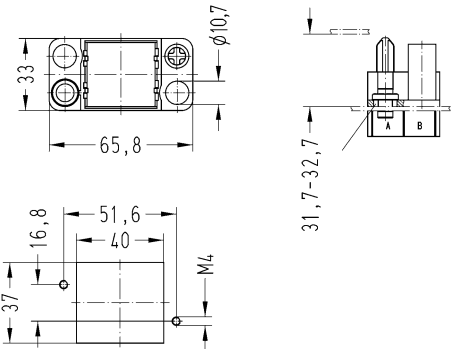

EN 60664-1  
IEC 61984

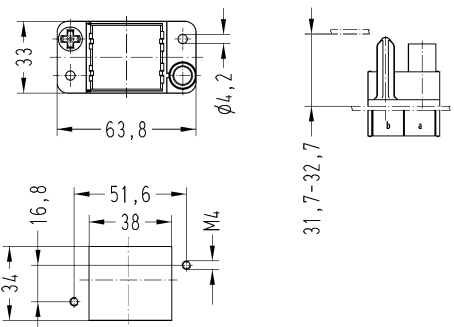
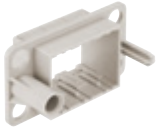
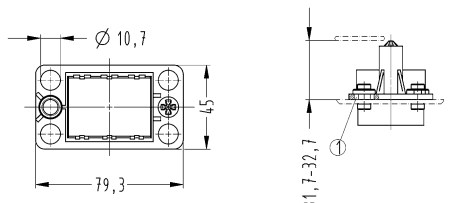
## Details



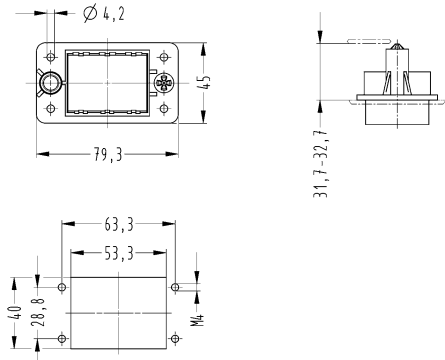

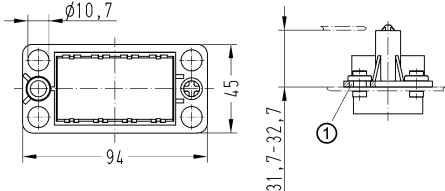
Due the plastic material used in the docking frame without PE, the panel will need to be grounded separately.

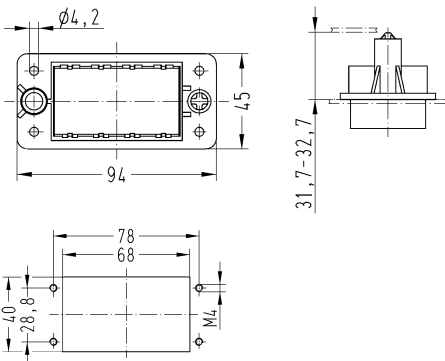
Identification	Part number	Drawing (dimensions in mm)
<p>Han-Modular®, Docking frame, Float mount, for 2 modules, A ... B</p> 	<p>09 14 006 1701</p>	 <p>① Floating tolerance <math>\pm 2</math> mm Panel cut out</p>
<p>Han-Modular®, Docking frame, Fixed, for 2 modules, a ... b</p> 	<p>09 14 006 1711</p>	 <p>Panel cut out</p>
<p>Han-Modular®, Docking frame, Float mount, for 3 modules, A ... C</p> 	<p>09 14 010 1701</p>	 <p>① Floating tolerance <math>\pm 2</math> mm</p>

Modular

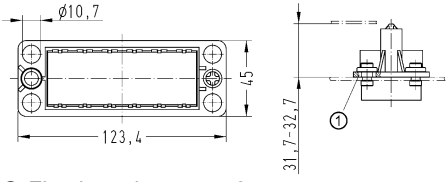
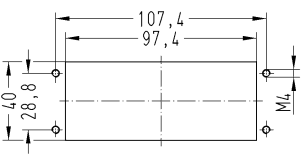
Identification	Part number	Drawing (dimensions in mm)
<p>Han-Modular®, Docking frame, Fixed, for 3 modules, a ... c</p> 	<p>09 14 010 1711</p>	 <p>Panel cut out</p>
<p>Han-Modular®, Docking frame, Float mount, for 4 modules, A ... D</p> 	<p>09 14 016 1701</p>	 <p>① Floating tolerance <math>\pm 2</math> mm</p> <p>Panel cut out</p>
<p>Han-Modular®, Docking frame, Fixed, for 4 modules, a ... d</p> 	<p>09 14 016 1711</p>	 <p>Panel cut out</p>

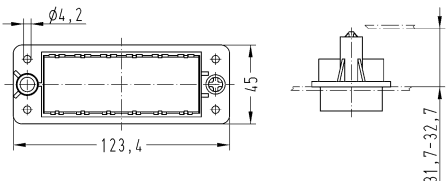
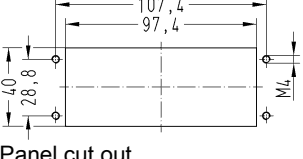

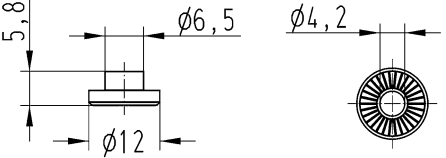
Identification	Part number	Drawing (dimensions in mm)
<p>Han-Modular®, Docking frame, Float mount, for 6 modules, A ... F</p> 	<p>09 14 024 1701</p>	 <p>① Floating tolerance <math>\pm 2</math> mm</p>  <p>Panel cut out</p>
<p>Han-Modular®, Docking frame, Fixed, for 6 modules, a ... f</p> 	<p>09 14 024 1711</p>	  <p>Panel cut out</p>
<p>Han-Modular®, Float washer</p>  <p>To enable the frame to be float mounted using standard M4 fixing screws</p>	<p>09 14 000 9936</p>	

Modular

## Technical characteristics

Contact resistance	≥0.3 mΩ
Limiting temperature	-40 ... +125 °C
Mating cycles	≥500
Material (insert)	Zinc die-cast, nickel-plated
Material (contacts)	Copper alloy

## Specifications and approvals

UL 1977 ECBT2.E235076

Identification	Conductor cross-section (mm <sup>2</sup> )	Part number		Drawing (dimensions in mm)										
		Male	Female											
Han-Modular®, Han® PE module, Crimp termination, Pack contents: 2 PE module halves, 1 contact pressure plate, 1 crimp contact Contact surface: Silver plated	16	09 14 001 3072	09 14 001 3172											
	25	09 14 001 3073	09 14 001 3173											
	35	09 14 001 3074	09 14 001 3174											
				<table border="1"> <caption>Stripping length</caption> <tr> <td>mm<sup>2</sup></td> <td>10</td> <td>16</td> <td>25</td> <td>35</td> </tr> <tr> <td>mm</td> <td>19</td> <td>19</td> <td>19</td> <td>16</td> </tr> </table>	mm <sup>2</sup>	10	16	25	35	mm	19	19	19	16
mm <sup>2</sup>	10	16	25	35										
mm	19	19	19	16										

## Technical characteristics

Contact resistance	≥0.3 mΩ
Limiting temperature	-40 ... +125 °C
Mating cycles	≥500
Material (insert)	Zinc die-cast, nickel-plated
Material (contacts)	Copper alloy

## Specifications and approvals

UL 1977 ECBT2.E235076

## Details

### Remarks on the axial screw technique

The wire gauges mentioned in the catalogue refer to geometric wire gauges of cables.

Modu-  
lar

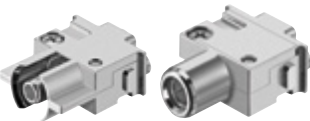
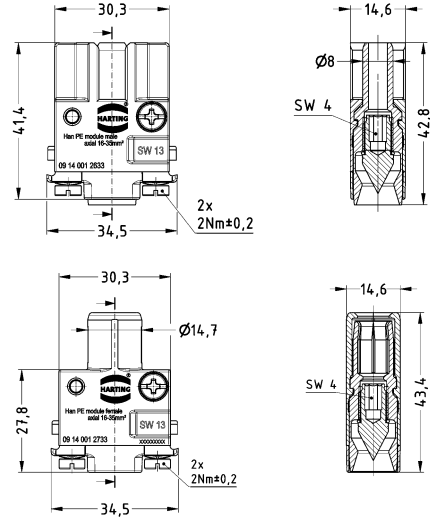
Identification	Conductor cross-section (mm <sup>2</sup> )	Part number		Drawing (dimensions in mm)										
		Male	Female											
Han-Modular®, Han® PE module, Axial screw termination, Pack contents: PE module with pre-assembled axial screw contact Contact surface: Silver plated 	10 ... 25 16 ... 35 22 ... 38	09 14 001 2632 09 14 001 2633 09 14 001 2634	09 14 001 2732 09 14 001 2733 09 14 001 2734	 <p>Stripping length 13 mm</p> <p>Tightening torque</p> <table border="1"> <tr> <td>mm<sup>2</sup></td> <td>10</td> <td>16</td> <td>25</td> <td>35</td> </tr> <tr> <td>Nm</td> <td>6</td> <td>6</td> <td>7</td> <td>8</td> </tr> </table>	mm <sup>2</sup>	10	16	25	35	Nm	6	6	7	8
mm <sup>2</sup>	10	16	25	35										
Nm	6	6	7	8										

## Features

- Crimp- and axial module are compatible modules
- Contacts can be unlocked from the mating side
- Power module for big cross-sections up to 70 mm<sup>2</sup>
- Suitable as a 3 + PE connector in a Han® 32 B housing

## Technical characteristics

Number of contacts	1
Electrical data acc. to IEC 61984	200 A 1.000 V 8 kV 3
Rated current	200 A
Rated voltage	1000 V
Rated impulse voltage	8 kV
Pollution degree	3
Rated voltage acc. to UL	600 V
Insulation resistance	≥10 <sup>10</sup> Ω
Contact resistance	≤0.2 mΩ, ≤0.3 mΩ
Limiting temperature	-40 ... +125 °C
Flammability acc. to UL 94	V-0
Mating cycles	≥500
Material (insert)	Polycarbonate
Colour (insert)	RAL 7032 (pebble grey)
Material (contacts)	Copper alloy

Modular

## Derating

### Current carrying capacity

The current carrying capacity of the connectors is limited by the thermal load capability of the contact element material including the connections and the insulating parts. The derating curve is therefore valid for currents which flow constantly (non-intermittent) through each contact element of the connector evenly, without exceeding the allowed maximum temperature.

Measuring and testing techniques acc. to IEC 60512-5-2

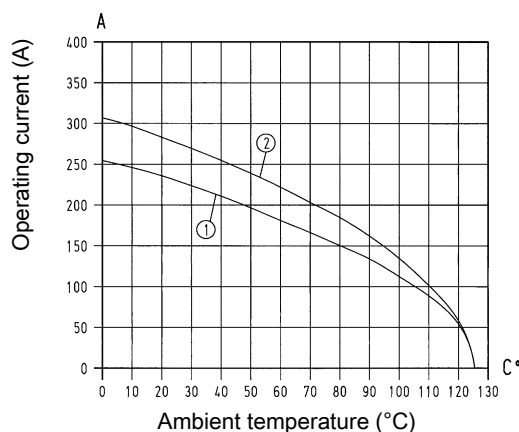

- ① 24 B hoods/housings with 3 modules Conductor cross-section 50 mm<sup>2</sup>  
 ② 24 B hoods/housings with 3 modules Conductor cross-section 70 mm<sup>2</sup>

## Specifications and approvals

EN 60664-1  
 IEC 61984  
 UL 1977 ECBT2.E235076



## Details

Contact resistance crimp contact: ≤ 0.3 mOhm

### Remarks on the axial screw technique

The wire gauges mentioned in the catalogue refer to geometric wire gauges of cables.

Contact resistance axial screw contact: ≤ 0.2 mOhm

for more technical details (i.e. number of crimping operations or crimping position) see eCatalogue

**Crimping tools** see chapter 90





### Remarks on the crimp technique

The wire gauges mentioned in the catalogue refer to geometric wire gauges of cables.

Number of contacts

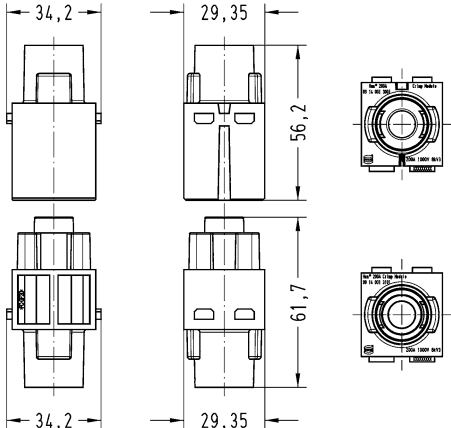
# 1

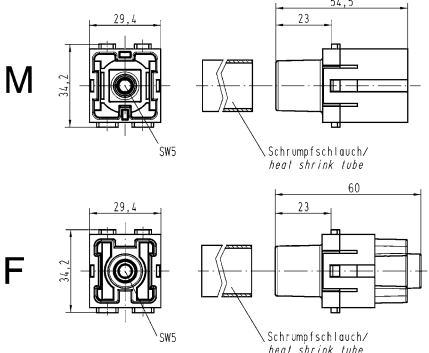
200 A 1.000 V 8 kV 3

Identification	Conductor cross-section (mm <sup>2</sup> )	Part number		Drawing (dimensions in mm)															
		Male	Female																
Han-Modular®, Han® 200 A module, Crimp termination  <p>Please order crimp contacts separately.</p>	25 ... 70	09 14 001 3001	09 14 001 3101	 <p>Removal tool 09 99 000 0820 See chapter 90</p>															
Han-Modular®, Han® 200 A module, Axial screw termination, Contact surface: Silver plated 	25 ... 40 40 ... 70	09 14 001 2663 09 14 001 2662	09 14 001 2763 09 14 001 2762	 <p>Stripping length 16 mm Tightening torque 8 Nm @ 25 ... 40 mm<sup>2</sup>, 9 Nm @ 40 mm<sup>2</sup>, 10 Nm @ 70 mm<sup>2</sup></p>															
TC 200 , Crimp contact, Contact surface: Silver plated 	25 35 50 70	09 11 000 6120 09 11 000 6121 09 11 000 6122 09 11 000 6123	09 11 000 6220 09 11 000 6221 09 11 000 6222 09 11 000 6223	<table border="1"> <thead> <tr> <th>Wire gauge</th> <th>∅</th> <th>Stripping length A</th> </tr> </thead> <tbody> <tr> <td>25 mm<sup>2</sup></td> <td>7</td> <td>19 mm</td> </tr> <tr> <td>35 mm<sup>2</sup></td> <td>8.2</td> <td>20 mm</td> </tr> <tr> <td>50 mm<sup>2</sup></td> <td>10</td> <td>22.5 mm</td> </tr> <tr> <td>70 mm<sup>2</sup></td> <td>11.5</td> <td>22.5 mm</td> </tr> </tbody> </table> <p>for stranded wire according to IEC 60 228 Class 5</p>	Wire gauge	∅	Stripping length A	25 mm <sup>2</sup>	7	19 mm	35 mm <sup>2</sup>	8.2	20 mm	50 mm <sup>2</sup>	10	22.5 mm	70 mm <sup>2</sup>	11.5	22.5 mm
Wire gauge	∅	Stripping length A																	
25 mm <sup>2</sup>	7	19 mm																	
35 mm <sup>2</sup>	8.2	20 mm																	
50 mm <sup>2</sup>	10	22.5 mm																	
70 mm <sup>2</sup>	11.5	22.5 mm																	

Modular

## Technical characteristics

Contact resistance	≤0.2 mΩ
Limiting temperature	-40 ... +125 °C
Flammability acc. to UL 94	V-0
Mating cycles	≥500
Material (insert)	Polycarbonate
Colour (insert)	RAL 7032 (pebble grey)
Material (contacts)	Copper alloy

Modu-  
lar

## Derating

### Current carrying capacity

The current carrying capacity of the connectors is limited by the thermal load capability of the contact element material including the connections and the insulating parts. The derating curve is therefore valid for currents which flow constantly (non-intermittent) through each contact element of the connector evenly, without exceeding the allowed maximum temperature.

Measuring and testing techniques acc. to IEC 60512-5-2

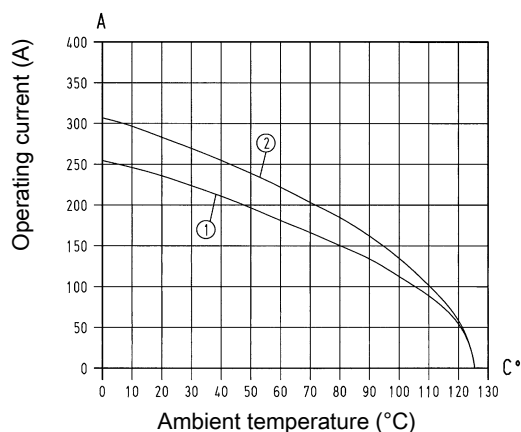

- ① 24 B hoods/housings with 3 modules Conductor cross-section 50 mm<sup>2</sup>
- ② 24 B hoods/housings with 3 modules Conductor cross-section 70 mm<sup>2</sup>

## Specifications and approvals

EN 60664-1  
IEC 61984



Identification	Conductor cross-section (mm <sup>2</sup> )	Part number		Drawing (dimensions in mm)
		Male	Female	
Han-Modular®, Han® 200 A PE module, Axial screw termination, Contact surface: Silver plated	25 ... 40 40 ... 70	09 14 001 2668 09 14 001 2667	09 14 001 2768 09 14 001 2767	<p>                         M                          F                     </p> <p>                         Hex key with grip 09 99 000 0364                          Adapter 3/8" 09 99 000 0371                          See chapter 90                          Stripping length 16 mm                          Tightening torque                          8 Nm @ 25 ... 40 mm<sup>2</sup>, 9 Nm @ 40 mm<sup>2</sup>,                          10 Nm @ 70 mm<sup>2</sup> </p>

Modular

## Features

- Crimp- and axial module are compatible modules
- Contacts can be unlocked from the mating side

## Technical characteristics

Number of contacts	2
Electrical data acc. to IEC 61984	100 A 1.000 V 8 kV 3
Rated current	100 A
Rated voltage	1000 V
Rated impulse voltage	8 kV
Pollution degree	3
Rated voltage acc. to UL	600 V
Insulation resistance	$\geq 10^{10} \Omega$
Contact resistance	$\leq 0.3 \text{ m}\Omega$
Limiting temperature	-40 ... +125 °C
Flammability acc. to UL 94	V-0
Mating cycles	$\geq 500$
Material (insert)	Polycarbonate
Colour (insert)	RAL 7032 (pebble grey)
Material (contacts)	Copper alloy

## Derating

### Current carrying capacity

The current carrying capacity of the connectors is limited by the thermal load capability of the contact element material including the connections and the insulating parts. The derating curve is therefore valid for currents which flow constantly (non-intermittent) through each contact element of the connector evenly, without exceeding the allowed maximum temperature.

Measuring and testing techniques acc. to IEC 60512-5-2

#### Crimp termination

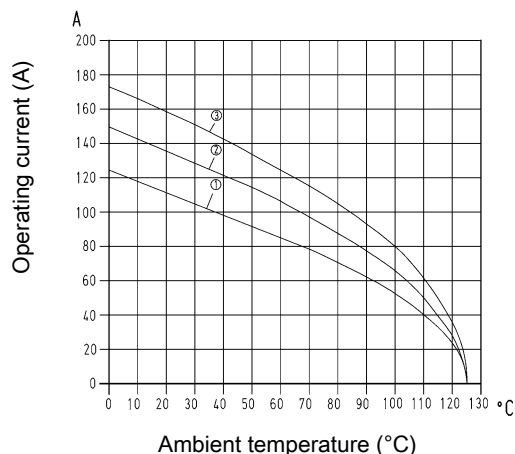

- ① 24 B hoods/housings with 3 modules Conductor cross-section 16 mm<sup>2</sup>
- ② 24 B hoods/housings with 3 modules Conductor cross-section 25 mm<sup>2</sup>
- ③ 24 B hoods/housings with 3 modules Conductor cross-section 35 mm<sup>2</sup>

## Derating

### Axial screw termination

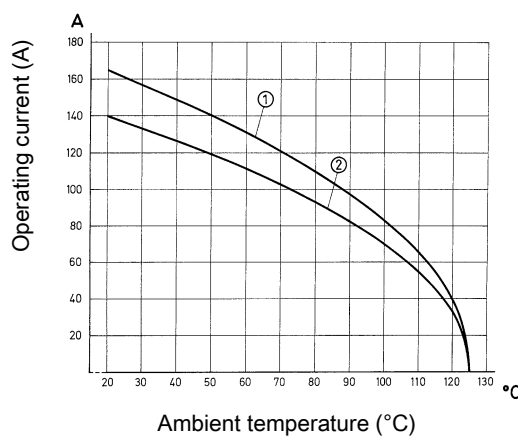

- ① 24 B hoods/housings with 3 modules Conductor cross-section 35 mm<sup>2</sup>
- ② 24 B hoods/housings with 3 modules Conductor cross-section 25 mm<sup>2</sup>

## Specifications and approvals

EN 60664-1  
IEC 61984  
UL 1977 ECBT2.E235076



## Details

for more technical details (i.e. number of crimping operations or crimping position) see eCatalogue

**Crimping tools** see chapter 90

### Remarks on the crimp technique





The wire gauges mentioned in the catalogue refer to geometric wire gauges of cables.

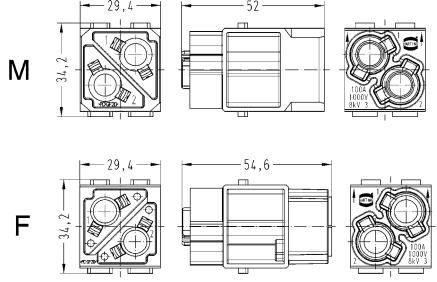

Number of contacts

# 2

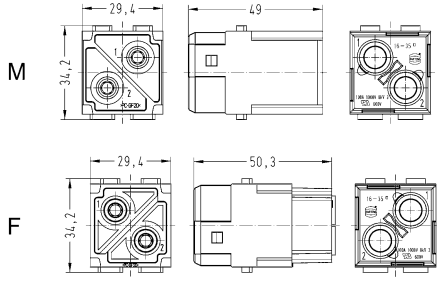
100 A 1.000 V 8 kV 3

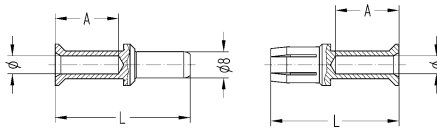
Identification	Conductor cross-section (mm <sup>2</sup> )	Part number		Drawing (dimensions in mm)															
		Male	Female																
Han-Modular®, Han® 100 A module, Crimp termination  <p>Please order crimp contacts separately.</p>	10 ... 35	09 14 002 3051	09 14 002 3151																
Han-Modular®, Han® 100 A module, Axial screw termination, Contact surface: Silver plated 	10 ... 25 16 ... 35 38	09 14 002 2653 09 14 002 2651 09 14 002 2650	09 14 002 2753 09 14 002 2751 09 14 002 2750	 <p>Stripping length 12 ... 14 mm                      Tightening torque                      6 Nm @ 10 ... 16 mm<sup>2</sup>, 7 Nm @ 25 mm<sup>2</sup>,                      8 Nm @ 35 ... 38 mm<sup>2</sup></p>															
TC 100 , Crimp contact, Contact surface: Silver plated 	10 16 25 35	09 11 000 6114 09 11 000 6116 09 11 000 6125 09 11 000 6135	09 11 000 6214 09 11 000 6216 09 11 000 6225 09 11 000 6235	 <table border="1" data-bbox="997 1646 1436 1825"> <thead> <tr> <th>Wire gauge</th> <th>Ø</th> <th>Stripping length A</th> </tr> </thead> <tbody> <tr> <td>10 mm<sup>2</sup></td> <td>4.3</td> <td>19 mm</td> </tr> <tr> <td>16 mm<sup>2</sup></td> <td>5.5</td> <td>19 mm</td> </tr> <tr> <td>25 mm<sup>2</sup></td> <td>7</td> <td>19 mm</td> </tr> <tr> <td>35 mm<sup>2</sup></td> <td>8.2</td> <td>16 mm</td> </tr> </tbody> </table> <p>for stranded wire according to IEC 60 228 Class 5</p>	Wire gauge	Ø	Stripping length A	10 mm <sup>2</sup>	4.3	19 mm	16 mm <sup>2</sup>	5.5	19 mm	25 mm <sup>2</sup>	7	19 mm	35 mm <sup>2</sup>	8.2	16 mm
Wire gauge	Ø	Stripping length A																	
10 mm <sup>2</sup>	4.3	19 mm																	
16 mm <sup>2</sup>	5.5	19 mm																	
25 mm <sup>2</sup>	7	19 mm																	
35 mm <sup>2</sup>	8.2	16 mm																	

Modular

## Features

- Crimp or axial screw termination available
- Unlock of contacts with a screw driver from mating side
- Separate axial screw contacts can be terminated without any special tools directly to the wire

## Technical characteristics

Number of contacts	1
Electrical data acc. to IEC 61984	100 A 830 V 8 kV 3
Rated current	100 A
Rated voltage	830 V
Rated impulse voltage	8 kV
Pollution degree	3
Rated voltage acc. to UL	600 V
Insulation resistance	$\geq 10^{10} \Omega$
Contact resistance	$\leq 0.3 \text{ m}\Omega$
Limiting temperature	-40 ... +125 °C
Flammability acc. to UL 94	V-0
Mating cycles	$\geq 500$
Material (insert)	Polycarbonate
Colour (insert)	RAL 7032 (pebble grey)
Material (contacts)	Copper alloy

## Specifications and approvals

EN 60664-1  
IEC 61984  
UL 1977 ECBT2.E235076



## Details

**Hex key (A/F 4)** see chapter 90

for more technical details (i.e. number of crimping operations or crimping position) see eCatalogue

### Remarks on the axial screw technique

The wire gauges mentioned in the catalogue refer to geometric wire gauges of cables.

**Crimping tools** see chapter 90





### Remarks on the crimp technique

The wire gauges mentioned in the catalogue refer to geometric wire gauges of cables.

Number of contacts

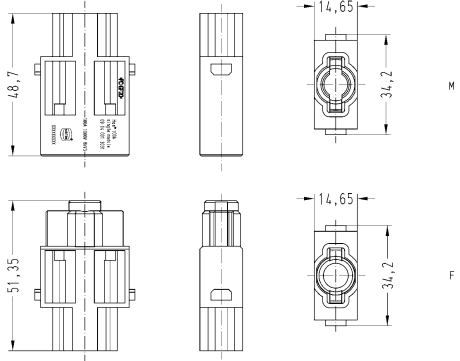
# 1

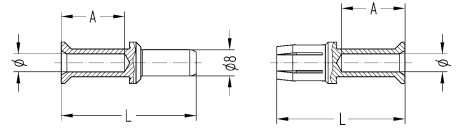
100 A 830 V 8 kV 3

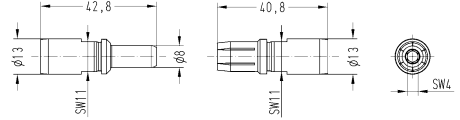
Identification	Conductor cross-section (mm <sup>2</sup> )	Part number		Drawing (dimensions in mm)															
		Male	Female																
Han-Modular®, Han® 100 A module, Single module  <p>Please order contacts separately.</p>	10 ... 35	09 14 001 3031	09 14 001 3131																
TC 100 , Crimp contact, Contact surface: Silver plated 	10 16 25 35	09 11 000 6114 09 11 000 6116 09 11 000 6125 09 11 000 6135	09 11 000 6214 09 11 000 6216 09 11 000 6225 09 11 000 6235	 <table border="1" data-bbox="991 1234 1453 1413"> <thead> <tr> <th>Wire gauge</th> <th>Ø</th> <th>Stripping length A</th> </tr> </thead> <tbody> <tr> <td>10 mm<sup>2</sup></td> <td>4.3</td> <td>19 mm</td> </tr> <tr> <td>16 mm<sup>2</sup></td> <td>5.5</td> <td>19 mm</td> </tr> <tr> <td>25 mm<sup>2</sup></td> <td>7</td> <td>19 mm</td> </tr> <tr> <td>35 mm<sup>2</sup></td> <td>8.2</td> <td>16 mm</td> </tr> </tbody> </table> <p>for stranded wire according to IEC 60 228 Class 5</p>	Wire gauge	Ø	Stripping length A	10 mm <sup>2</sup>	4.3	19 mm	16 mm <sup>2</sup>	5.5	19 mm	25 mm <sup>2</sup>	7	19 mm	35 mm <sup>2</sup>	8.2	16 mm
Wire gauge	Ø	Stripping length A																	
10 mm <sup>2</sup>	4.3	19 mm																	
16 mm <sup>2</sup>	5.5	19 mm																	
25 mm <sup>2</sup>	7	19 mm																	
35 mm <sup>2</sup>	8.2	16 mm																	
TC 100 , Axial screw contact, Contact surface: Silver plated 	10 ... 25 16 ... 35	09 11 000 6112 09 11 000 6113	09 11 000 6212 09 11 000 6213	 <p>Stripping length 13 mm</p> <table border="1" data-bbox="991 1653 1299 1727"> <thead> <tr> <th colspan="5">Tightening torque</th> </tr> <tr> <th>mm<sup>2</sup></th> <th>10</th> <th>16</th> <th>25</th> <th>35</th> </tr> </thead> <tbody> <tr> <td>Nm</td> <td>6</td> <td>6</td> <td>7</td> <td>8</td> </tr> </tbody> </table>	Tightening torque					mm <sup>2</sup>	10	16	25	35	Nm	6	6	7	8
Tightening torque																			
mm <sup>2</sup>	10	16	25	35															
Nm	6	6	7	8															

Modular

## Features

- for power circuits
- Male inserts with protection collar
- Polarisation of module

## Technical characteristics

Number of contacts	2
Electrical data acc. to IEC 61984	70 A 1.000 V 8 kV 3
Rated current	70 A
Rated voltage	1000 V
Rated impulse voltage	8 kV
Pollution degree	3
Insulation resistance	$\geq 10^{10} \Omega$
Contact resistance	$\leq 0.5 \text{ m}\Omega$
Limiting temperature	-40 ... +125 °C
Flammability acc. to UL 94	V-0
Mating cycles	$\geq 500$
Material (insert)	Polycarbonate
Colour (insert)	RAL 7032 (pebble grey)
Material (contacts)	Copper alloy

## Derating

### Current carrying capacity

The current carrying capacity of the connectors is limited by the thermal load capability of the contact element material including the connections and the insulating parts. The derating curve is therefore valid for currents which flow constantly (non-intermittent) through each contact element of the connector evenly, without exceeding the allowed maximum temperature.

Measuring and testing techniques acc. to IEC 60512-5-2

#### Crimp termination



- ① 24 B hoods/housings with 6 modules Conductor cross-section 16 mm<sup>2</sup>
- ② 24 B hoods/housings with 6 modules Conductor cross-section 25 mm<sup>2</sup>

## Derating

### Axial screw termination

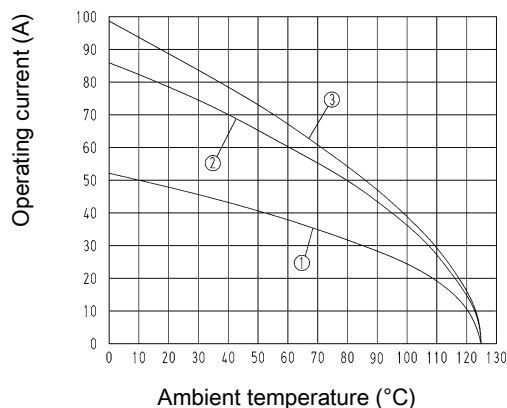

- ① 24 B hoods/housings with 6 modules Conductor cross-section 6 mm<sup>2</sup>
- ② 24 B hoods/housings with 6 modules Conductor cross-section 16 mm<sup>2</sup>
- ③ 24 B hoods/housings with 6 modules Conductor cross-section 22 mm<sup>2</sup>

## Specifications and approvals

EN 60664-1  
IEC 61984  
UL 1977 ECBT2.E235076



## Details

### Remarks on the axial screw technique

The wire gauges mentioned in the catalogue refer to geometric wire gauges of cables.

**Hex key (A/F 2.5)** see chapter 90

for more technical details (i.e. number of crimping operations or crimping position) see eCatalogue

**Crimping tools** see chapter 90



### Remarks on the crimp technique

The wire gauges mentioned in the catalogue refer to geometric wire gauges of cables.

Number of contacts

# 2

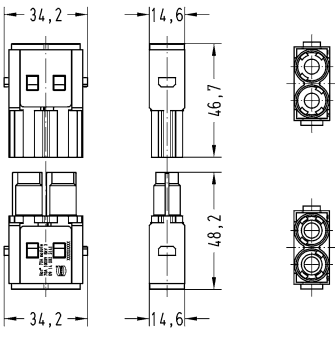
70 A 1.000 V 8 kV 3

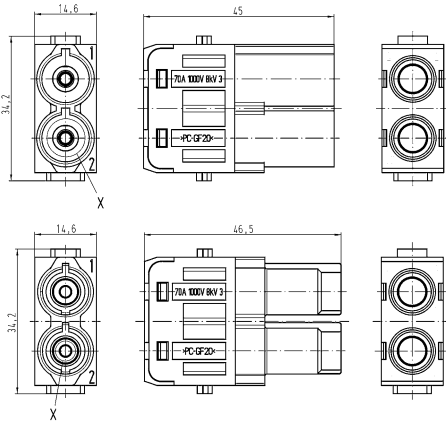
Identification	Conductor cross-section (mm <sup>2</sup> )	Part number		Drawing (dimensions in mm)		
		Male	Female			
<p>Han-Modular®, Han® 70 A module, Crimp termination</p>  <p>Please order crimp contacts separately.</p>	10 ... 25	09 14 002 3041	09 14 002 3141			
<p>Han-Modular®, Han® 70 A module, Axial screw termination, Contact surface: Silver plated</p>  <p>Finger safe</p> <p>Han-Modular®, Han® 70 A module, Axial screw termination, Contact surface: Silver plated</p> 	6 ... 16 14 ... 22	09 14 002 2641 09 14 002 2642				
						<p>6 ... 16 mm<sup>2</sup>: Stripping length 11 ... 12 mm                      14 ... 22 mm<sup>2</sup>: Stripping length 12,5 ... 13.5 mm                      Tightening torque                      2 Nm @ 6 mm<sup>2</sup>, 3 Nm @ 10 mm<sup>2</sup>, 4 Nm @ 14 mm<sup>2</sup>, 4 Nm @ 16 mm<sup>2</sup>, 4 Nm @ 22 mm<sup>2</sup></p>

Modular

Identification	Conductor cross-section (mm <sup>2</sup> )	Part number		Drawing (dimensions in mm)												
		Male	Female													
TC 70 , Crimp contact, Contact surface: Silver plated	10 16 25	09 11 000 6131 09 11 000 6132 09 11 000 6133	09 11 000 6231 09 11 000 6232 09 11 000 6233	 <table border="1"> <thead> <tr> <th>Wire gauge</th> <th>∅</th> <th>Stripping length A</th> </tr> </thead> <tbody> <tr> <td>10 mm<sup>2</sup></td> <td>4.3</td> <td>15.5 mm</td> </tr> <tr> <td>16 mm<sup>2</sup></td> <td>5.5</td> <td>15.5 mm</td> </tr> <tr> <td>25 mm<sup>2</sup></td> <td>7</td> <td>15.5 mm</td> </tr> </tbody> </table> for stranded wire according to IEC 60 228 Class 5	Wire gauge	∅	Stripping length A	10 mm <sup>2</sup>	4.3	15.5 mm	16 mm <sup>2</sup>	5.5	15.5 mm	25 mm <sup>2</sup>	7	15.5 mm
Wire gauge	∅	Stripping length A														
10 mm <sup>2</sup>	4.3	15.5 mm														
16 mm <sup>2</sup>	5.5	15.5 mm														
25 mm <sup>2</sup>	7	15.5 mm														

Modular

## Features

- Axial screw termination
- for power circuits
- Male inserts with protection collar
- Polarisation of module

## Technical characteristics

Number of contacts	1
Additional contacts	+ 4 additional signal contacts
Electrical data acc. to IEC 61984	70 A 1.000 V 8 kV 3
Rated current	70 A
Rated voltage	1000 V
Rated impulse voltage	8 kV
Pollution degree	3
Electrical data, signal	16 A 400 V 6 kV 3
Rated current (signal)	16 A
Rated voltage (signal)	400 V
Rated impulse voltage (signal)	6 kV
Pollution degree (signal)	3
Insulation resistance	$\geq 10^{10} \Omega$
Contact resistance	$\leq 1 \text{ m}\Omega$
Limiting temperature	-40 ... +125 °C
Flammability acc. to UL 94	V-0
Mating cycles	$\geq 500$
Material (insert)	Polycarbonate
Colour (insert)	RAL 7032 (pebble grey)
Material (contacts)	Copper alloy

## Specifications and approvals

EN 60664-1  
IEC 61984  
UL 1977 ECBT2.E235076



## Details

**Hex key (A/F 2.5)** see chapter 90

### Remarks on the axial screw technique

The wire gauges mentioned in the catalogue refer to geometric wire gauges of cables.

**Crimping tools** see chapter 90

### Remarks on the crimp technique



The wire gauges mentioned in the catalogue refer to geometric wire gauges of cables.

Number of contacts

# 1

70 A 1.000 V 8 kV 3  
 + 4 additional signal contacts  
 16 A 400 V 6 kV 3

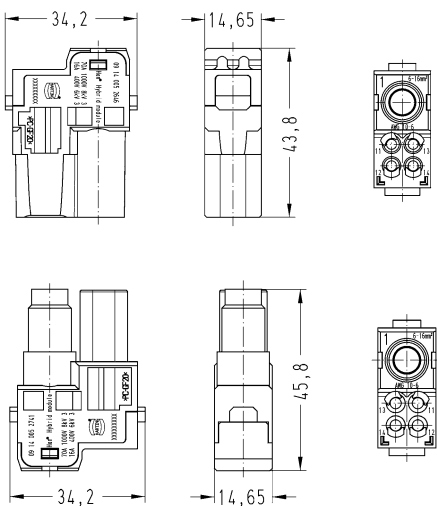
Modu-  
lar

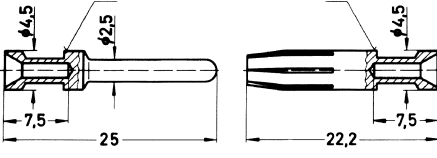
Identification	Conductor cross-section (mm <sup>2</sup> )	Part number		Drawing (dimensions in mm)																											
		Male	Female																												
Han-Modular®, Han® 70 A Hybrid module, Axial screw termination / crimp termination  <p>Please order signal contacts separately.</p>	6 ... 16 14 ... 22	09 14 005 2646 09 14 005 2647	09 14 005 2741 09 14 005 2742	 <p>6 ... 16 mm<sup>2</sup>: Stripping length 11 ... 12 mm                      14 ... 22 mm<sup>2</sup>: Stripping length 12,5 ... 13.5 mm                      Tightening torque                      2 Nm @ 6 mm<sup>2</sup>, 3 Nm @ 10 mm<sup>2</sup>, 4 Nm @ 14 mm<sup>2</sup>, 4 Nm @ 16 mm<sup>2</sup>, 4 Nm @ 22 mm<sup>2</sup></p>																											
Han E®, Crimp contact, Contact surface: Silver plated 	0,14 ... 0,37 0,5 0,75 1 1,5 2,5 3 4	09 33 000 6127 09 33 000 6121 09 33 000 6114 09 33 000 6105 09 33 000 6104 09 33 000 6102 09 33 000 6106 09 33 000 6107	09 33 000 6227 09 33 000 6220 09 33 000 6214 09 33 000 6205 09 33 000 6204 09 33 000 6202 09 33 000 6206 09 33 000 6207	 <table border="1"> <thead> <tr> <th>Conductor cross-section</th> <th>AWG</th> <th>Identification</th> </tr> </thead> <tbody> <tr> <td>0.14-0.37 mm<sup>2</sup></td> <td>AWG 26-22</td> <td>no groove</td> </tr> <tr> <td>0.5 mm<sup>2</sup></td> <td>AWG 20</td> <td>no groove</td> </tr> <tr> <td>0.75 mm<sup>2</sup></td> <td>AWG 18</td> <td>1 groove*</td> </tr> <tr> <td>1 mm<sup>2</sup></td> <td>AWG 18</td> <td>1 groove</td> </tr> <tr> <td>1.5 mm<sup>2</sup></td> <td>AWG 16</td> <td>2 grooves</td> </tr> <tr> <td>2.5 mm<sup>2</sup></td> <td>AWG 14</td> <td>3 grooves</td> </tr> <tr> <td>3 mm<sup>2</sup></td> <td>AWG 12</td> <td>wide groove</td> </tr> <tr> <td>4 mm<sup>2</sup></td> <td>AWG 12</td> <td>no groove</td> </tr> </tbody> </table> <p>* on the back crimp collar                      Stripping length 7.5 mm</p>	Conductor cross-section	AWG	Identification	0.14-0.37 mm <sup>2</sup>	AWG 26-22	no groove	0.5 mm <sup>2</sup>	AWG 20	no groove	0.75 mm <sup>2</sup>	AWG 18	1 groove*	1 mm <sup>2</sup>	AWG 18	1 groove	1.5 mm <sup>2</sup>	AWG 16	2 grooves	2.5 mm <sup>2</sup>	AWG 14	3 grooves	3 mm <sup>2</sup>	AWG 12	wide groove	4 mm <sup>2</sup>	AWG 12	no groove
Conductor cross-section	AWG	Identification																													
0.14-0.37 mm <sup>2</sup>	AWG 26-22	no groove																													
0.5 mm <sup>2</sup>	AWG 20	no groove																													
0.75 mm <sup>2</sup>	AWG 18	1 groove*																													
1 mm <sup>2</sup>	AWG 18	1 groove																													
1.5 mm <sup>2</sup>	AWG 16	2 grooves																													
2.5 mm <sup>2</sup>	AWG 14	3 grooves																													
3 mm <sup>2</sup>	AWG 12	wide groove																													
4 mm <sup>2</sup>	AWG 12	no groove																													



Identification	Conductor cross-section (mm <sup>2</sup> )	Part number		Drawing (dimensions in mm)																		
		Male	Female																			
Han E® , Crimp contact, Contact surface: Gold plated	0,14 ... 0,37	09 33 000 6117	09 33 000 6217																			
	0,5	09 33 000 6122	09 33 000 6222																			
	0,75	09 33 000 6115	09 33 000 6215																			
	1	09 33 000 6118	09 33 000 6218																			
	1,5	09 33 000 6116	09 33 000 6216																			
	2,5	09 33 000 6123	09 33 000 6223																			
	4	09 33 000 6119	09 33 000 6221																			
		<table border="1"> <thead> <tr> <th>Conductor cross-section</th> <th>Identification</th> </tr> </thead> <tbody> <tr> <td>0.14-0.37 mm<sup>2</sup></td> <td>AWG 26-22 no groove</td> </tr> <tr> <td>0.5 mm<sup>2</sup></td> <td>AWG 20 no groove</td> </tr> <tr> <td>0.75 mm<sup>2</sup></td> <td>AWG 18 1 groove*</td> </tr> <tr> <td>1 mm<sup>2</sup></td> <td>AWG 18 1 groove</td> </tr> <tr> <td>1.5 mm<sup>2</sup></td> <td>AWG 16 2 grooves</td> </tr> <tr> <td>2.5 mm<sup>2</sup></td> <td>AWG 14 3 grooves</td> </tr> <tr> <td>3 mm<sup>2</sup></td> <td>AWG 12 wide groove</td> </tr> <tr> <td>4 mm<sup>2</sup></td> <td>AWG 12 no groove</td> </tr> </tbody> </table>		Conductor cross-section	Identification	0.14-0.37 mm <sup>2</sup>	AWG 26-22 no groove	0.5 mm <sup>2</sup>	AWG 20 no groove	0.75 mm <sup>2</sup>	AWG 18 1 groove*	1 mm <sup>2</sup>	AWG 18 1 groove	1.5 mm <sup>2</sup>	AWG 16 2 grooves	2.5 mm <sup>2</sup>	AWG 14 3 grooves	3 mm <sup>2</sup>	AWG 12 wide groove	4 mm <sup>2</sup>	AWG 12 no groove	
Conductor cross-section	Identification																					
0.14-0.37 mm <sup>2</sup>	AWG 26-22 no groove																					
0.5 mm <sup>2</sup>	AWG 20 no groove																					
0.75 mm <sup>2</sup>	AWG 18 1 groove*																					
1 mm <sup>2</sup>	AWG 18 1 groove																					
1.5 mm <sup>2</sup>	AWG 16 2 grooves																					
2.5 mm <sup>2</sup>	AWG 14 3 grooves																					
3 mm <sup>2</sup>	AWG 12 wide groove																					
4 mm <sup>2</sup>	AWG 12 no groove																					
		* on the back crimp collar Stripping length 7.5 mm																				

Modu-  
lar

## Features

- Crimp or axial screw termination available
- No special tools required for axial-screw termination

## Technical characteristics

Number of contacts	2
Electrical data acc. to IEC 61984	40 A 1.000 V 8 kV 3
Rated current	40 A
Rated voltage	1000 V
Rated impulse voltage	8 kV
Pollution degree	3
Rated voltage acc. to UL	600 V
Insulation resistance	$\geq 10^{10} \Omega$
Contact resistance	$\leq 0.3 \text{ m}\Omega, \leq 1 \text{ m}\Omega$
Limiting temperature	-40 ... +125 °C
Flammability acc. to UL 94	V-0
Mating cycles	$\geq 500$
Material (insert)	Polycarbonate
Colour (insert)	RAL 7032 (pebble grey)
Material (contacts)	Copper alloy

## Derating

### Current carrying capacity

The current carrying capacity of the connectors is limited by the thermal load capability of the contact element material including the connections and the insulating parts. The derating curve is therefore valid for currents which flow constantly (non-intermittent) through each contact element of the connector evenly, without exceeding the allowed maximum temperature.

Measuring and testing techniques acc. to IEC 60512-5-2

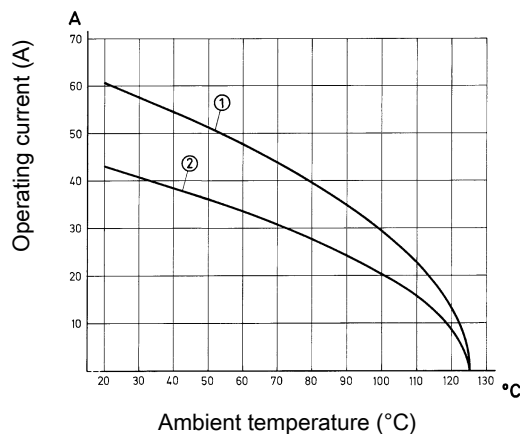

- ① 24 B hoods/housings with 6 modules Conductor cross-section 10 mm<sup>2</sup>
- ② 24 B hoods/housings with 6 modules Conductor cross-section 6 mm<sup>2</sup>

## Specifications and approvals

EN 60664-1  
IEC 61984  
UL 1977 ECBT2.E235076



## Details

Contact resistance Han® C crimp contact:  $\leq 0.3 \text{ m}\Omega$

Contact resistance axial screw contact:  $\leq 0.3 \text{ m}\Omega$

**Hex key (A/F 2)** see chapter 90

### Remarks on the axial screw technique

The wire gauges mentioned in the catalogue refer to geometric wire gauges of cables.

**Crimping tools** see chapter 90



### Remarks on the crimp technique

The wire gauges mentioned in the catalogue refer to geometric wire gauges of cables.

Number of contacts

# 2

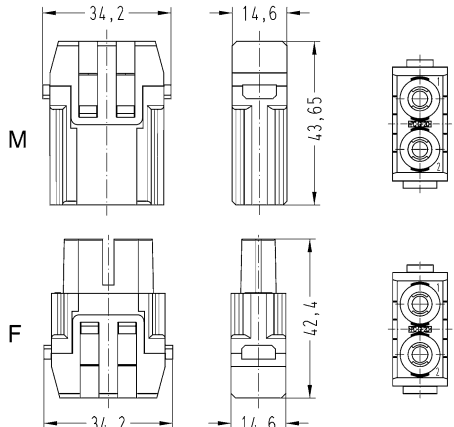
40 A 1.000 V 8 kV 3

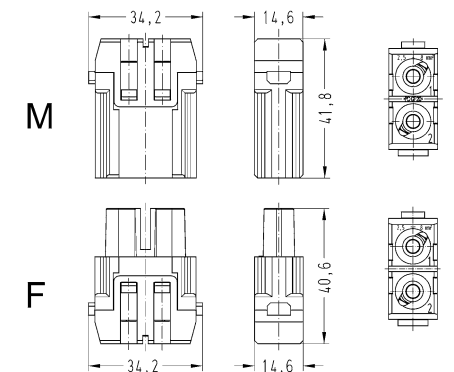
Identification	Conductor cross-section (mm <sup>2</sup> )	Part number		Drawing (dimensions in mm)																				
		Male	Female																					
Han-Modular®, Han® 40 A module, Crimp termination  <p>Please order crimp contacts separately.</p>	1,5 ... 10	09 14 002 3002	09 14 002 3102	 <p>Contact arrangement (view from termination side)</p>																				
Han-Modular®, Han® 40 A module, Axial screw termination, Contact surface: Silver plated 	2,5 ... 8 6 ... 10	09 14 002 2601 09 14 002 2602	09 14 002 2701 09 14 002 2702	 <p>Contact arrangement (view from termination side)</p> <p><b>Stripping length</b></p> <table border="1"> <tr> <td>mm<sup>2</sup></td> <td>2,5</td> <td>4</td> <td>6</td> <td>10</td> </tr> <tr> <td>mm</td> <td>5<sup>1</sup></td> <td>5<sup>1</sup></td> <td>8<sup>1</sup></td> <td>11<sup>1</sup></td> </tr> </table> <p><b>Tightening torque</b></p> <table border="1"> <tr> <td>mm<sup>2</sup></td> <td>2,5</td> <td>4</td> <td>6</td> <td>10</td> </tr> <tr> <td>Nm</td> <td>1,5</td> <td>1,5</td> <td>2</td> <td>2</td> </tr> </table>	mm <sup>2</sup>	2,5	4	6	10	mm	5 <sup>1</sup>	5 <sup>1</sup>	8 <sup>1</sup>	11 <sup>1</sup>	mm <sup>2</sup>	2,5	4	6	10	Nm	1,5	1,5	2	2
mm <sup>2</sup>	2,5	4	6	10																				
mm	5 <sup>1</sup>	5 <sup>1</sup>	8 <sup>1</sup>	11 <sup>1</sup>																				
mm <sup>2</sup>	2,5	4	6	10																				
Nm	1,5	1,5	2	2																				

Modular

Identification	Conductor cross-section (mm <sup>2</sup> )	Part number		Drawing (dimensions in mm)																		
		Male	Female																			
Han® C , Crimp contact, Contact surface: Silver plated	1,5	09 32 000 6104	09 32 000 6204																			
	2,5	09 32 000 6105	09 32 000 6205																			
	4	09 32 000 6107	09 32 000 6207																			
	6	09 32 000 6108	09 32 000 6208																			
	10	09 32 000 6109	09 32 000 6209																			
				<table border="1"> <thead> <tr> <th>Conductor cross-section</th> <th>Ø</th> <th>Stripping length</th> </tr> </thead> <tbody> <tr> <td>1.5 mm<sup>2</sup> AWG 16</td> <td>1.75 mm</td> <td>9.5 mm</td> </tr> <tr> <td>2.5 mm<sup>2</sup> AWG 14</td> <td>2.25 mm</td> <td>9.5 mm</td> </tr> <tr> <td>4 mm<sup>2</sup> AWG 12</td> <td>2.85 mm</td> <td>9.5 mm</td> </tr> <tr> <td>6 mm<sup>2</sup> AWG 10</td> <td>3.5 mm</td> <td>9.5 mm</td> </tr> <tr> <td>10 mm<sup>2</sup> AWG 8</td> <td>4.3 mm</td> <td>12 mm</td> </tr> </tbody> </table>	Conductor cross-section	Ø	Stripping length	1.5 mm <sup>2</sup> AWG 16	1.75 mm	9.5 mm	2.5 mm <sup>2</sup> AWG 14	2.25 mm	9.5 mm	4 mm <sup>2</sup> AWG 12	2.85 mm	9.5 mm	6 mm <sup>2</sup> AWG 10	3.5 mm	9.5 mm	10 mm <sup>2</sup> AWG 8	4.3 mm	12 mm
Conductor cross-section	Ø	Stripping length																				
1.5 mm <sup>2</sup> AWG 16	1.75 mm	9.5 mm																				
2.5 mm <sup>2</sup> AWG 14	2.25 mm	9.5 mm																				
4 mm <sup>2</sup> AWG 12	2.85 mm	9.5 mm																				
6 mm <sup>2</sup> AWG 10	3.5 mm	9.5 mm																				
10 mm <sup>2</sup> AWG 8	4.3 mm	12 mm																				

Modu-  
lar

## Features

- Standard module for power up to 40 A
- No special tools required for axial-screw termination

## Technical characteristics

Number of contacts	3
Electrical data acc. to IEC 61984	40 A 690 V 8 kV 3
Rated current	40 A
Rated voltage	690 V
Rated impulse voltage	8 kV
Pollution degree	3
Rated current acc. to UL	40 A
Rated voltage acc. to UL	600 V
Insulation resistance	$\geq 10^{10} \Omega$
Contact resistance	$\leq 0.3 \text{ m}\Omega, \leq 1 \text{ m}\Omega$
Limiting temperature	-40 ... +125 °C
Flammability acc. to UL 94	V-0
Mating cycles	$\geq 500$
Material (insert)	Polycarbonate
Colour (insert)	RAL 7032 (pebble grey)
Material (contacts)	Copper alloy

## Derating

### Current carrying capacity

The current carrying capacity of the connectors is limited by the thermal load capability of the contact element material including the connections and the insulating parts. The derating curve is therefore valid for currents which flow constantly (non-intermittent) through each contact element of the connector evenly, without exceeding the allowed maximum temperature.

Measuring and testing techniques acc. to IEC 60512-5-2

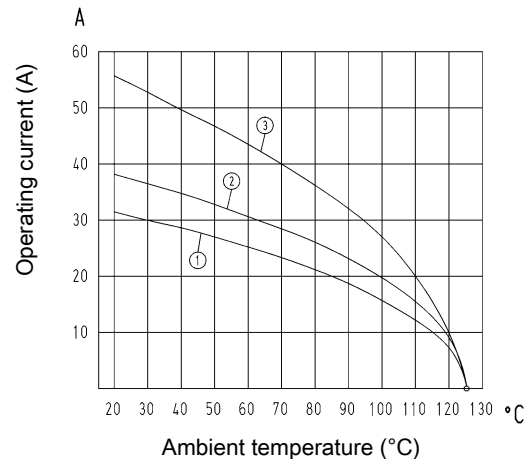

- ① 24 B hoods/housings with 6 modules Conductor cross-section 4 mm<sup>2</sup>
- ② 24 B hoods/housings with 6 modules Conductor cross-section 6 mm<sup>2</sup>
- ③ 24 B hoods/housings with 6 modules Conductor cross-section 10 mm<sup>2</sup>

## Specifications and approvals

EN 60664-1  
IEC 61984  
UL 1977 ECBT2.E235076



## Details

Contact resistance Han® C crimp contact:  $\leq 0.3 \text{ m}\Omega$

Contact resistance axial screw contact:  $\leq 0.3 \text{ m}\Omega$

**Hex key (A/F 2)** see chapter 90

### Remarks on the axial screw technique

The wire gauges mentioned in the catalogue refer to geometric wire gauges of cables.

**Crimping tools** see chapter 90

### Remarks on the crimp technique





The wire gauges mentioned in the catalogue refer to geometric wire gauges of cables.

Number of contacts

# 3

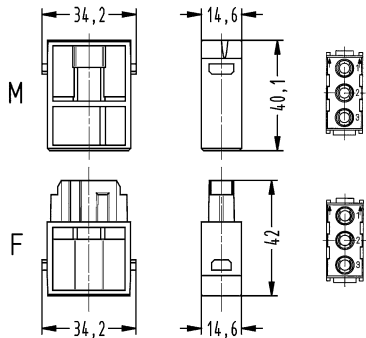
40 A 690 V 8 kV 3

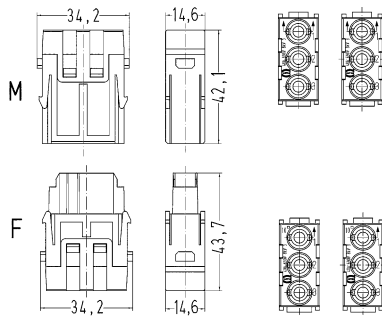
Modular

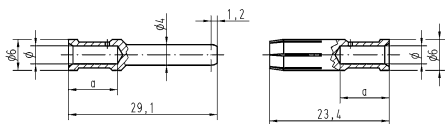
Identification	Conductor cross-section (mm <sup>2</sup> )	Part number		Drawing (dimensions in mm)																														
		Male	Female																															
Han-Modular®, Han® C module, Crimp termination  Please order crimp contacts separately.	1,5 ... 6	09 14 003 3001	09 14 003 3101	 Contact arrangement (view from termination side)																														
Han-Modular®, Han® C module, Axial screw termination, Contact surface: Silver plated 	2,5 ... 8 6 ... 10	09 14 003 2601 09 14 003 2602	09 14 003 2701 09 14 003 2702	 <table border="1"> <thead> <tr> <th colspan="5">Stripping length</th> </tr> <tr> <th>mm<sup>2</sup></th> <th>2,5</th> <th>4</th> <th>6</th> <th>10</th> </tr> </thead> <tbody> <tr> <td>mm</td> <td>5<sup>+1</sup></td> <td>5<sup>+1</sup></td> <td>8<sup>+1</sup></td> <td>11<sup>+1</sup></td> </tr> </tbody> </table> <table border="1"> <thead> <tr> <th colspan="5">Tightening torque</th> </tr> <tr> <th>mm<sup>2</sup></th> <th>2,5</th> <th>4</th> <th>6</th> <th>10</th> </tr> </thead> <tbody> <tr> <td>Nm</td> <td>1,5</td> <td>1,5</td> <td>2</td> <td>2</td> </tr> </tbody> </table>	Stripping length					mm <sup>2</sup>	2,5	4	6	10	mm	5 <sup>+1</sup>	5 <sup>+1</sup>	8 <sup>+1</sup>	11 <sup>+1</sup>	Tightening torque					mm <sup>2</sup>	2,5	4	6	10	Nm	1,5	1,5	2	2
Stripping length																																		
mm <sup>2</sup>	2,5	4	6	10																														
mm	5 <sup>+1</sup>	5 <sup>+1</sup>	8 <sup>+1</sup>	11 <sup>+1</sup>																														
Tightening torque																																		
mm <sup>2</sup>	2,5	4	6	10																														
Nm	1,5	1,5	2	2																														
Han® C, Crimp contact, Contact surface: Silver plated 	1,5 2,5 4 6	09 32 000 6104 09 32 000 6105 09 32 000 6107 09 32 000 6108	09 32 000 6204 09 32 000 6205 09 32 000 6207 09 32 000 6208	 <table border="1"> <thead> <tr> <th>Conductor cross-section</th> <th>Ø</th> <th>Stripping length</th> </tr> </thead> <tbody> <tr> <td>1.5 mm<sup>2</sup> AWG 16</td> <td>1.75 mm</td> <td>9.5 mm</td> </tr> <tr> <td>2.5 mm<sup>2</sup> AWG 14</td> <td>2.25 mm</td> <td>9.5 mm</td> </tr> <tr> <td>4 mm<sup>2</sup> AWG 12</td> <td>2.85 mm</td> <td>9.5 mm</td> </tr> <tr> <td>6 mm<sup>2</sup> AWG 10</td> <td>3.5 mm</td> <td>9.5 mm</td> </tr> <tr> <td>10 mm<sup>2</sup> AWG 8</td> <td>4.3 mm</td> <td>12 mm</td> </tr> </tbody> </table>	Conductor cross-section	Ø	Stripping length	1.5 mm <sup>2</sup> AWG 16	1.75 mm	9.5 mm	2.5 mm <sup>2</sup> AWG 14	2.25 mm	9.5 mm	4 mm <sup>2</sup> AWG 12	2.85 mm	9.5 mm	6 mm <sup>2</sup> AWG 10	3.5 mm	9.5 mm	10 mm <sup>2</sup> AWG 8	4.3 mm	12 mm												
Conductor cross-section	Ø	Stripping length																																
1.5 mm <sup>2</sup> AWG 16	1.75 mm	9.5 mm																																
2.5 mm <sup>2</sup> AWG 14	2.25 mm	9.5 mm																																
4 mm <sup>2</sup> AWG 12	2.85 mm	9.5 mm																																
6 mm <sup>2</sup> AWG 10	3.5 mm	9.5 mm																																
10 mm <sup>2</sup> AWG 8	4.3 mm	12 mm																																

## Features

- Suitable for Han® C crimp contacts
- Designed for a high working voltage up to 830 V
- Finger safe male and female contacts
- High density of contacts

## Technical characteristics

Number of contacts	4
Electrical data acc. to IEC 61984	40 A 830 V 8 kV 3
Rated current	40 A
Rated voltage	830 V
Rated impulse voltage	8 kV
Pollution degree	3
Rated voltage acc. to UL	600 V
Insulation resistance	$\geq 10^{10} \Omega$
Contact resistance	$\leq 1 \text{ m}\Omega$
Limiting temperature	-40 ... +125 °C
Flammability acc. to UL 94	V-0
Mating cycles	$\geq 500$
Material (insert)	Polycarbonate
Colour (insert)	RAL 7032 (pebble grey)
Material (contacts)	Copper alloy

## Derating

### Current carrying capacity

The current carrying capacity of the connectors is limited by the thermal load capability of the contact element material including the connections and the insulating parts. The derating curve is therefore valid for currents which flow constantly (non-intermittent) through each contact element of the connector evenly, without exceeding the allowed maximum temperature.

Measuring and testing techniques acc. to IEC 60512-5-2

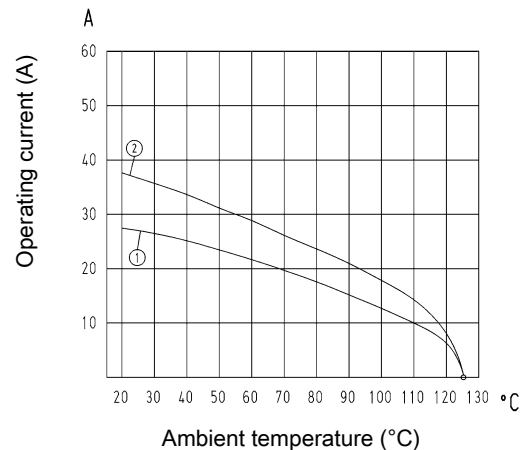

- ① 24 B hoods/housings with 6 modules Conductor cross-section 4 mm<sup>2</sup>  
 ② 24 B hoods/housings with 6 modules Conductor cross-section 6 mm<sup>2</sup>

## Specifications and approvals

EN 60664-1  
 IEC 61984  
 UL 1977 ECBT2.E235076



## Details

**Crimping tools** see chapter 90

### Remarks on the crimp technique



The wire gauges mentioned in the catalogue refer to geometric wire gauges of cables.

Number of contacts

# 4

40 A 830 V 8 kV 3

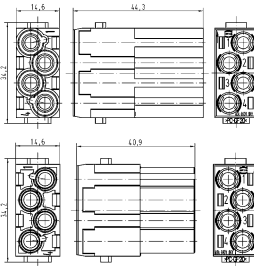
Modular

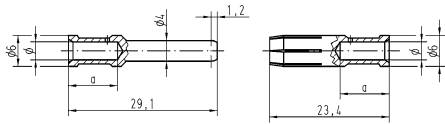
Identification	Conductor cross-section (mm <sup>2</sup> )	Part number		Drawing (dimensions in mm)																		
		Male	Female																			
Han-Modular®, Han® CC Protected module, Crimp termination  <p>Please order crimp contacts separately.</p>	1,5 ... 6	09 14 004 3041	09 14 004 3141																			
Han® C, Crimp contact, Contact surface: Silver plated 	1,5 2,5 4 6	09 32 000 6104 09 32 000 6105 09 32 000 6107 09 32 000 6108	09 32 000 6204 09 32 000 6205 09 32 000 6207 09 32 000 6208	  <table border="1"> <thead> <tr> <th>Conductor cross-section</th> <th>Ø</th> <th>Stripping length</th> </tr> </thead> <tbody> <tr> <td>1.5 mm<sup>2</sup> AWG 16</td> <td>1.75 mm</td> <td>9.5 mm</td> </tr> <tr> <td>2.5 mm<sup>2</sup> AWG 14</td> <td>2.25 mm</td> <td>9.5 mm</td> </tr> <tr> <td>4 mm<sup>2</sup> AWG 12</td> <td>2.85 mm</td> <td>9.5 mm</td> </tr> <tr> <td>6 mm<sup>2</sup> AWG 10</td> <td>3.5 mm</td> <td>9.5 mm</td> </tr> <tr> <td>10 mm<sup>2</sup> AWG 8</td> <td>4.3 mm</td> <td>12 mm</td> </tr> </tbody> </table>	Conductor cross-section	Ø	Stripping length	1.5 mm <sup>2</sup> AWG 16	1.75 mm	9.5 mm	2.5 mm <sup>2</sup> AWG 14	2.25 mm	9.5 mm	4 mm <sup>2</sup> AWG 12	2.85 mm	9.5 mm	6 mm <sup>2</sup> AWG 10	3.5 mm	9.5 mm	10 mm <sup>2</sup> AWG 8	4.3 mm	12 mm
Conductor cross-section	Ø	Stripping length																				
1.5 mm <sup>2</sup> AWG 16	1.75 mm	9.5 mm																				
2.5 mm <sup>2</sup> AWG 14	2.25 mm	9.5 mm																				
4 mm <sup>2</sup> AWG 12	2.85 mm	9.5 mm																				
6 mm <sup>2</sup> AWG 10	3.5 mm	9.5 mm																				
10 mm <sup>2</sup> AWG 8	4.3 mm	12 mm																				



## Features

- 3 contacts (40 A) for power circuits and 4 contacts (10 A) for signal circuits
- Ideal as motor drive connector
- Finger safe male and female contacts

## Technical characteristics

Number of contacts	3
Additional contacts	+ 4 additional signal contacts
Electrical data acc. to IEC 61984	40 A 830 V 8 kV 3
Rated current	40 A
Rated voltage	830 V
Rated impulse voltage	8 kV
Pollution degree	3
Electrical data, signal	10 A 830 V 8 kV 3
Rated current (signal)	10 A
Rated voltage (signal)	830 V
Rated impulse voltage (signal)	8 kV
Pollution degree (signal)	3
Rated voltage acc. to UL	600 V
Insulation resistance	$\geq 10^{10} \Omega$
Contact resistance	$\leq 1 \text{ m}\Omega, \leq 3 \text{ m}\Omega$
Limiting temperature	-40 ... +125 °C
Flammability acc. to UL 94	V-0
Mating cycles	$\geq 500$
Material (insert)	Polycarbonate
Colour (insert)	RAL 7032 (pebble grey)
Material (contacts)	Copper alloy

## Derating

### Current carrying capacity

The current carrying capacity of the connectors is limited by the thermal load capability of the contact element material including the connections and the insulating parts. The derating curve is therefore valid for currents which flow constantly (non-intermittent) through each contact element of the connector evenly, without exceeding the allowed maximum temperature.

Measuring and testing techniques acc. to IEC 60512-5-2

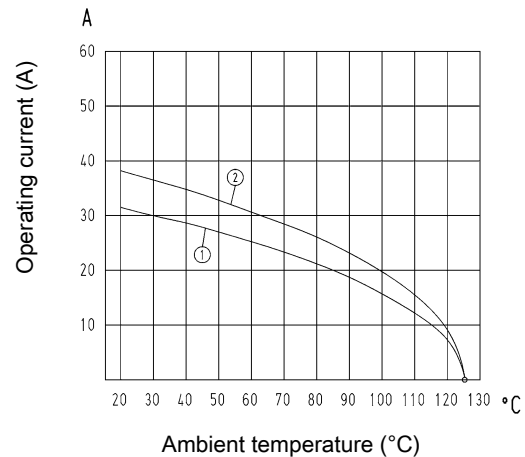

- ① 24 B hoods/housings with 6 modules Conductor cross-section 4 mm<sup>2</sup>
- ② 24 B hoods/housings with 6 modules Conductor cross-section 6 mm<sup>2</sup>

## Specifications and approvals

EN 60664-1  
IEC 61984  
UL 1977 ECBT2.E235076



## Details

Contact resistance Han D® crimp contact:  $\leq 3 \text{ m}\Omega$

Contact resistance Han® C crimp contact:  $\leq 0.3 \text{ m}\Omega$

**Crimping tools** see chapter 90

### Remarks on the crimp technique





The wire gauges mentioned in the catalogue refer to geometric wire gauges of cables.

Number of contacts

# 3

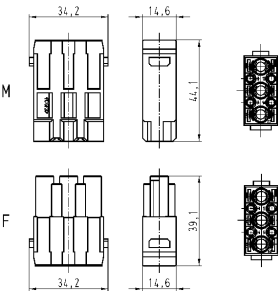
40 A 830 V 8 kV 3  
 + 4 additional signal contacts  
 10 A 830 V 8 kV 3

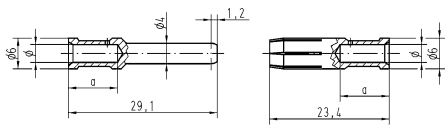
Modular

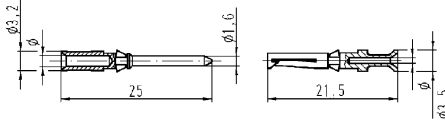
Identification	Conductor cross-section (mm <sup>2</sup> )	Part number		Drawing (dimensions in mm)																					
		Male	Female																						
Han-Modular®, Han® CD module, Crimp termination  <p>Please order crimp contacts separately.</p>	0,14 ... 6	09 14 007 3001	09 14 007 3101	 <p>Contact arrangement (view from termination side)                      max. insulation diameter 5 mm</p>																					
Han® C , Crimp contact, Contact surface: Silver plated 	1,5 2,5 4 6	09 32 000 6104 09 32 000 6105 09 32 000 6107 09 32 000 6108	09 32 000 6204 09 32 000 6205 09 32 000 6207 09 32 000 6208	 <table border="1"> <thead> <tr> <th>Conductor cross-section</th> <th>Ø</th> <th>Stripping length</th> </tr> </thead> <tbody> <tr> <td>1.5 mm<sup>2</sup> AWG 16</td> <td>1.75 mm</td> <td>9.5 mm</td> </tr> <tr> <td>2.5 mm<sup>2</sup> AWG 14</td> <td>2.25 mm</td> <td>9.5 mm</td> </tr> <tr> <td>4 mm<sup>2</sup> AWG 12</td> <td>2.85 mm</td> <td>9.5 mm</td> </tr> <tr> <td>6 mm<sup>2</sup> AWG 10</td> <td>3.5 mm</td> <td>9.5 mm</td> </tr> <tr> <td>10 mm<sup>2</sup> AWG 8</td> <td>4.3 mm</td> <td>12 mm</td> </tr> </tbody> </table>	Conductor cross-section	Ø	Stripping length	1.5 mm <sup>2</sup> AWG 16	1.75 mm	9.5 mm	2.5 mm <sup>2</sup> AWG 14	2.25 mm	9.5 mm	4 mm <sup>2</sup> AWG 12	2.85 mm	9.5 mm	6 mm <sup>2</sup> AWG 10	3.5 mm	9.5 mm	10 mm <sup>2</sup> AWG 8	4.3 mm	12 mm			
Conductor cross-section	Ø	Stripping length																							
1.5 mm <sup>2</sup> AWG 16	1.75 mm	9.5 mm																							
2.5 mm <sup>2</sup> AWG 14	2.25 mm	9.5 mm																							
4 mm <sup>2</sup> AWG 12	2.85 mm	9.5 mm																							
6 mm <sup>2</sup> AWG 10	3.5 mm	9.5 mm																							
10 mm <sup>2</sup> AWG 8	4.3 mm	12 mm																							
Han D®, Crimp contact, Contact surface: Silver plated 	0,14 ... 0,37 0,5 0,75 1 1,5 2,5	09 15 000 6104 09 15 000 6103 09 15 000 6105 09 15 000 6102 09 15 000 6101 09 15 000 6106	09 15 000 6204 09 15 000 6203 09 15 000 6205 09 15 000 6202 09 15 000 6201 09 15 000 6206	 <table border="1"> <thead> <tr> <th>Wire gauge</th> <th>Ø</th> <th>Stripping length</th> </tr> </thead> <tbody> <tr> <td>0.14-0.37 mm<sup>2</sup> AWG 26-22</td> <td>0.9 mm</td> <td>8 mm</td> </tr> <tr> <td>0.5 mm<sup>2</sup> AWG 20</td> <td>1.1 mm</td> <td>8 mm</td> </tr> <tr> <td>0.75 mm<sup>2</sup> AWG 18</td> <td>1.3 mm</td> <td>8 mm</td> </tr> <tr> <td>1 mm<sup>2</sup> AWG 18</td> <td>1.45 mm</td> <td>8 mm</td> </tr> <tr> <td>1.5 mm<sup>2</sup> AWG 16</td> <td>1.75 mm</td> <td>8 mm</td> </tr> <tr> <td>2.5 mm<sup>2</sup> AWG 14</td> <td>2.25 mm</td> <td>6 mm</td> </tr> </tbody> </table>	Wire gauge	Ø	Stripping length	0.14-0.37 mm <sup>2</sup> AWG 26-22	0.9 mm	8 mm	0.5 mm <sup>2</sup> AWG 20	1.1 mm	8 mm	0.75 mm <sup>2</sup> AWG 18	1.3 mm	8 mm	1 mm <sup>2</sup> AWG 18	1.45 mm	8 mm	1.5 mm <sup>2</sup> AWG 16	1.75 mm	8 mm	2.5 mm <sup>2</sup> AWG 14	2.25 mm	6 mm
Wire gauge	Ø	Stripping length																							
0.14-0.37 mm <sup>2</sup> AWG 26-22	0.9 mm	8 mm																							
0.5 mm <sup>2</sup> AWG 20	1.1 mm	8 mm																							
0.75 mm <sup>2</sup> AWG 18	1.3 mm	8 mm																							
1 mm <sup>2</sup> AWG 18	1.45 mm	8 mm																							
1.5 mm <sup>2</sup> AWG 16	1.75 mm	8 mm																							
2.5 mm <sup>2</sup> AWG 14	2.25 mm	6 mm																							

Identification	Conductor cross-section (mm <sup>2</sup> )	Part number		Drawing (dimensions in mm)																					
		Male	Female																						
Han D®, Crimp contact, Contact surface: Gold plated	0,14 ... 0,37	09 15 000 6124	09 15 000 6224																						
	0,5	09 15 000 6123	09 15 000 6223																						
	0,75	09 15 000 6125	09 15 000 6225																						
	1	09 15 000 6122	09 15 000 6222																						
	1,5	09 15 000 6121	09 15 000 6221																						
	2,5	09 15 000 6126	09 15 000 6226																						
				<table border="1"> <thead> <tr> <th>Wire gauge</th> <th>Ø</th> <th>Stripping length</th> </tr> </thead> <tbody> <tr> <td>0.14-0.37 mm<sup>2</sup> AWG 26-22</td> <td>0.9 mm</td> <td>8 mm</td> </tr> <tr> <td>0.5 mm<sup>2</sup> AWG 20</td> <td>1.1 mm</td> <td>8 mm</td> </tr> <tr> <td>0.75 mm<sup>2</sup> AWG 18</td> <td>1.3 mm</td> <td>8 mm</td> </tr> <tr> <td>1 mm<sup>2</sup> AWG 18</td> <td>1.45 mm</td> <td>8 mm</td> </tr> <tr> <td>1.5 mm<sup>2</sup> AWG 16</td> <td>1.75 mm</td> <td>8 mm</td> </tr> <tr> <td>2.5 mm<sup>2</sup> AWG 14</td> <td>2.25 mm</td> <td>6 mm</td> </tr> </tbody> </table>	Wire gauge	Ø	Stripping length	0.14-0.37 mm <sup>2</sup> AWG 26-22	0.9 mm	8 mm	0.5 mm <sup>2</sup> AWG 20	1.1 mm	8 mm	0.75 mm <sup>2</sup> AWG 18	1.3 mm	8 mm	1 mm <sup>2</sup> AWG 18	1.45 mm	8 mm	1.5 mm <sup>2</sup> AWG 16	1.75 mm	8 mm	2.5 mm <sup>2</sup> AWG 14	2.25 mm	6 mm
Wire gauge	Ø	Stripping length																							
0.14-0.37 mm <sup>2</sup> AWG 26-22	0.9 mm	8 mm																							
0.5 mm <sup>2</sup> AWG 20	1.1 mm	8 mm																							
0.75 mm <sup>2</sup> AWG 18	1.3 mm	8 mm																							
1 mm <sup>2</sup> AWG 18	1.45 mm	8 mm																							
1.5 mm <sup>2</sup> AWG 16	1.75 mm	8 mm																							
2.5 mm <sup>2</sup> AWG 14	2.25 mm	6 mm																							

Modular

## Features

- Standard module for power up to 16 A
- Han-Quick Lock® or crimp termination available

## Technical characteristics

Number of contacts	6
Electrical data acc. to IEC 61984	16 A 500 V 6 kV 3
Rated current	16 A
Rated voltage	500 V
Rated impulse voltage	6 kV
Pollution degree	3
Rated voltage acc. to UL	600 V
Insulation resistance	≥10 <sup>10</sup> Ω
Contact resistance	≤1 mΩ
Limiting temperature	-40 ... +125 °C
Flammability acc. to UL 94	V-0
Mating cycles	≥500
Mating cycles with other HMC components	≥10000
Material (insert)	Polycarbonate
Colour (insert)	RAL 7032 (pebble grey)
Material (contacts)	Copper alloy

Modular

## Derating

### Current carrying capacity

The current carrying capacity of the connectors is limited by the thermal load capability of the contact element material including the connections and the insulating parts. The derating curve is therefore valid for currents which flow constantly (non-intermittent) through each contact element of the connector evenly, without exceeding the allowed maximum temperature.

Measuring and testing techniques acc. to IEC 60512-5-2

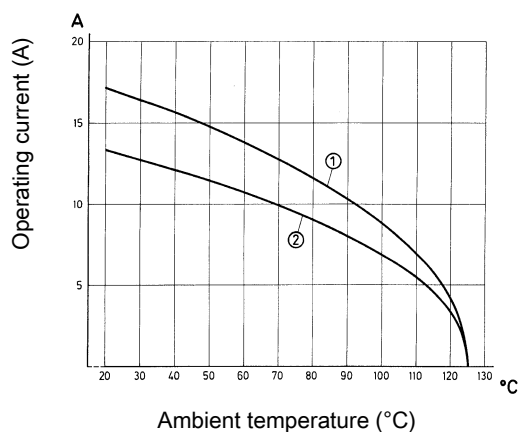

- ① 24 B hoods/housings with 6 modules Conductor cross-section 2.5 mm<sup>2</sup>
- ② 24 B hoods/housings with 6 modules Conductor cross-section 1.5 mm<sup>2</sup>

## Specifications and approvals

EN 60664-1  
IEC 61984  
UL 1977 ECBT2.E235076



## Details

**Crimping tools** see chapter 90



### Remarks on the crimp technique

The wire gauges mentioned in the catalogue refer to geometric wire gauges of cables.

Number of contacts

# 6

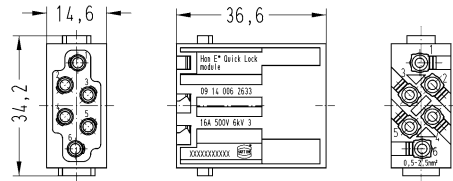
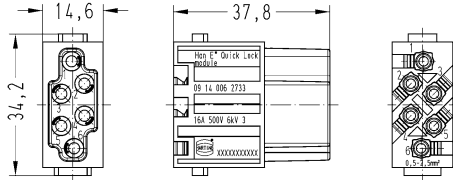
16 A 500 V 6 kV 3

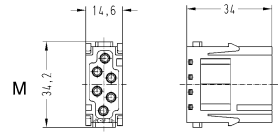
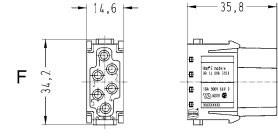
Identification	Conductor cross-section (mm <sup>2</sup> )	Part number		Drawing (dimensions in mm)
		Male	Female	
<p>Han-Modular®, Han E® module, Han-Quick Lock® termination, Contact surface: Silver plated</p> 	0,5 ... 2,5	09 14 006 2633	09 14 006 2733	 <p>Contact arrangement (view from termination side)</p> 
<p>Han-Modular®, Han E® module, Crimp termination</p>  <p>Please order crimp contacts separately.</p>	0,14 ... 4	09 14 006 3001	09 14 006 3101	  <p>Contact arrangement (view from termination side)</p>

Modular

Modular

Identification	Conductor cross-section (mm <sup>2</sup> )	Part number	
		Male	Female
Han E®, Crimp contact, Contact surface: Silver plated	0,14 ... 0,37	09 33 000 6127	09 33 000 6227
	0,5	09 33 000 6121	09 33 000 6220
	0,75	09 33 000 6114	09 33 000 6214
	1	09 33 000 6105	09 33 000 6205
	1,5	09 33 000 6104	09 33 000 6204
	2,5	09 33 000 6102	09 33 000 6202
	3	09 33 000 6106	09 33 000 6206
	4	09 33 000 6107	09 33 000 6207

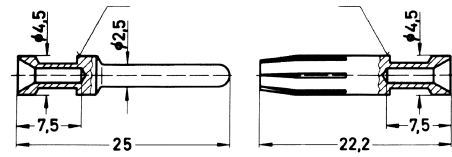

Conductor cross-section	AWG	Identification
0.14-0.37 mm <sup>2</sup>	AWG 26-22	no groove
0.5 mm <sup>2</sup>	AWG 20	no groove
0.75 mm <sup>2</sup>	AWG 18	1 groove*
1 mm <sup>2</sup>	AWG 18	1 groove
1.5 mm <sup>2</sup>	AWG 16	2 grooves
2.5 mm <sup>2</sup>	AWG 14	3 grooves
3 mm <sup>2</sup>	AWG 12	wide groove
4 mm <sup>2</sup>	AWG 12	no groove

\* on the back crimp collar

Stripping length 7.5 mm

Identification	Conductor cross-section (mm <sup>2</sup> )	Part number	
		Male	Female
Han E®, Crimp contact, Contact surface: Gold plated	0,14 ... 0,37	09 33 000 6117	09 33 000 6217
	0,5	09 33 000 6122	09 33 000 6222
	0,75	09 33 000 6115	09 33 000 6215
	1	09 33 000 6118	09 33 000 6218
	1,5	09 33 000 6116	09 33 000 6216
	2,5	09 33 000 6123	09 33 000 6223
	3	09 33 000 6119	09 33 000 6219
	4	09 33 000 6119	09 33 000 6221

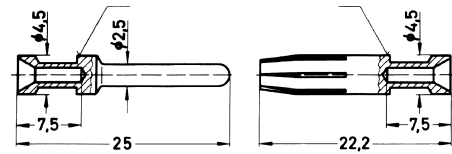

Conductor cross-section	AWG	Identification
0.14-0.37 mm <sup>2</sup>	AWG 26-22	no groove
0.5 mm <sup>2</sup>	AWG 20	no groove
0.75 mm <sup>2</sup>	AWG 18	1 groove*
1 mm <sup>2</sup>	AWG 18	1 groove
1.5 mm <sup>2</sup>	AWG 16	2 grooves
2.5 mm <sup>2</sup>	AWG 14	3 grooves
3 mm <sup>2</sup>	AWG 12	wide groove
4 mm <sup>2</sup>	AWG 12	no groove

\* on the back crimp collar

Stripping length 7.5 mm

Number of contacts

# 5

16 A 230/400 V 4 kV 3

## Features

- Screw connection, suitable for all users around the world
- No special tools required
- for flexible and solid conductors from 0.5 to 2.5 mm<sup>2</sup>
- Additional protection against voltage and accidental contact by a sliding insulation cover which closes automatically during mating.

## Technical characteristics

Number of contacts	5
Electrical data acc. to IEC 61984	16 A 230/400 V 4 kV 3
Rated current	16 A
Rated voltage conductor-earth	230 V
Rated voltage conductor-conductor	400 V
Rated impulse voltage	4 kV
Pollution degree	3
Insulation resistance	≥10 <sup>10</sup> Ω
Contact resistance	≤1 mΩ
Limiting temperature	-40 ... +125 °C
Flammability acc. to UL 94	V-0
Mating cycles	≥500
Material (insert)	Polycarbonate
Colour (insert)	RAL 7032 (pebble grey)
Material (contacts)	Copper alloy

## Derating

### Current carrying capacity

The current carrying capacity of the connectors is limited by the thermal load capability of the contact element material including the connections and the insulating parts. The derating curve is therefore valid for currents which flow constantly (non-intermittent) through each contact element of the connector evenly, without exceeding the allowed maximum temperature.

Measuring and testing techniques acc. to IEC 60512-5-2

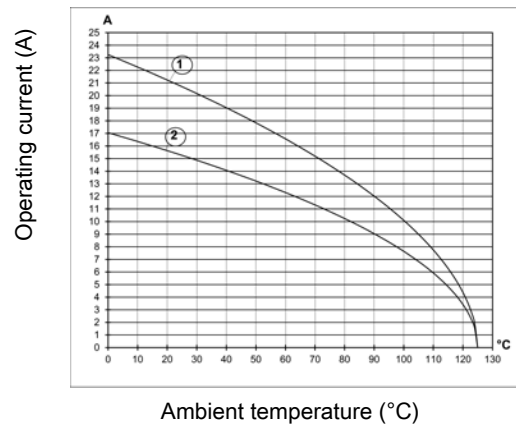

- ① Conductor cross-section 2.5 mm<sup>2</sup>
- ② Conductor cross-section 1.5 mm<sup>2</sup>

## Specifications and approvals

EN 60664-1  
IEC 61984



Identification	Conductor cross-section (mm <sup>2</sup> )	Part number		Drawing (dimensions in mm)
		Male	Female	
Han-Modular®, Han E® module, Screw termination, Contact surface: Silver plated  	0,5 ... 2,5	09 14 005 2601	09 14 005 2701	<p>Stripping length 7.5 mm Tightening torque 0.5 Nm</p>

## Features

- Suitable for Han E® crimp contacts
- Designed for a high working voltage up to 830 V
- Finger safe male and female contacts

## Technical characteristics

Number of contacts	6
Electrical data acc. to IEC 61984	16 A 830 V 8 kV 3
Rated current	16 A
Rated voltage	830 V
Rated impulse voltage	8 kV
Pollution degree	3
Rated voltage acc. to UL	600 V
Insulation resistance	$\geq 10^{10} \Omega$
Contact resistance	$\leq 1 \text{ m}\Omega$
Limiting temperature	-40 ... +125 °C
Flammability acc. to UL 94	V-0
Mating cycles	$\geq 500$
Mating cycles with other HMC components	$\geq 10000$
Material (insert)	Polycarbonate
Colour (insert)	RAL 7032 (pebble grey)
Material (contacts)	Copper alloy

Modular

## Derating

### Current carrying capacity

The current carrying capacity of the connectors is limited by the thermal load capability of the contact element material including the connections and the insulating parts. The derating curve is therefore valid for currents which flow constantly (non-intermittent) through each contact element of the connector evenly, without exceeding the allowed maximum temperature.

Measuring and testing techniques acc. to IEC 60512-5-2

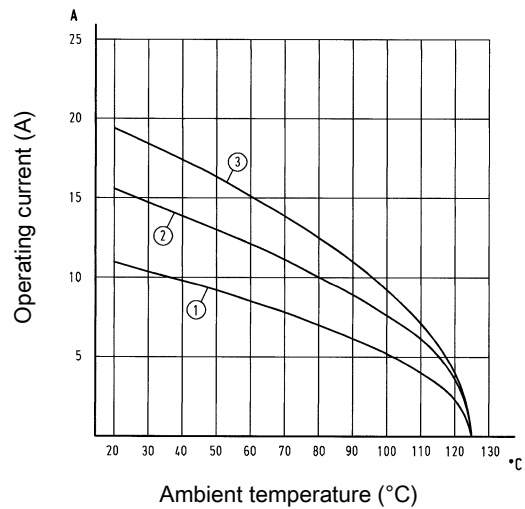

- ① 24 B hoods/housings with 6 modules Conductor cross-section 1.5 mm<sup>2</sup>
- ② 24 B hoods/housings with 6 modules Conductor cross-section 2.5 mm<sup>2</sup>
- ③ 24 B hoods/housings with 6 modules Conductor cross-section 4 mm<sup>2</sup>

## Specifications and approvals

EN 60664-1  
IEC 61984  
UL 1977 ECBT2.E235076



## Details

**Crimping tools** see chapter 90

### Remarks on the crimp technique



The wire gauges mentioned in the catalogue refer to geometric wire gauges of cables.



Number of contacts

# 6

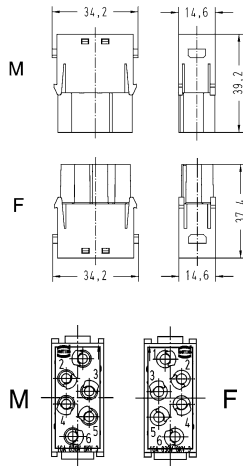
16 A 830 V 8 kV 3

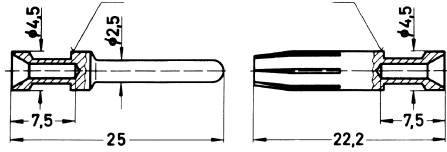
Identification	Conductor cross-section (mm <sup>2</sup> )	Part number		Drawing (dimensions in mm)																											
		Male	Female																												
Han-Modular®, Han E® Protected module, Crimp termination  <p>Please order crimp contacts separately.</p>	0,14 ... 4	09 14 006 3041	09 14 006 3141	 <p>Contact arrangement (view from termination side)</p>																											
Han E®, Crimp contact, Contact surface: Silver plated 	0,14 ... 0,37 0,5 0,75 1 1,5 2,5 3 4	09 33 000 6127 09 33 000 6121 09 33 000 6114 09 33 000 6105 09 33 000 6104 09 33 000 6102 09 33 000 6106 09 33 000 6107	09 33 000 6227 09 33 000 6220 09 33 000 6214 09 33 000 6205 09 33 000 6204 09 33 000 6202 09 33 000 6206 09 33 000 6207	 <table border="1"> <thead> <tr> <th>Conductor cross-section</th> <th>AWG</th> <th>Identification</th> </tr> </thead> <tbody> <tr> <td>0.14-0.37 mm<sup>2</sup></td> <td>AWG 26-22</td> <td>no groove</td> </tr> <tr> <td>0.5 mm<sup>2</sup></td> <td>AWG 20</td> <td>no groove</td> </tr> <tr> <td>0.75 mm<sup>2</sup></td> <td>AWG 18</td> <td>1 groove*</td> </tr> <tr> <td>1 mm<sup>2</sup></td> <td>AWG 18</td> <td>1 groove</td> </tr> <tr> <td>1.5 mm<sup>2</sup></td> <td>AWG 16</td> <td>2 grooves</td> </tr> <tr> <td>2.5 mm<sup>2</sup></td> <td>AWG 14</td> <td>3 grooves</td> </tr> <tr> <td>3 mm<sup>2</sup></td> <td>AWG 12</td> <td>wide groove</td> </tr> <tr> <td>4 mm<sup>2</sup></td> <td>AWG 12</td> <td>no groove</td> </tr> </tbody> </table> <p>* on the back crimp collar Stripping length 7.5 mm</p>	Conductor cross-section	AWG	Identification	0.14-0.37 mm <sup>2</sup>	AWG 26-22	no groove	0.5 mm <sup>2</sup>	AWG 20	no groove	0.75 mm <sup>2</sup>	AWG 18	1 groove*	1 mm <sup>2</sup>	AWG 18	1 groove	1.5 mm <sup>2</sup>	AWG 16	2 grooves	2.5 mm <sup>2</sup>	AWG 14	3 grooves	3 mm <sup>2</sup>	AWG 12	wide groove	4 mm <sup>2</sup>	AWG 12	no groove
Conductor cross-section	AWG	Identification																													
0.14-0.37 mm <sup>2</sup>	AWG 26-22	no groove																													
0.5 mm <sup>2</sup>	AWG 20	no groove																													
0.75 mm <sup>2</sup>	AWG 18	1 groove*																													
1 mm <sup>2</sup>	AWG 18	1 groove																													
1.5 mm <sup>2</sup>	AWG 16	2 grooves																													
2.5 mm <sup>2</sup>	AWG 14	3 grooves																													
3 mm <sup>2</sup>	AWG 12	wide groove																													
4 mm <sup>2</sup>	AWG 12	no groove																													

Modular

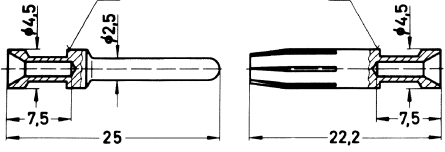
Identification	Conductor cross-section (mm <sup>2</sup> )	Part number		Drawing (dimensions in mm)
		Male	Female	
Han E®, Crimp contact, Contact surface: Gold plated 	0,14 ... 0,37	09 33 000 6117	09 33 000 6217	
	0,5	09 33 000 6122	09 33 000 6222	
	0,75	09 33 000 6115	09 33 000 6215	
	1	09 33 000 6118	09 33 000 6218	
	1,5	09 33 000 6116	09 33 000 6216	
	2,5	09 33 000 6123	09 33 000 6223	
	4	09 33 000 6119	09 33 000 6221	

Conductor cross-section	AWG	Identification
0.14-0.37 mm <sup>2</sup>	AWG 26-22	no groove
0.5 mm <sup>2</sup>	AWG 20	no groove
0.75 mm <sup>2</sup>	AWG 18	1 groove*
1 mm <sup>2</sup>	AWG 18	1 groove
1.5 mm <sup>2</sup>	AWG 16	2 grooves
2.5 mm <sup>2</sup>	AWG 14	3 grooves
3 mm <sup>2</sup>	AWG 12	wide groove
4 mm <sup>2</sup>	AWG 12	no groove

\* on the back crimp collar

Stripping length 7.5 mm

Modular

## Features

- Han-Quick Lock® or crimp termination available
- High packing density

## Technical characteristics

Number of contacts	8
Electrical data acc. to IEC 61984	16 A 400 V 6 kV 3
Rated current	16 A
Rated voltage	400 V
Rated impulse voltage	6 kV
Pollution degree	3
Rated voltage acc. to UL	600 V
Insulation resistance	$\geq 10^{10} \Omega$
Contact resistance	$\leq 1 \text{ m}\Omega$
Limiting temperature	-40 ... +125 °C
Flammability acc. to UL 94	V-0
Mating cycles	$\geq 500$
Mating cycles with other HMC components	$\geq 10000$
Material (insert)	Polycarbonate
Colour (insert)	RAL 7032 (pebble grey)
Material (contacts)	Copper alloy

## Derating

### Current carrying capacity

The current carrying capacity of the connectors is limited by the thermal load capability of the contact element material including the connections and the insulating parts. The derating curve is therefore valid for currents which flow constantly (non-intermittent) through each contact element of the connector evenly, without exceeding the allowed maximum temperature.

Measuring and testing techniques acc. to IEC 60512-5-2

Han-Quick Lock® termination

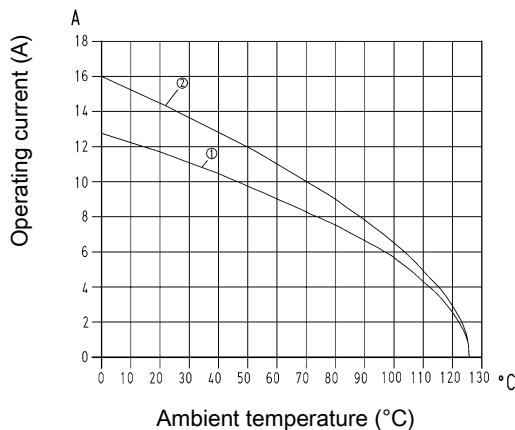

- ① 24 B hoods/housings with 6 modules Conductor cross-section 1.5 mm<sup>2</sup>
- ② 24 B hoods/housings with 6 modules Conductor cross-section 2.5 mm<sup>2</sup>

## Derating

### Crimp termination

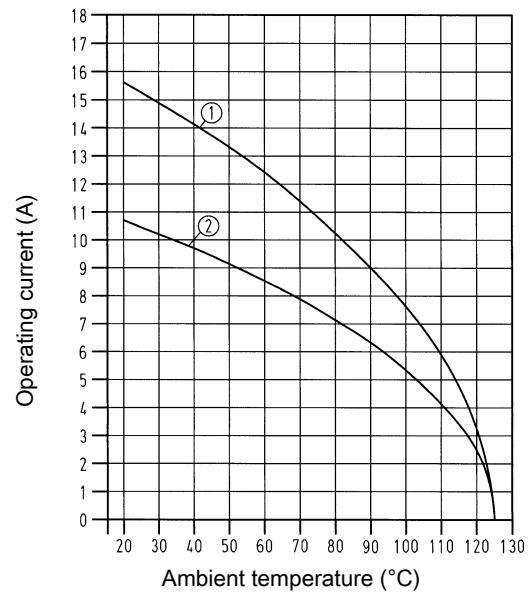

- ① 24 B hoods/housings with 6 modules Conductor cross-section 2.5 mm<sup>2</sup>
- ② 24 B hoods/housings with 6 modules Conductor cross-section 1.5 mm<sup>2</sup>

## Specifications and approvals

EN 60664-1  
IEC 61984  
UL 1977 ECBT2.E235076



## Details

**Crimping tools** see chapter 90

### Remarks on the crimp technique



The wire gauges mentioned in the catalogue refer to geometric wire gauges of cables.



Number of contacts

# 8

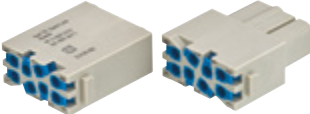
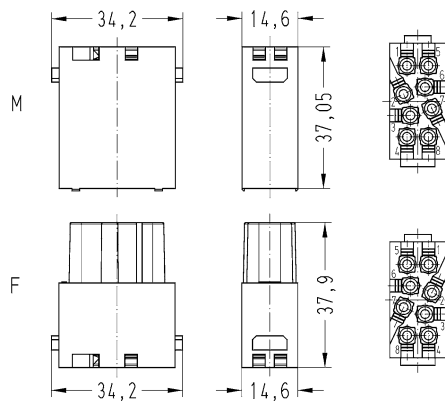
16 A 400 V 6 kV 3

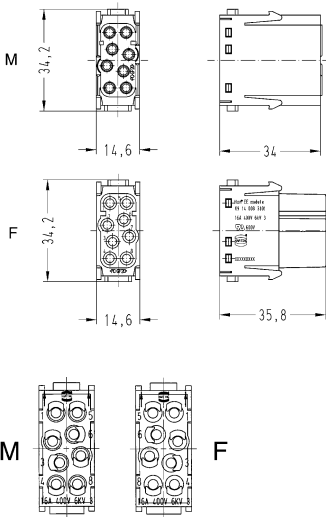
Modular

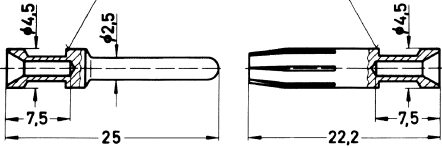
Identification	Conductor cross-section (mm <sup>2</sup> )	Part number		Drawing (dimensions in mm)
		Male	Female	
<p>Han-Modular®, Han® EE module, Han-Quick Lock® termination, Contact surface: Silver plated</p>  <p>Blue slide</p>	0,5 ... 2,5	09 14 008 2633	09 14 008 2733	 <p>Contact arrangement (view from termination side) Stripping length 10 mm</p>
<p>Han-Modular®, Han® EE module, Han-Quick Lock® termination, Contact surface: Silver plated Black slide</p>	0,25 ... 1,5	09 14 008 2634	09 14 008 2734	
<p>Han-Modular®, Han® EE module, Crimp termination</p>  <p>Please order crimp contacts separately.</p>	0,14 ... 4	09 14 008 3001	09 14 008 3101	 <p>Contact arrangement (view from termination side) Stripping length 7.5 mm</p>

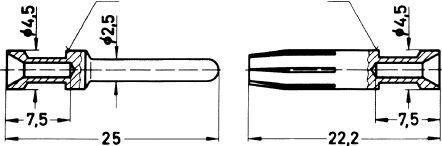
Identification	Conductor cross-section (mm <sup>2</sup> )	Part number		Drawing (dimensions in mm)																	
		Male	Female																		
Han E®, Crimp contact, Contact surface: Silver plated 	0,14 ... 0,37	09 33 000 6127	09 33 000 6227																		
	0,5	09 33 000 6121	09 33 000 6220																		
	0,75	09 33 000 6114	09 33 000 6214																		
	1	09 33 000 6105	09 33 000 6205																		
	1,5	09 33 000 6104	09 33 000 6204																		
	2,5	09 33 000 6102	09 33 000 6202																		
	3	09 33 000 6106	09 33 000 6206																		
	4	09 33 000 6107	09 33 000 6207																		
		<table border="1"> <thead> <tr> <th>Conductor cross-section</th> <th>Identification</th> </tr> </thead> <tbody> <tr> <td>0.14-0.37 mm<sup>2</sup></td> <td>AWG 26-22 no groove</td> </tr> <tr> <td>0.5 mm<sup>2</sup></td> <td>AWG 20 no groove</td> </tr> <tr> <td>0.75 mm<sup>2</sup></td> <td>AWG 18 1 groove*</td> </tr> <tr> <td>1 mm<sup>2</sup></td> <td>AWG 18 1 groove</td> </tr> <tr> <td>1.5 mm<sup>2</sup></td> <td>AWG 16 2 grooves</td> </tr> <tr> <td>2.5 mm<sup>2</sup></td> <td>AWG 14 3 grooves</td> </tr> <tr> <td>3 mm<sup>2</sup></td> <td>AWG 12 wide groove</td> </tr> <tr> <td>4 mm<sup>2</sup></td> <td>AWG 12 no groove</td> </tr> </tbody> </table> * on the back crimp collar Stripping length 7.5 mm		Conductor cross-section	Identification	0.14-0.37 mm <sup>2</sup>	AWG 26-22 no groove	0.5 mm <sup>2</sup>	AWG 20 no groove	0.75 mm <sup>2</sup>	AWG 18 1 groove*	1 mm <sup>2</sup>	AWG 18 1 groove	1.5 mm <sup>2</sup>	AWG 16 2 grooves	2.5 mm <sup>2</sup>	AWG 14 3 grooves	3 mm <sup>2</sup>	AWG 12 wide groove	4 mm <sup>2</sup>	AWG 12 no groove
Conductor cross-section	Identification																				
0.14-0.37 mm <sup>2</sup>	AWG 26-22 no groove																				
0.5 mm <sup>2</sup>	AWG 20 no groove																				
0.75 mm <sup>2</sup>	AWG 18 1 groove*																				
1 mm <sup>2</sup>	AWG 18 1 groove																				
1.5 mm <sup>2</sup>	AWG 16 2 grooves																				
2.5 mm <sup>2</sup>	AWG 14 3 grooves																				
3 mm <sup>2</sup>	AWG 12 wide groove																				
4 mm <sup>2</sup>	AWG 12 no groove																				
Han E®, Crimp contact, Contact surface: Gold plated 	0,14 ... 0,37	09 33 000 6117	09 33 000 6217																		
	0,5	09 33 000 6122	09 33 000 6222																		
	0,75	09 33 000 6115	09 33 000 6215																		
	1	09 33 000 6118	09 33 000 6218																		
	1,5	09 33 000 6116	09 33 000 6216																		
	2,5	09 33 000 6123	09 33 000 6223																		
	3	09 33 000 6119	09 33 000 6219																		
	4	09 33 000 6119	09 33 000 6221																		
		<table border="1"> <thead> <tr> <th>Conductor cross-section</th> <th>Identification</th> </tr> </thead> <tbody> <tr> <td>0.14-0.37 mm<sup>2</sup></td> <td>AWG 26-22 no groove</td> </tr> <tr> <td>0.5 mm<sup>2</sup></td> <td>AWG 20 no groove</td> </tr> <tr> <td>0.75 mm<sup>2</sup></td> <td>AWG 18 1 groove*</td> </tr> <tr> <td>1 mm<sup>2</sup></td> <td>AWG 18 1 groove</td> </tr> <tr> <td>1.5 mm<sup>2</sup></td> <td>AWG 16 2 grooves</td> </tr> <tr> <td>2.5 mm<sup>2</sup></td> <td>AWG 14 3 grooves</td> </tr> <tr> <td>3 mm<sup>2</sup></td> <td>AWG 12 wide groove</td> </tr> <tr> <td>4 mm<sup>2</sup></td> <td>AWG 12 no groove</td> </tr> </tbody> </table> * on the back crimp collar Stripping length 7.5 mm		Conductor cross-section	Identification	0.14-0.37 mm <sup>2</sup>	AWG 26-22 no groove	0.5 mm <sup>2</sup>	AWG 20 no groove	0.75 mm <sup>2</sup>	AWG 18 1 groove*	1 mm <sup>2</sup>	AWG 18 1 groove	1.5 mm <sup>2</sup>	AWG 16 2 grooves	2.5 mm <sup>2</sup>	AWG 14 3 grooves	3 mm <sup>2</sup>	AWG 12 wide groove	4 mm <sup>2</sup>	AWG 12 no groove
Conductor cross-section	Identification																				
0.14-0.37 mm <sup>2</sup>	AWG 26-22 no groove																				
0.5 mm <sup>2</sup>	AWG 20 no groove																				
0.75 mm <sup>2</sup>	AWG 18 1 groove*																				
1 mm <sup>2</sup>	AWG 18 1 groove																				
1.5 mm <sup>2</sup>	AWG 16 2 grooves																				
2.5 mm <sup>2</sup>	AWG 14 3 grooves																				
3 mm <sup>2</sup>	AWG 12 wide groove																				
4 mm <sup>2</sup>	AWG 12 no groove																				

## Features

- Suitable for Han E® crimp contacts
- Higher density of crimping contacts
- Standard module for power up to 16 A
- Also suitable as a reliable signal connector

## Technical characteristics

Number of contacts	20
Electrical data acc. to IEC 61984	16 A 500 V 6 kV 3
Rated current	16 A
Rated voltage	500 V
Rated impulse voltage	6 kV
Pollution degree	3
Rated voltage acc. to UL	600 V
Insulation resistance	$\geq 10^{10} \Omega$
Contact resistance	$\leq 1 \text{ m}\Omega$
Limiting temperature	-40 ... +125 °C
Flammability acc. to UL 94	V-0
Mating cycles	$\geq 500$
Mating cycles with other HMC components	$\geq 10000$
Material (insert)	Polycarbonate
Colour (insert)	RAL 7032 (pebble grey)
Material (contacts)	Copper alloy

Modular

## Derating

### Current carrying capacity

The current carrying capacity of the connectors is limited by the thermal load capability of the contact element material including the connections and the insulating parts. The derating curve is therefore valid for currents which flow constantly (non-intermittent) through each contact element of the connector evenly, without exceeding the allowed maximum temperature.

Measuring and testing techniques acc. to IEC 60512-5-2

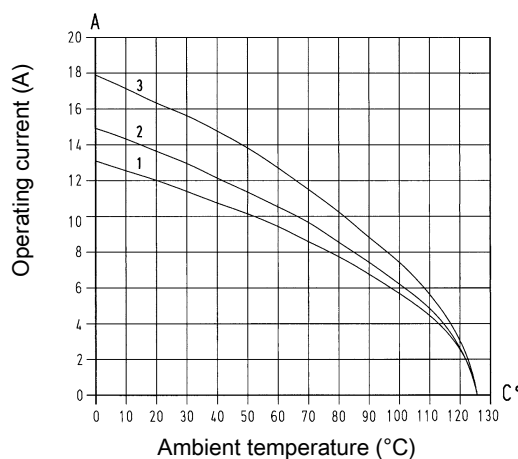

- ① 24 B hoods/housings with 3 modules Conductor cross-section 1.5 mm<sup>2</sup>
- ② 24 B hoods/housings with 3 modules Conductor cross-section 2.5 mm<sup>2</sup>
- ③ 24 B hoods/housings with 3 modules Conductor cross-section 4 mm<sup>2</sup>

## Specifications and approvals

EN 60664-1  
IEC 61984  
UL 1977 ECBT2.E235076



## Details

**Crimping tools** see chapter 90



### Remarks on the crimp technique

The wire gauges mentioned in the catalogue refer to geometric wire gauges of cables.

Number of contacts

# 20

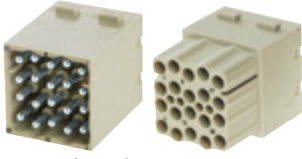
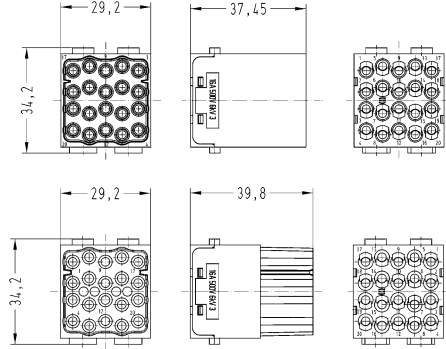
16 A 500 V 6 kV 3

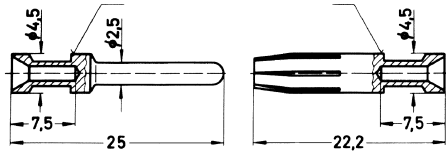
Identification	Conductor cross-section (mm <sup>2</sup> )	Part number		Drawing (dimensions in mm)																											
		Male	Female																												
Han-Modular®, Han® EEE module, Crimp termination  <p>Please order crimp contacts separately.</p>	0,14 ... 4	09 14 020 3001	09 14 020 3101	 <p>Contact arrangement (view from termination side)</p>																											
Han E®, Crimp contact, Contact surface: Silver plated 	0,14 ... 0,37 0,5 0,75 1 1,5 2,5 3 4	09 33 000 6127 09 33 000 6121 09 33 000 6114 09 33 000 6105 09 33 000 6104 09 33 000 6102 09 33 000 6106 09 33 000 6107	09 33 000 6227 09 33 000 6220 09 33 000 6214 09 33 000 6205 09 33 000 6204 09 33 000 6202 09 33 000 6206 09 33 000 6207	 <table border="1" data-bbox="997 1310 1444 1590"> <thead> <tr> <th colspan="2">Conductor cross-section</th> <th>Identification</th> </tr> </thead> <tbody> <tr> <td>0.14-0.37 mm<sup>2</sup></td> <td>AWG 26-22</td> <td>no groove</td> </tr> <tr> <td>0.5 mm<sup>2</sup></td> <td>AWG 20</td> <td>no groove</td> </tr> <tr> <td>0.75 mm<sup>2</sup></td> <td>AWG 18</td> <td>1 groove*</td> </tr> <tr> <td>1 mm<sup>2</sup></td> <td>AWG 18</td> <td>1 groove</td> </tr> <tr> <td>1.5 mm<sup>2</sup></td> <td>AWG 16</td> <td>2 grooves</td> </tr> <tr> <td>2.5 mm<sup>2</sup></td> <td>AWG 14</td> <td>3 grooves</td> </tr> <tr> <td>3 mm<sup>2</sup></td> <td>AWG 12</td> <td>wide groove</td> </tr> <tr> <td>4 mm<sup>2</sup></td> <td>AWG 12</td> <td>no groove</td> </tr> </tbody> </table> <p>* on the back crimp collar</p> <p>Stripping length 7.5 mm</p>	Conductor cross-section		Identification	0.14-0.37 mm <sup>2</sup>	AWG 26-22	no groove	0.5 mm <sup>2</sup>	AWG 20	no groove	0.75 mm <sup>2</sup>	AWG 18	1 groove*	1 mm <sup>2</sup>	AWG 18	1 groove	1.5 mm <sup>2</sup>	AWG 16	2 grooves	2.5 mm <sup>2</sup>	AWG 14	3 grooves	3 mm <sup>2</sup>	AWG 12	wide groove	4 mm <sup>2</sup>	AWG 12	no groove
Conductor cross-section		Identification																													
0.14-0.37 mm <sup>2</sup>	AWG 26-22	no groove																													
0.5 mm <sup>2</sup>	AWG 20	no groove																													
0.75 mm <sup>2</sup>	AWG 18	1 groove*																													
1 mm <sup>2</sup>	AWG 18	1 groove																													
1.5 mm <sup>2</sup>	AWG 16	2 grooves																													
2.5 mm <sup>2</sup>	AWG 14	3 grooves																													
3 mm <sup>2</sup>	AWG 12	wide groove																													
4 mm <sup>2</sup>	AWG 12	no groove																													

Modular

Identification	Conductor cross-section (mm <sup>2</sup> )	Part number		Drawing (dimensions in mm)
		Male	Female	
Han E®, Crimp contact, Contact surface: Gold plated	0,14 ... 0,37	09 33 000 6117	09 33 000 6217	
	0,5	09 33 000 6122	09 33 000 6222	
	0,75	09 33 000 6115	09 33 000 6215	
	1	09 33 000 6118	09 33 000 6218	
	1,5	09 33 000 6116	09 33 000 6216	
	2,5	09 33 000 6123	09 33 000 6223	
	4	09 33 000 6119	09 33 000 6221	

Conductor cross-section	AWG	Identification
0.14-0.37 mm <sup>2</sup>	AWG 26-22	no groove
0.5 mm <sup>2</sup>	AWG 20	no groove
0.75 mm <sup>2</sup>	AWG 18	1 groove*
1 mm <sup>2</sup>	AWG 18	1 groove
1.5 mm <sup>2</sup>	AWG 16	2 grooves
2.5 mm <sup>2</sup>	AWG 14	3 grooves
3 mm <sup>2</sup>	AWG 12	wide groove
4 mm <sup>2</sup>	AWG 12	no groove

\* on the back crimp collar

Stripping length 7.5 mm

Modular



## Features

- Reliable cage clamp termination
- No special tools required

## Technical characteristics

Number of contacts	5
Electrical data acc. to IEC 61984	16 A 400 V 6 kV 3
Rated current	16 A
Rated voltage	400 V
Rated impulse voltage	6 kV
Pollution degree	3
Rated voltage acc. to UL	600 V
Insulation resistance	$\geq 10^{10} \Omega$
Contact resistance	$\leq 3 \text{ m}\Omega$
Limiting temperature	-40 ... +125 °C
Flammability acc. to UL 94	V-0
Mating cycles	$\geq 500$
Material (insert)	Polycarbonate
Colour (insert)	RAL 7032 (pebble grey)
Material (contacts)	Copper alloy

## Derating

### Current carrying capacity

The current carrying capacity of the connectors is limited by the thermal load capability of the contact element material including the connections and the insulating parts. The derating curve is therefore valid for currents which flow constantly (non-intermittent) through each contact element of the connector evenly, without exceeding the allowed maximum temperature.

Measuring and testing techniques acc. to IEC 60512-5-2

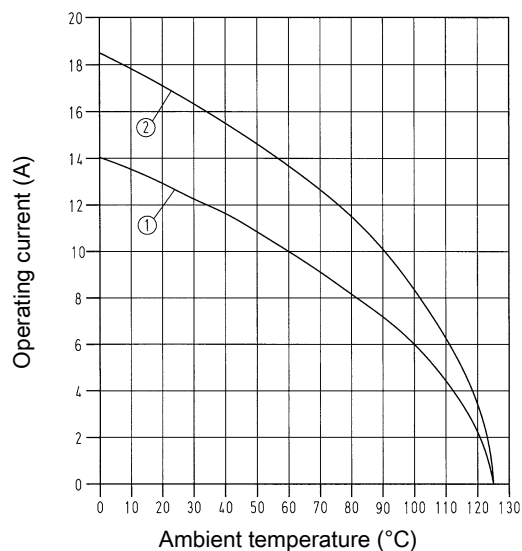

- ① 24 B hoods/housings with 6 modules Conductor cross-section 1.5 mm<sup>2</sup>  
 ② 24 B hoods/housings with 6 modules Conductor cross-section 2.5 mm<sup>2</sup>

## Specifications and approvals

EN 60664-1  
 IEC 61984  
 UL 1977 ECBT2.E235076



Number of contacts

# 5

16 A 400 V 6 kV 3

Modular

Identification	Conductor cross-section (mm <sup>2</sup> )	Part number		Drawing (dimensions in mm)
		Male	Female	
Han-Modular®, Han® ES module, Cage-clamp termination, Contact surface: Silver plated	0,14 ... 2,5	09 14 005 2616	09 14 005 2716	
Han-Modular®, Han® ES module, Cage-clamp termination, Contact surface: Gold plated	0,14 ... 2,5	09 14 005 2617	09 14 005 2717	<p>Contact arrangement (view from termination side)</p>

## Features

- Available in two versions: for Han® C or Han E® crimp contacts
- 2 contacts up to 5000 V
- Insulator out of a voltage resistant teflon material
- Combination with all other modules (pneumatic, signal etc.)

## Technical characteristics

Number of contacts	2
Electrical data acc. to IEC 61984	40 A 2.900/5.000 V 15 kV 3, 16 A 2.900/5.000 V 15 kV 3
Rated current	40 A, 16 A
Rated voltage conductor-earth	2900 V
Rated voltage conductor-conductor	5000 V
Rated impulse voltage	15 kV
Pollution degree	3
Rated voltage acc. to UL	5000 V
Insulation resistance	≥10 <sup>10</sup> Ω
Contact resistance	≤1 mΩ
Limiting temperature	-40 ... +125 °C
Flammability acc. to UL 94	V-0
Mating cycles	≥500
Material (insert)	Polycarbonate / Teflon (PTFE)
Colour (insert)	RAL 7032 (pebble grey)
Material (contacts)	Copper alloy

## Derating

### Current carrying capacity

The current carrying capacity of the connectors is limited by the thermal load capability of the contact element material including the connections and the insulating parts. The derating curve is therefore valid for currents which flow constantly (non-intermittent) through each contact element of the connector evenly, without exceeding the allowed maximum temperature.

Measuring and testing techniques acc. to IEC 60512-5-2

Han® C crimp contacts

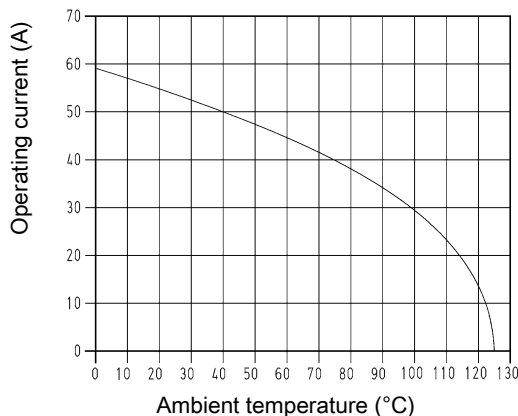

① 24 B hoods/housings with 3 modules Conductor cross-section 6 mm<sup>2</sup>

## Derating

Han E® crimp contacts

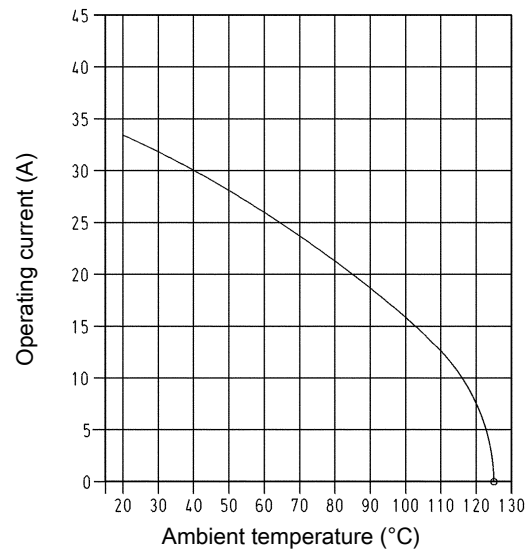

① Housing Han® 16 B with 1 Han® HV module Conductor cross-section 2.5 mm<sup>2</sup>

## Specifications and approvals

EN 60664-1  
IEC 61984  
EN 50124-1  
IEC 60352-4  
UL 1977 ECBT2.E235076



## Details

**Crimping tools** see chapter 90

### Remarks on the crimp technique



The wire gauges mentioned in the catalogue refer to geometric wire gauges of cables.

Number of contacts

# 2

40 A 2.900/5.000 V 15 kV 3

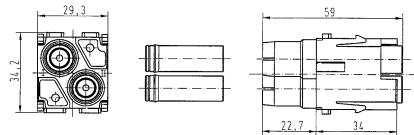
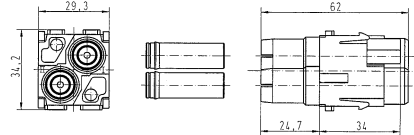
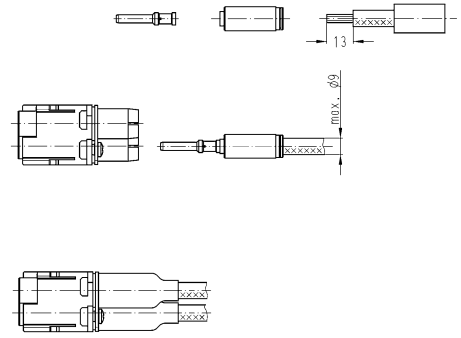

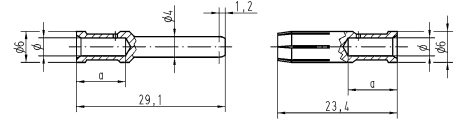
Modular

Identification	Conductor cross-section (mm <sup>2</sup> )	Part number		Drawing (dimensions in mm)																		
		Male	Female																			
<p>Han-Modular®, Han® HV module, for Han® C crimp contacts, Crimp termination, Crimp termination,</p> <p>Pack contents: 1 module, 2 locking sleeves, 2 heat shrink tubes</p>  <p>Please order crimp contacts separately.</p>	1,5 ... 10	09 14 002 3023	09 14 002 3123	<p>M</p>  <p>F</p>  <p>Assembly instructions</p>  <p>ATTENTION! Stripping length 13 mm Crimp with tool 09 99 000 0888, 09 99 000 0110 or 09 99 000 0377 Snap crimped cable in the insert. Shrink the heat shrink tube over the rear of contact.</p>																		
<p>Han® C, Crimp contact, Contact surface: Silver plated</p> 	1,5 2,5 4 6 10	09 32 000 6104 09 32 000 6105 09 32 000 6107 09 32 000 6108 09 32 000 6109	09 32 000 6204 09 32 000 6205 09 32 000 6207 09 32 000 6208 09 32 000 6209	 <table border="1"> <thead> <tr> <th>Conductor cross-section</th> <th>Ø</th> <th>Stripping length</th> </tr> </thead> <tbody> <tr> <td>1.5 mm<sup>2</sup> AWG 16</td> <td>1.75 mm</td> <td>9.5 mm</td> </tr> <tr> <td>2.5 mm<sup>2</sup> AWG 14</td> <td>2.25 mm</td> <td>9.5 mm</td> </tr> <tr> <td>4 mm<sup>2</sup> AWG 12</td> <td>2.85 mm</td> <td>9.5 mm</td> </tr> <tr> <td>6 mm<sup>2</sup> AWG 10</td> <td>3.5 mm</td> <td>9.5 mm</td> </tr> <tr> <td>10 mm<sup>2</sup> AWG 8</td> <td>4.3 mm</td> <td>12 mm</td> </tr> </tbody> </table>	Conductor cross-section	Ø	Stripping length	1.5 mm <sup>2</sup> AWG 16	1.75 mm	9.5 mm	2.5 mm <sup>2</sup> AWG 14	2.25 mm	9.5 mm	4 mm <sup>2</sup> AWG 12	2.85 mm	9.5 mm	6 mm <sup>2</sup> AWG 10	3.5 mm	9.5 mm	10 mm <sup>2</sup> AWG 8	4.3 mm	12 mm
Conductor cross-section	Ø	Stripping length																				
1.5 mm <sup>2</sup> AWG 16	1.75 mm	9.5 mm																				
2.5 mm <sup>2</sup> AWG 14	2.25 mm	9.5 mm																				
4 mm <sup>2</sup> AWG 12	2.85 mm	9.5 mm																				
6 mm <sup>2</sup> AWG 10	3.5 mm	9.5 mm																				
10 mm <sup>2</sup> AWG 8	4.3 mm	12 mm																				

Number of contacts

# 2

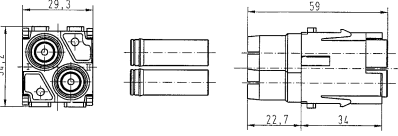
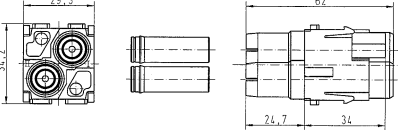
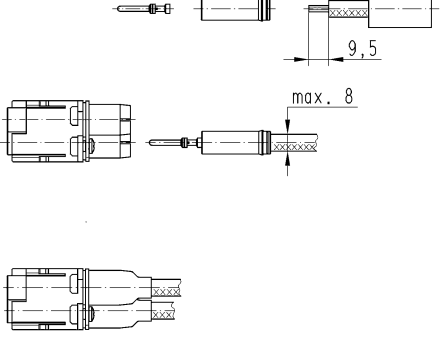
16 A 2.900/5.000 V 15 kV 3

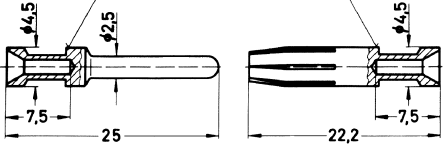
Identification	Conductor cross-section (mm <sup>2</sup> )	Part number		Drawing (dimensions in mm)																		
		Male	Female																			
<p>Han-Modular®, Han® HV module, for Han E® crimp contacts, Crimp termination,</p> <p>Pack contents: 1 module, 2 locking sleeves, 2 heat shrink tubes</p>  <p>Please order crimp contacts separately.</p>	0,5 ... 4	09 14 002 3021	09 14 002 3121	<p>M</p>  <p>F</p>  <p>Assembly instructions</p>  <p>ATTENTION! Stripping length 9.5 mm Crimp with crimping tool 09 99 000 0888 Snap crimped cable in the insert. Shrink the heat shrink tube over the rear of contact.</p>																		
<p>Han E®, Crimp contact, Contact surface: Silver plated</p> 	0,5 0,75 1 1,5 2,5 3 4	09 33 000 6121 09 33 000 6114 09 33 000 6105 09 33 000 6104 09 33 000 6102 09 33 000 6106 09 33 000 6107	09 33 000 6220 09 33 000 6214 09 33 000 6205 09 33 000 6204 09 33 000 6202 09 33 000 6206 09 33 000 6207	 <table border="1"> <thead> <tr> <th>Conductor cross-section</th> <th>Identification</th> </tr> </thead> <tbody> <tr> <td>0.14-0.37 mm<sup>2</sup></td> <td>AWG 26-22 no groove</td> </tr> <tr> <td>0.5 mm<sup>2</sup></td> <td>AWG 20 no groove</td> </tr> <tr> <td>0.75 mm<sup>2</sup></td> <td>AWG 18 1 groove*</td> </tr> <tr> <td>1 mm<sup>2</sup></td> <td>AWG 18 1 groove</td> </tr> <tr> <td>1.5 mm<sup>2</sup></td> <td>AWG 16 2 grooves</td> </tr> <tr> <td>2.5 mm<sup>2</sup></td> <td>AWG 14 3 grooves</td> </tr> <tr> <td>3 mm<sup>2</sup></td> <td>AWG 12 wide groove</td> </tr> <tr> <td>4 mm<sup>2</sup></td> <td>AWG 12 no groove</td> </tr> </tbody> </table> <p>* on the back crimp collar</p> <p>Stripping length 7.5 mm</p>	Conductor cross-section	Identification	0.14-0.37 mm <sup>2</sup>	AWG 26-22 no groove	0.5 mm <sup>2</sup>	AWG 20 no groove	0.75 mm <sup>2</sup>	AWG 18 1 groove*	1 mm <sup>2</sup>	AWG 18 1 groove	1.5 mm <sup>2</sup>	AWG 16 2 grooves	2.5 mm <sup>2</sup>	AWG 14 3 grooves	3 mm <sup>2</sup>	AWG 12 wide groove	4 mm <sup>2</sup>	AWG 12 no groove
Conductor cross-section	Identification																					
0.14-0.37 mm <sup>2</sup>	AWG 26-22 no groove																					
0.5 mm <sup>2</sup>	AWG 20 no groove																					
0.75 mm <sup>2</sup>	AWG 18 1 groove*																					
1 mm <sup>2</sup>	AWG 18 1 groove																					
1.5 mm <sup>2</sup>	AWG 16 2 grooves																					
2.5 mm <sup>2</sup>	AWG 14 3 grooves																					
3 mm <sup>2</sup>	AWG 12 wide groove																					
4 mm <sup>2</sup>	AWG 12 no groove																					

Modular

## Features

- Suitable for Han E® crimp contacts
- 2 contacts up to 2500 V
- Insulator out of a voltage resistant teflon material
- Combination with all other modules (pneumatic, signal etc.)

## Technical characteristics

Number of contacts	2
Electrical data acc. to IEC 61984	16 A 2.500 V 15 kV 3
Rated current	16 A
Rated voltage	2500 V
Rated impulse voltage	15 kV
Pollution degree	3
Insulation resistance	$\geq 10^{10} \Omega$
Contact resistance	$\leq 1 \text{ m}\Omega$
Limiting temperature	-40 ... +125 °C
Flammability acc. to UL 94	V-0
Mating cycles	$\geq 500$
Material (insert)	Polycarbonate / Teflon (PTFE)
Colour (insert)	RAL 7032 (pebble grey)
Material (contacts)	Copper alloy

Modular

## Derating

### Current carrying capacity

The current carrying capacity of the connectors is limited by the thermal load capability of the contact element material including the connections and the insulating parts. The derating curve is therefore valid for currents which flow constantly (non-intermittent) through each contact element of the connector evenly, without exceeding the allowed maximum temperature.

Measuring and testing techniques acc. to IEC 60512-5-2

#### Han E® crimp contacts

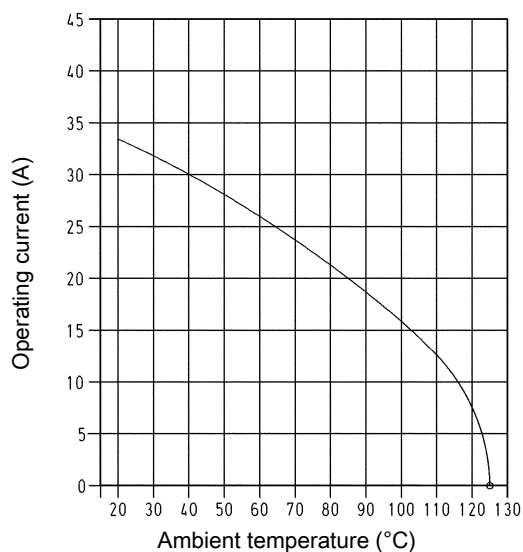

① Housing Han® 16 B with 1 Han® HV module Conductor cross-section 2.5 mm<sup>2</sup>

## Specifications and approvals

EN 60664-1  
IEC 61984  
EN 50124-1



## Details

**Crimping tools** see chapter 90



### Remarks on the crimp technique

The wire gauges mentioned in the catalogue refer to geometric wire gauges of cables.

Number of contacts

# 2

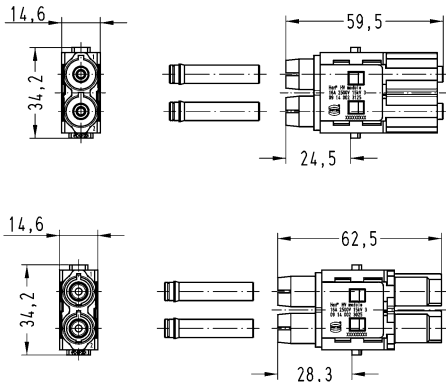
16 A 2.500 V 15 kV 3

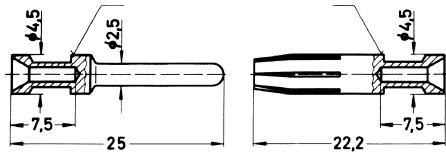
Identification	Conductor cross-section (mm <sup>2</sup> )	Part number		Drawing (dimensions in mm)																											
		Male	Female																												
Han-Modular®, Han® HV module, Single module, Crimp termination, Pack contents: 1 module, 2 locking sleeves, 2 heat shrink tubes  <p>Please order crimp contacts separately.</p>	0,5 ... 4	09 14 002 3025	09 14 002 3125																												
Han E®, Crimp contact, Contact surface: Silver plated 	0,5 0,75 1 1,5 2,5 3 4	09 33 000 6121 09 33 000 6114 09 33 000 6105 09 33 000 6104 09 33 000 6102 09 33 000 6106 09 33 000 6107	09 33 000 6220 09 33 000 6214 09 33 000 6205 09 33 000 6204 09 33 000 6202 09 33 000 6206 09 33 000 6207	 <table border="1" data-bbox="997 1232 1444 1512"> <thead> <tr> <th>Conductor cross-section</th> <th>AWG</th> <th>Identification</th> </tr> </thead> <tbody> <tr> <td>0.14-0.37 mm<sup>2</sup></td> <td>AWG 26-22</td> <td>no groove</td> </tr> <tr> <td>0.5 mm<sup>2</sup></td> <td>AWG 20</td> <td>no groove</td> </tr> <tr> <td>0.75 mm<sup>2</sup></td> <td>AWG 18</td> <td>1 groove*</td> </tr> <tr> <td>1 mm<sup>2</sup></td> <td>AWG 18</td> <td>1 groove</td> </tr> <tr> <td>1.5 mm<sup>2</sup></td> <td>AWG 16</td> <td>2 grooves</td> </tr> <tr> <td>2.5 mm<sup>2</sup></td> <td>AWG 14</td> <td>3 grooves</td> </tr> <tr> <td>3 mm<sup>2</sup></td> <td>AWG 12</td> <td>wide groove</td> </tr> <tr> <td>4 mm<sup>2</sup></td> <td>AWG 12</td> <td>no groove</td> </tr> </tbody> </table> <p>* on the back crimp collar                      Stripping length 7.5 mm</p>	Conductor cross-section	AWG	Identification	0.14-0.37 mm <sup>2</sup>	AWG 26-22	no groove	0.5 mm <sup>2</sup>	AWG 20	no groove	0.75 mm <sup>2</sup>	AWG 18	1 groove*	1 mm <sup>2</sup>	AWG 18	1 groove	1.5 mm <sup>2</sup>	AWG 16	2 grooves	2.5 mm <sup>2</sup>	AWG 14	3 grooves	3 mm <sup>2</sup>	AWG 12	wide groove	4 mm <sup>2</sup>	AWG 12	no groove
Conductor cross-section	AWG	Identification																													
0.14-0.37 mm <sup>2</sup>	AWG 26-22	no groove																													
0.5 mm <sup>2</sup>	AWG 20	no groove																													
0.75 mm <sup>2</sup>	AWG 18	1 groove*																													
1 mm <sup>2</sup>	AWG 18	1 groove																													
1.5 mm <sup>2</sup>	AWG 16	2 grooves																													
2.5 mm <sup>2</sup>	AWG 14	3 grooves																													
3 mm <sup>2</sup>	AWG 12	wide groove																													
4 mm <sup>2</sup>	AWG 12	no groove																													

Modular

## Features

- Han-Quick Lock<sup>®</sup> or crimp termination available
- Standard module for signal up to 10 A

## Technical characteristics

Number of contacts	12
Electrical data acc. to IEC 61984	10 A 250 V 4 kV 3
Rated current	10 A
Rated voltage	250 V
Rated impulse voltage	4 kV
Pollution degree	3
Rated voltage acc. to UL	600 V
Insulation resistance	≥10 <sup>10</sup> Ω
Contact resistance	≤3 mΩ
Limiting temperature	-40 ... +125 °C
Flammability acc. to UL 94	V-0
Mating cycles	≥500
Mating cycles with other HMC components	≥10000
Material (insert)	Polycarbonate
Colour (insert)	RAL 7032 (pebble grey)
Material (contacts)	Copper alloy

## Derating

### Current carrying capacity

The current carrying capacity of the connectors is limited by the thermal load capability of the contact element material including the connections and the insulating parts. The derating curve is therefore valid for currents which flow constantly (non-intermittent) through each contact element of the connector evenly, without exceeding the allowed maximum temperature.

Measuring and testing techniques acc. to IEC 60512-5-2

Han-Quick Lock<sup>®</sup> termination

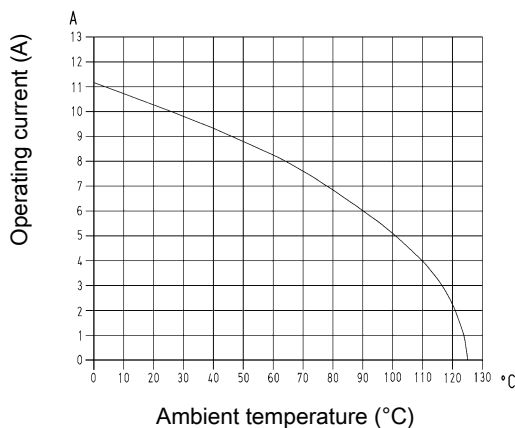

① 24 B hoods/housings with 6 modules Conductor cross-section 1.5 mm<sup>2</sup>

## Derating

Crimp termination

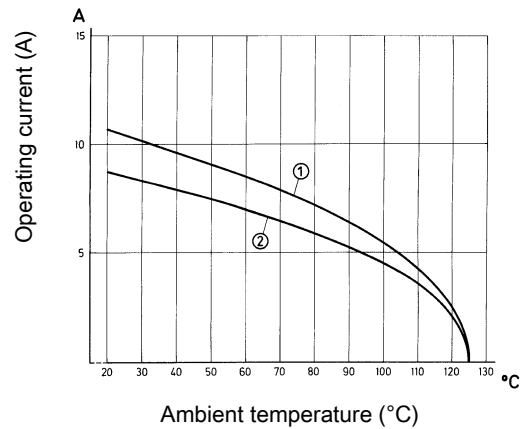

① 24 B hoods/housings with 6 modules Conductor cross-section 1.5 mm<sup>2</sup>

② 24 B hoods/housings with 6 modules Conductor cross-section 1 mm<sup>2</sup>

## Specifications and approvals

EN 60664-1  
IEC 61984  
UL 1977 ECBT2.E235076



## Details

**Crimping tools** see chapter 90

### Remarks on the crimp technique

The wire gauges mentioned in the catalogue refer to geometric wire gauges of cables.



Number of contacts



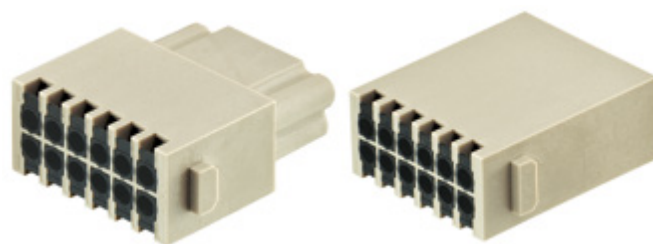

# 12

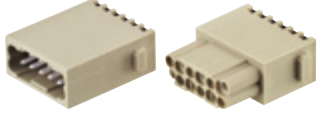
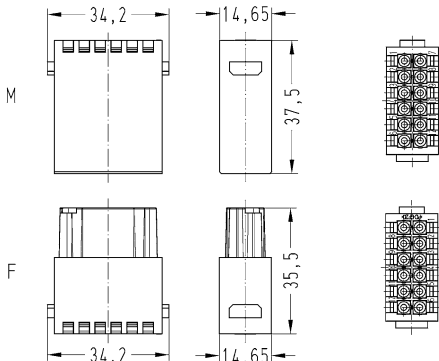
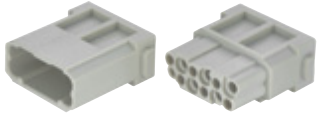
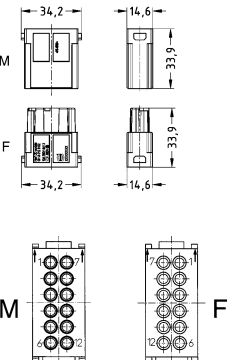
10 A 250 V 4 kV 3

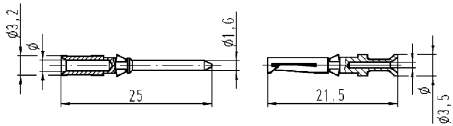

Identification	Conductor cross-section (mm <sup>2</sup> )	Part number		Drawing (dimensions in mm)
		Male	Female	
<p>Han-Modular®, Han DD® module, Han-Quick Lock® termination, Contact surface: Silver plated</p>  <p>Black slide</p>	0,25 ... 1,5	09 14 012 2632	09 14 012 2732	 <p>Contact arrangement (view from termination side) Stripping length 10 mm</p>
<p>Han-Modular®, Han DD® module, Han-Quick Lock® termination, Contact surface: Gold plated Black slide</p>	0,25 ... 1,5	09 14 012 2634	09 14 012 2734	
<p>Han-Modular®, Han DD® module, Crimp termination</p>  <p>Please order crimp contacts separately.</p>	0,14 ... 2,5	09 14 012 3002	09 14 012 3102	 <p>Contact arrangement (view from termination side)</p>

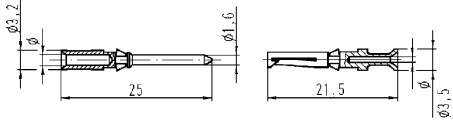
Modular

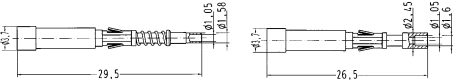
Identification	Conductor cross-section (mm <sup>2</sup> )	Part number		Drawing (dimensions in mm)																					
		Male	Female																						
Han D®, Crimp contact, Contact surface: Silver plated 	0,14 ... 0,37	09 15 000 6104	09 15 000 6204	 <table border="1" data-bbox="965 504 1420 660"> <thead> <tr> <th>Wire gauge</th> <th>∅</th> <th>Stripping length</th> </tr> </thead> <tbody> <tr> <td>0.14-0.37 mm<sup>2</sup> AWG 26-22</td> <td>0.9 mm</td> <td>8 mm</td> </tr> <tr> <td>0.5 mm<sup>2</sup> AWG 20</td> <td>1.1 mm</td> <td>8 mm</td> </tr> <tr> <td>0.75 mm<sup>2</sup> AWG 18</td> <td>1.3 mm</td> <td>8 mm</td> </tr> <tr> <td>1 mm<sup>2</sup> AWG 18</td> <td>1.45 mm</td> <td>8 mm</td> </tr> <tr> <td>1.5 mm<sup>2</sup> AWG 16</td> <td>1.75 mm</td> <td>8 mm</td> </tr> <tr> <td>2.5 mm<sup>2</sup> AWG 14</td> <td>2.25 mm</td> <td>6 mm</td> </tr> </tbody> </table>	Wire gauge	∅	Stripping length	0.14-0.37 mm <sup>2</sup> AWG 26-22	0.9 mm	8 mm	0.5 mm <sup>2</sup> AWG 20	1.1 mm	8 mm	0.75 mm <sup>2</sup> AWG 18	1.3 mm	8 mm	1 mm <sup>2</sup> AWG 18	1.45 mm	8 mm	1.5 mm <sup>2</sup> AWG 16	1.75 mm	8 mm	2.5 mm <sup>2</sup> AWG 14	2.25 mm	6 mm
	Wire gauge	∅	Stripping length																						
	0.14-0.37 mm <sup>2</sup> AWG 26-22	0.9 mm	8 mm																						
	0.5 mm <sup>2</sup> AWG 20	1.1 mm	8 mm																						
	0.75 mm <sup>2</sup> AWG 18	1.3 mm	8 mm																						
	1 mm <sup>2</sup> AWG 18	1.45 mm	8 mm																						
1.5 mm <sup>2</sup> AWG 16	1.75 mm	8 mm																							
2.5 mm <sup>2</sup> AWG 14	2.25 mm	6 mm																							
0,5	09 15 000 6103	09 15 000 6203																							
0,75	09 15 000 6105	09 15 000 6205																							
1	09 15 000 6102	09 15 000 6202																							
1,5	09 15 000 6101	09 15 000 6201																							
2,5	09 15 000 6106	09 15 000 6206																							
Han D®, Crimp contact, Contact surface: Gold plated 	0,14 ... 0,37	09 15 000 6124	09 15 000 6224	 <table border="1" data-bbox="965 862 1420 1019"> <thead> <tr> <th>Wire gauge</th> <th>∅</th> <th>Stripping length</th> </tr> </thead> <tbody> <tr> <td>0.14-0.37 mm<sup>2</sup> AWG 26-22</td> <td>0.9 mm</td> <td>8 mm</td> </tr> <tr> <td>0.5 mm<sup>2</sup> AWG 20</td> <td>1.1 mm</td> <td>8 mm</td> </tr> <tr> <td>0.75 mm<sup>2</sup> AWG 18</td> <td>1.3 mm</td> <td>8 mm</td> </tr> <tr> <td>1 mm<sup>2</sup> AWG 18</td> <td>1.45 mm</td> <td>8 mm</td> </tr> <tr> <td>1.5 mm<sup>2</sup> AWG 16</td> <td>1.75 mm</td> <td>8 mm</td> </tr> <tr> <td>2.5 mm<sup>2</sup> AWG 14</td> <td>2.25 mm</td> <td>6 mm</td> </tr> </tbody> </table>	Wire gauge	∅	Stripping length	0.14-0.37 mm <sup>2</sup> AWG 26-22	0.9 mm	8 mm	0.5 mm <sup>2</sup> AWG 20	1.1 mm	8 mm	0.75 mm <sup>2</sup> AWG 18	1.3 mm	8 mm	1 mm <sup>2</sup> AWG 18	1.45 mm	8 mm	1.5 mm <sup>2</sup> AWG 16	1.75 mm	8 mm	2.5 mm <sup>2</sup> AWG 14	2.25 mm	6 mm
	Wire gauge	∅	Stripping length																						
	0.14-0.37 mm <sup>2</sup> AWG 26-22	0.9 mm	8 mm																						
	0.5 mm <sup>2</sup> AWG 20	1.1 mm	8 mm																						
	0.75 mm <sup>2</sup> AWG 18	1.3 mm	8 mm																						
	1 mm <sup>2</sup> AWG 18	1.45 mm	8 mm																						
1.5 mm <sup>2</sup> AWG 16	1.75 mm	8 mm																							
2.5 mm <sup>2</sup> AWG 14	2.25 mm	6 mm																							
0,5	09 15 000 6123	09 15 000 6223																							
0,75	09 15 000 6125	09 15 000 6225																							
1	09 15 000 6122	09 15 000 6222																							
1,5	09 15 000 6121	09 15 000 6221																							
2,5	09 15 000 6126	09 15 000 6226																							
FO contact, for 1 mm plastic fibre 		20 10 001 3211	20 10 001 3221	 <p>20 10 001 3211 + 20 10 001 3221</p>																					

Modular

## Technical characteristics

Number of contacts	42
Electrical data acc. to IEC 61984	10 A 150 V 2,5 kV 3
Rated current	10 A
Rated voltage	150 V
Rated impulse voltage	2.5 kV
Pollution degree	3
Rated voltage acc. to UL	250 V
Insulation resistance	$\geq 10^{10} \Omega$
Contact resistance	$\leq 3 \text{ m}\Omega$
Limiting temperature	-40 ... +125 °C
Flammability acc. to UL 94	V-0
Mating cycles	$\geq 500$
Material (insert)	LCP
Material (contacts)	Copper alloy

## Derating

### Current carrying capacity

The current carrying capacity of the connectors is limited by the thermal load capability of the contact element material including the connections and the insulating parts. The derating curve is therefore valid for currents which flow constantly (non-intermittent) through each contact element of the connector evenly, without exceeding the allowed maximum temperature.

Measuring and testing techniques acc. to IEC 60512-5-2

Crimp termination

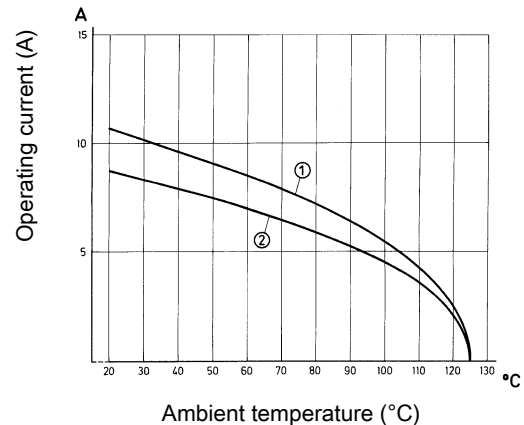

① 24 B hoods/housings with 6 modules Conductor cross-section 1.5 mm<sup>2</sup>

② 24 B hoods/housings with 6 modules Conductor cross-section 1 mm<sup>2</sup>

## Specifications and approvals

UL 1977 ECBT2.E235076  
 EN 60664-1  
 IEC 61984

## Details

**Crimping tools** see chapter 90

### Remarks on the crimp technique







The wire gauges mentioned in the catalogue refer to geometric wire gauges of cables.

Number of contacts

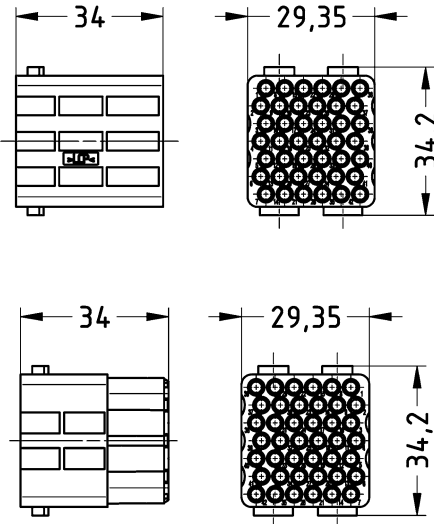
# 42

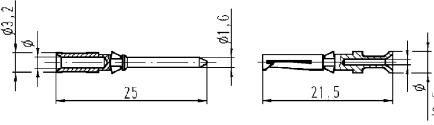
10 A 150 V 2,5 kV 3

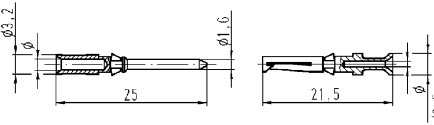
Modular

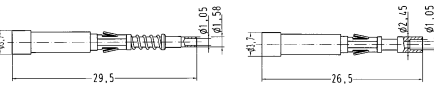
Identification	Conductor cross-section (mm <sup>2</sup> )	Part number		Drawing (dimensions in mm)																					
		Male	Female																						
Han-Modular®, Han DD® Quad Module, Crimp termination  <p>Please order crimp contacts separately.</p>	0,14 ... 2,5	09 14 042 3001	09 14 042 3101																						
Han D®, Crimp contact, Contact surface: Silver plated 	0,14 ... 0,37 0,14 ... 0,37 0,5 0,75 1 1,5 2,5	09 15 000 6104 09 15 000 6107 09 15 000 6103 09 15 000 6105 09 15 000 6102 09 15 000 6101 09 15 000 6106	09 15 000 6204 09 15 000 6207 09 15 000 6203 09 15 000 6205 09 15 000 6202 09 15 000 6201 09 15 000 6206	 <table border="1"> <thead> <tr> <th>Wire gauge</th> <th>∅</th> <th>Stripping length</th> </tr> </thead> <tbody> <tr> <td>0.14-0.37 mm<sup>2</sup> AWG 26-22</td> <td>0.9 mm</td> <td>8 mm</td> </tr> <tr> <td>0.5 mm<sup>2</sup> AWG 20</td> <td>1.1 mm</td> <td>8 mm</td> </tr> <tr> <td>0.75 mm<sup>2</sup> AWG 18</td> <td>1.3 mm</td> <td>8 mm</td> </tr> <tr> <td>1 mm<sup>2</sup> AWG 18</td> <td>1.45 mm</td> <td>8 mm</td> </tr> <tr> <td>1.5 mm<sup>2</sup> AWG 16</td> <td>1.75 mm</td> <td>8 mm</td> </tr> <tr> <td>2.5 mm<sup>2</sup> AWG 14</td> <td>2.25 mm</td> <td>6 mm</td> </tr> </tbody> </table>	Wire gauge	∅	Stripping length	0.14-0.37 mm <sup>2</sup> AWG 26-22	0.9 mm	8 mm	0.5 mm <sup>2</sup> AWG 20	1.1 mm	8 mm	0.75 mm <sup>2</sup> AWG 18	1.3 mm	8 mm	1 mm <sup>2</sup> AWG 18	1.45 mm	8 mm	1.5 mm <sup>2</sup> AWG 16	1.75 mm	8 mm	2.5 mm <sup>2</sup> AWG 14	2.25 mm	6 mm
Wire gauge	∅	Stripping length																							
0.14-0.37 mm <sup>2</sup> AWG 26-22	0.9 mm	8 mm																							
0.5 mm <sup>2</sup> AWG 20	1.1 mm	8 mm																							
0.75 mm <sup>2</sup> AWG 18	1.3 mm	8 mm																							
1 mm <sup>2</sup> AWG 18	1.45 mm	8 mm																							
1.5 mm <sup>2</sup> AWG 16	1.75 mm	8 mm																							
2.5 mm <sup>2</sup> AWG 14	2.25 mm	6 mm																							
Han D®, Crimp contact, Contact surface: Gold plated 	0,14 ... 0,37 0,5 0,75 1 1,5 2,5	09 15 000 6124 09 15 000 6123 09 15 000 6125 09 15 000 6122 09 15 000 6121 09 15 000 6126	09 15 000 6224 09 15 000 6223 09 15 000 6225 09 15 000 6222 09 15 000 6221 09 15 000 6226	 <table border="1"> <thead> <tr> <th>Wire gauge</th> <th>∅</th> <th>Stripping length</th> </tr> </thead> <tbody> <tr> <td>0.14-0.37 mm<sup>2</sup> AWG 26-22</td> <td>0.9 mm</td> <td>8 mm</td> </tr> <tr> <td>0.5 mm<sup>2</sup> AWG 20</td> <td>1.1 mm</td> <td>8 mm</td> </tr> <tr> <td>0.75 mm<sup>2</sup> AWG 18</td> <td>1.3 mm</td> <td>8 mm</td> </tr> <tr> <td>1 mm<sup>2</sup> AWG 18</td> <td>1.45 mm</td> <td>8 mm</td> </tr> <tr> <td>1.5 mm<sup>2</sup> AWG 16</td> <td>1.75 mm</td> <td>8 mm</td> </tr> <tr> <td>2.5 mm<sup>2</sup> AWG 14</td> <td>2.25 mm</td> <td>6 mm</td> </tr> </tbody> </table>	Wire gauge	∅	Stripping length	0.14-0.37 mm <sup>2</sup> AWG 26-22	0.9 mm	8 mm	0.5 mm <sup>2</sup> AWG 20	1.1 mm	8 mm	0.75 mm <sup>2</sup> AWG 18	1.3 mm	8 mm	1 mm <sup>2</sup> AWG 18	1.45 mm	8 mm	1.5 mm <sup>2</sup> AWG 16	1.75 mm	8 mm	2.5 mm <sup>2</sup> AWG 14	2.25 mm	6 mm
Wire gauge	∅	Stripping length																							
0.14-0.37 mm <sup>2</sup> AWG 26-22	0.9 mm	8 mm																							
0.5 mm <sup>2</sup> AWG 20	1.1 mm	8 mm																							
0.75 mm <sup>2</sup> AWG 18	1.3 mm	8 mm																							
1 mm <sup>2</sup> AWG 18	1.45 mm	8 mm																							
1.5 mm <sup>2</sup> AWG 16	1.75 mm	8 mm																							
2.5 mm <sup>2</sup> AWG 14	2.25 mm	6 mm																							
FO contact, for 1 mm plastic fibre 		20 10 001 3211	20 10 001 3221	 <p>20 10 001 3211 + 20 10 001 3221</p>																					

## Features

- Suitable for Han D® crimp contacts
- High packing density

## Technical characteristics

Number of contacts	17
Electrical data acc. to IEC 61984	10 A 160 V 2,5 kV 3
Rated current	10 A
Rated voltage	160 V
Rated impulse voltage	2,5 kV
Pollution degree	3
Rated voltage acc. to UL	250 V
Insulation resistance	$\geq 10^{10} \Omega$
Contact resistance	$\leq 3 \text{ m}\Omega$
Limiting temperature	-40 ... +125 °C
Flammability acc. to UL 94	V-0
Mating cycles	$\geq 500$
Mating cycles with other HMC components	$\geq 10000$
Material (insert)	Polycarbonate
Colour (insert)	RAL 7032 (pebble grey)
Material (contacts)	Copper alloy

## Derating

### Current carrying capacity

The current carrying capacity of the connectors is limited by the thermal load capability of the contact element material including the connections and the insulating parts. The derating curve is therefore valid for currents which flow constantly (non-intermittent) through each contact element of the connector evenly, without exceeding the allowed maximum temperature.

Measuring and testing techniques acc. to IEC 60512-5-2

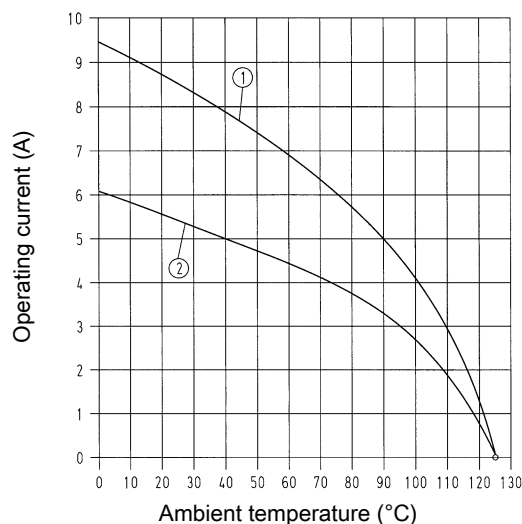

- ① 24 B hoods/housings with 6 modules Conductor cross-section 1.5 mm<sup>2</sup>  
 ② 24 B hoods/housings with 6 modules Conductor cross-section 1 mm<sup>2</sup>

## Specifications and approvals

EN 60664-1  
 IEC 61984  
 UL 1977 ECBT2.E235076



## Details

**Crimping tools** see chapter 90

### Remarks on the crimp technique







The wire gauges mentioned in the catalogue refer to geometric wire gauges of cables.

Number of contacts

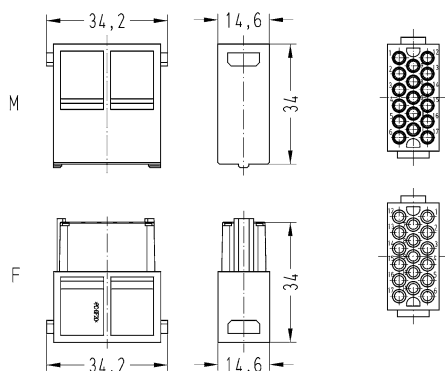
# 17

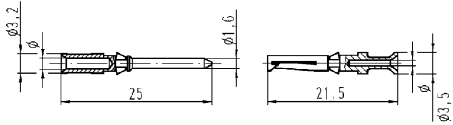
10 A 160 V 2,5 kV 3

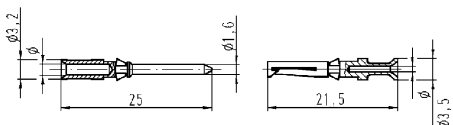
Modular

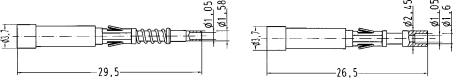
Identification	Conductor cross-section (mm <sup>2</sup> )	Part number		Drawing (dimensions in mm)																					
		Male	Female																						
Han-Modular®, Han® DDD module, Crimp termination  Please order crimp contacts separately.	0,14 ... 2,5	09 14 017 3001	09 14 017 3101	 Contact arrangement (view from termination side)																					
Han D®, Crimp contact, Contact surface: Silver plated 	0,14 ... 0,37 0,5 0,75 1 1,5 2,5	09 15 000 6104 09 15 000 6103 09 15 000 6105 09 15 000 6102 09 15 000 6101 09 15 000 6106	09 15 000 6204 09 15 000 6203 09 15 000 6205 09 15 000 6202 09 15 000 6201 09 15 000 6206	 <table border="1"> <thead> <tr> <th>Wire gauge</th> <th>∅</th> <th>Stripping length</th> </tr> </thead> <tbody> <tr> <td>0.14-0.37 mm<sup>2</sup> AWG 26-22</td> <td>0.9 mm</td> <td>8 mm</td> </tr> <tr> <td>0.5 mm<sup>2</sup> AWG 20</td> <td>1.1 mm</td> <td>8 mm</td> </tr> <tr> <td>0.75 mm<sup>2</sup> AWG 18</td> <td>1.3 mm</td> <td>8 mm</td> </tr> <tr> <td>1 mm<sup>2</sup> AWG 18</td> <td>1.45 mm</td> <td>8 mm</td> </tr> <tr> <td>1.5 mm<sup>2</sup> AWG 16</td> <td>1.75 mm</td> <td>8 mm</td> </tr> <tr> <td>2.5 mm<sup>2</sup> AWG 14</td> <td>2.25 mm</td> <td>6 mm</td> </tr> </tbody> </table>	Wire gauge	∅	Stripping length	0.14-0.37 mm <sup>2</sup> AWG 26-22	0.9 mm	8 mm	0.5 mm <sup>2</sup> AWG 20	1.1 mm	8 mm	0.75 mm <sup>2</sup> AWG 18	1.3 mm	8 mm	1 mm <sup>2</sup> AWG 18	1.45 mm	8 mm	1.5 mm <sup>2</sup> AWG 16	1.75 mm	8 mm	2.5 mm <sup>2</sup> AWG 14	2.25 mm	6 mm
Wire gauge	∅	Stripping length																							
0.14-0.37 mm <sup>2</sup> AWG 26-22	0.9 mm	8 mm																							
0.5 mm <sup>2</sup> AWG 20	1.1 mm	8 mm																							
0.75 mm <sup>2</sup> AWG 18	1.3 mm	8 mm																							
1 mm <sup>2</sup> AWG 18	1.45 mm	8 mm																							
1.5 mm <sup>2</sup> AWG 16	1.75 mm	8 mm																							
2.5 mm <sup>2</sup> AWG 14	2.25 mm	6 mm																							
Han D®, Crimp contact, Contact surface: Gold plated 	0,14 ... 0,37 0,5 0,75 1 1,5 2,5	09 15 000 6124 09 15 000 6123 09 15 000 6125 09 15 000 6122 09 15 000 6121 09 15 000 6126	09 15 000 6224 09 15 000 6223 09 15 000 6225 09 15 000 6222 09 15 000 6221 09 15 000 6226	 <table border="1"> <thead> <tr> <th>Wire gauge</th> <th>∅</th> <th>Stripping length</th> </tr> </thead> <tbody> <tr> <td>0.14-0.37 mm<sup>2</sup> AWG 26-22</td> <td>0.9 mm</td> <td>8 mm</td> </tr> <tr> <td>0.5 mm<sup>2</sup> AWG 20</td> <td>1.1 mm</td> <td>8 mm</td> </tr> <tr> <td>0.75 mm<sup>2</sup> AWG 18</td> <td>1.3 mm</td> <td>8 mm</td> </tr> <tr> <td>1 mm<sup>2</sup> AWG 18</td> <td>1.45 mm</td> <td>8 mm</td> </tr> <tr> <td>1.5 mm<sup>2</sup> AWG 16</td> <td>1.75 mm</td> <td>8 mm</td> </tr> <tr> <td>2.5 mm<sup>2</sup> AWG 14</td> <td>2.25 mm</td> <td>6 mm</td> </tr> </tbody> </table>	Wire gauge	∅	Stripping length	0.14-0.37 mm <sup>2</sup> AWG 26-22	0.9 mm	8 mm	0.5 mm <sup>2</sup> AWG 20	1.1 mm	8 mm	0.75 mm <sup>2</sup> AWG 18	1.3 mm	8 mm	1 mm <sup>2</sup> AWG 18	1.45 mm	8 mm	1.5 mm <sup>2</sup> AWG 16	1.75 mm	8 mm	2.5 mm <sup>2</sup> AWG 14	2.25 mm	6 mm
Wire gauge	∅	Stripping length																							
0.14-0.37 mm <sup>2</sup> AWG 26-22	0.9 mm	8 mm																							
0.5 mm <sup>2</sup> AWG 20	1.1 mm	8 mm																							
0.75 mm <sup>2</sup> AWG 18	1.3 mm	8 mm																							
1 mm <sup>2</sup> AWG 18	1.45 mm	8 mm																							
1.5 mm <sup>2</sup> AWG 16	1.75 mm	8 mm																							
2.5 mm <sup>2</sup> AWG 14	2.25 mm	6 mm																							
FO contact, for 1 mm plastic fibre 		20 10 001 3211	20 10 001 3221	 20 10 001 3211 + 20 10 001 3221																					

## Features

- Suitable for D-Sub crimp contacts
- High packing density

## Technical characteristics

Number of contacts	25
Electrical data acc. to IEC 61984	4 A 50 V 0,8 kV 3
Rated current	4 A
Rated voltage	50 V
Rated impulse voltage	0.8 kV
Pollution degree	3
Rated voltage acc. to UL	30 V
Insulation resistance	$\geq 10^{10} \Omega$
Limiting temperature	-40 ... +125 °C
Flammability acc. to UL 94	V-0
Mating cycles	$\geq 500$
Material (insert)	Polycarbonate
Colour (insert)	RAL 7032 (pebble grey)
Material (contacts)	Copper alloy

## Derating

### Current carrying capacity

The current carrying capacity of the connectors is limited by the thermal load capability of the contact element material including the connections and the insulating parts. The derating curve is therefore valid for currents which flow constantly (non-intermittent) through each contact element of the connector evenly, without exceeding the allowed maximum temperature.

Measuring and testing techniques acc. to IEC 60512-5-2

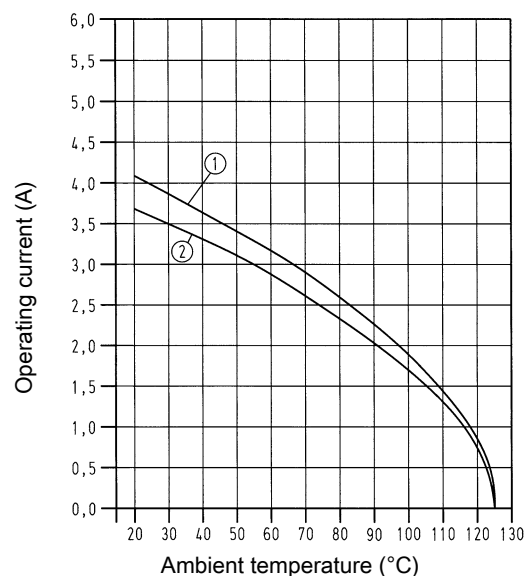

- ① 24 B hoods/housings with 6 modules; turned contacts Conductor cross-section 0.5 mm<sup>2</sup>
- ② 24 B hoods/housings with 6 modules; stamped contacts Conductor cross-section 0.5 mm<sup>2</sup>

## Specifications and approvals

EN 60664-1  
IEC 61984  
UL 1977 ECBT2.E235076



## Details



Guide pins and bushes are recommended (see chapter 80).

Number of contacts

# 25

4 A 50 V 0,8 kV 3

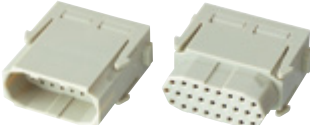
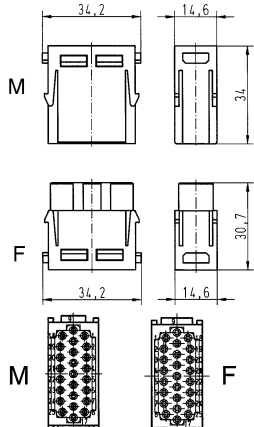
Modu-  
lar

Identification	Conductor cross-section (mm <sup>2</sup> )	Part number		Drawing (dimensions in mm)												
		Male	Female													
Han-Modular®, Han® High Density module, Crimp termination  <p>Please order crimp contacts separately.</p>	0,09 ... 0,52	09 14 025 3001	09 14 025 3101	 <p>Contact arrangement (view from termination side)</p>												
D-Sub , Crimp contact, Turned , Pack contents: Single contact 	0,09 ... 0,25 0,13 ... 0,33 0,25 ... 0,52	09 67 000 7576 09 67 000 5576 09 67 000 8576	09 67 000 7476 09 67 000 5476 09 67 000 8476	<table border="1"> <thead> <tr> <th>Wire gauge</th> <th>max. insulation diameter</th> <th>Stripping length</th> </tr> </thead> <tbody> <tr> <td>0.09-0.25 mm<sup>2</sup></td> <td>1.7</td> <td>4 mm</td> </tr> <tr> <td>0.13-0.33 mm<sup>2</sup></td> <td>1.7</td> <td>4 mm</td> </tr> <tr> <td>0.25-0.52 mm<sup>2</sup></td> <td>1.7</td> <td>4 mm</td> </tr> </tbody> </table>	Wire gauge	max. insulation diameter	Stripping length	0.09-0.25 mm <sup>2</sup>	1.7	4 mm	0.13-0.33 mm <sup>2</sup>	1.7	4 mm	0.25-0.52 mm <sup>2</sup>	1.7	4 mm
Wire gauge	max. insulation diameter	Stripping length														
0.09-0.25 mm <sup>2</sup>	1.7	4 mm														
0.13-0.33 mm <sup>2</sup>	1.7	4 mm														
0.25-0.52 mm <sup>2</sup>	1.7	4 mm														



## Features

- 9-pin D-Sub connector of the Han-Modular® system
- Suitable for the transmission of sensitive signals
- Compatible to crimp, solder or IDC termination

## Technical characteristics

Number of contacts	9
Electrical data acc. to IEC 61984	5 A 50 V 0,8 kV 3
Rated current	5 A
Rated voltage	50 V
Rated impulse voltage	0.8 kV
Pollution degree	3
Rated voltage acc. to UL	30 V
Insulation resistance	$\geq 10^{10} \Omega$
Limiting temperature	-40 ... +125 °C
Flammability acc. to UL 94	V-0
Mating cycles	$\geq 500$
Material (insert)	Polycarbonate, Zinc die-cast
Colour (insert)	RAL 7032 (pebble grey)
Material (contacts)	Copper alloy

## Specifications and approvals

EN 60664-1  
IEC 61984  
UL 1977 ECBT2.E235076



## Details





Guide pins and bushes are recommended (see chapter 80).

Number of contacts

# 9

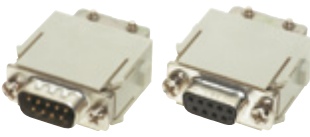
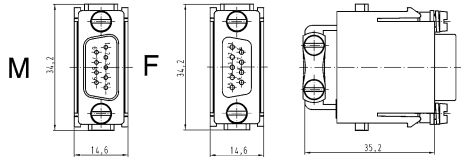
5 A 50 V 0,8 kV 3

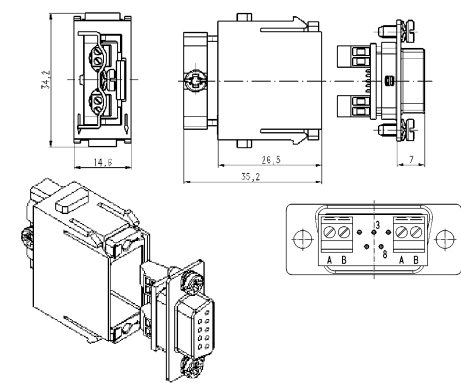
Modular

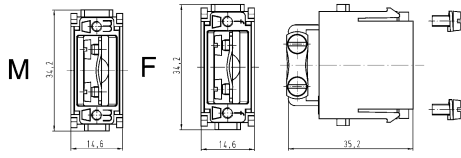
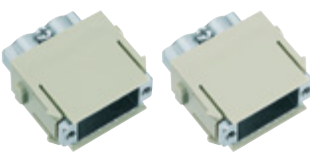
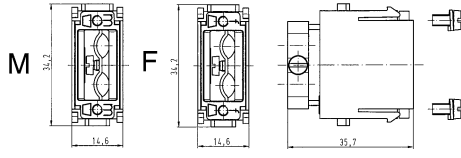
Identification	Conductor cross-section (mm <sup>2</sup> )	Part number		Drawing (dimensions in mm)
		Male	Female	
Han-Modular®, Han® D-Sub module, Crimp termination  <p>Please order crimp contacts separately.</p>	0,08 ... 0,52	09 14 009 3001	09 14 009 3101	
Han-Modular®, Han® D-Sub module, Screw termination  <p>for RS 485-based bus systems with T-functionality</p>	0,08 ... 0,52		09 14 009 3151	 <p>Contact arrangement (view from termination side)                      Signal A: Contact no. 8                      Signal B: Contact no. 3</p>
Han-Modular®, Adapter module, for 9-pin D-Sub  <p>for one cable</p>		09 14 000 9930	09 14 000 9931	
Han-Modular®, Adapter module, for 9-pin D-Sub  <p>for two cables</p>		09 14 000 9932	09 14 000 9933	

Identification	Conductor cross-section (mm <sup>2</sup> )	Part number		Drawing (dimensions in mm)												
		Male	Female													
D-Sub , Crimp contact, Turned , Pack contents: Single contact 	0,09 ... 0,25	09 67 000 7576	09 67 000 7476	<table border="1"> <thead> <tr> <th>Wire gauge</th> <th>max. insulation diameter</th> <th>Stripping length</th> </tr> </thead> <tbody> <tr> <td>0.09-0.25 mm<sup>2</sup></td> <td>1.7</td> <td>4 mm</td> </tr> <tr> <td>0.13-0.33 mm<sup>2</sup></td> <td>1.7</td> <td>4 mm</td> </tr> <tr> <td>0.25-0.52 mm<sup>2</sup></td> <td>1.7</td> <td>4 mm</td> </tr> </tbody> </table>	Wire gauge	max. insulation diameter	Stripping length	0.09-0.25 mm <sup>2</sup>	1.7	4 mm	0.13-0.33 mm <sup>2</sup>	1.7	4 mm	0.25-0.52 mm <sup>2</sup>	1.7	4 mm
	Wire gauge	max. insulation diameter	Stripping length													
	0.09-0.25 mm <sup>2</sup>	1.7	4 mm													
	0.13-0.33 mm <sup>2</sup>	1.7	4 mm													
0.25-0.52 mm <sup>2</sup>	1.7	4 mm														
0,13 ... 0,33	09 67 000 5576	09 67 000 5476														
0,25 ... 0,52	09 67 000 8576	09 67 000 8476														

Modu-  
lar

## Features

- According to USB 2.0 / USB 3.0 specification
- Simple and cost effective termination by plug in patch cable
- Cable tie strain relief

## Technical characteristics

Number of contacts	4, 8
Electrical data acc. to IEC 61984	1 A 50 V 0,8 kV 3
Rated current	1 A
Rated voltage	50 V
Rated impulse voltage	0.8 kV
Pollution degree	3
Rated voltage acc. to UL	30 V
Insulation resistance	$\geq 10^{10} \Omega$
Limiting temperature	-40 ... +85 °C
Flammability acc. to UL 94	V-0
Mating cycles	$\geq 500$
Material (insert)	Polycarbonate
Colour (insert)	RAL 7032 (pebble grey)

## Specifications and approvals





EN 60664-1  
IEC 60352-4  
UL 1977 ECBT2.E235076

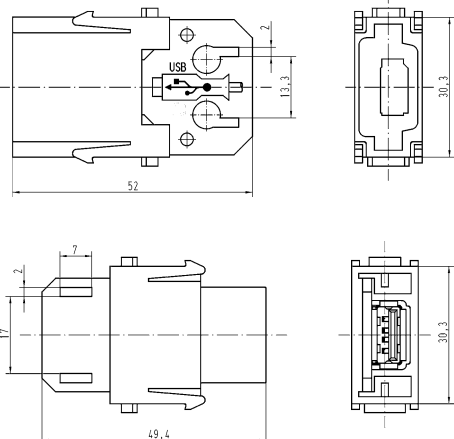

Number of contacts

# 4

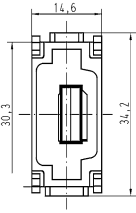
1 A 50 V 0,8 kV 3

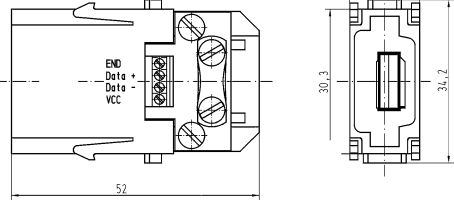
Identification	Part number		Drawing (dimensions in mm)
	Male	Female	
Han-Modular®, Han® USB module, for patch cable    USB 2.0	09 14 001 4601	09 14 001 4701	
Han-Modular®, Han® USB module, for patch cable    USB 3.0		09 14 001 4703	
Han-Modular®, Han® USB module, for screw termination    USB 2.0	09 14 001 4651		

Modular

Number of contacts

# 6

1 A 50 V 0,8 kV 3

## Features

- Compatibel to IEEE 1394
- Simple and cost effective termination by plug in patch cable
- Cable tie strain relief

## Technical characteristics

Number of contacts	6
Electrical data acc. to IEC 61984	1 A 50 V 0,8 kV 3
Rated current	1 A
Rated voltage	50 V
Rated impulse voltage	0.8 kV
Pollution degree	3
Insulation resistance	$\geq 10^{10} \Omega$
Limiting temperature	-40 ... +85 °C
Flammability acc. to UL 94	V-0
Mating cycles	$\geq 500$
Material (insert)	Polycarbonate
Colour (insert)	RAL 7032 (pebble grey)

## Specifications and approvals

EN 60664-1  
IEC 61984  
UL 1977 ECBT2.E235076

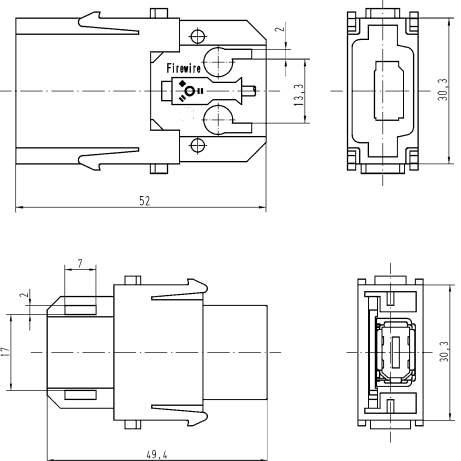

Modu-  
lar

Identification	Part number		Drawing (dimensions in mm)
	Male	Female	
Han-Modular®, Han® FireWire module, for patch cable  	09 14 001 4611	09 14 001 4711	

Number of contacts

# 8

## Features

- Single module with standard shielded RJ45 plug and jack
- Cat. 6 for all data pairs (8-pin)
- Patch cables are assembled/removed without tools

## Technical characteristics

Number of contacts	8, 4
Electrical data acc. to IEC 61984	1 A 50 V 0,8 kV 3
Rated current	1 A
Rated voltage	50 V
Rated impulse voltage	0.8 kV
Pollution degree	3
Rated voltage acc. to UL	30 V
Insulation resistance	$\geq 10^{10} \Omega$
Limiting temperature	-40 ... +70 °C
Flammability acc. to UL 94	V-0
Mating cycles	$\geq 500$
Transmission characteristics	Category, 6 <sub>A</sub> , 5
Material (insert)	Zinc die-cast, nickel-plated, Polycarbonate
Colour (insert)	RAL 7032 (pebble grey)

## Specifications and approvals

EN 60664-1  
IEC 61984  
UL 1977 ECBT2.E235076



Modu-  
lar

### Identification

### Part number

### Drawing (dimensions in mm)

Han-Modular®,  
Han® RJ45 module,  
Single module



Please order insert separately.

Han-Modular®,  
Han® RJ45 module,  
Gender changer,  
for patch cable,  
8-pins,  
Cat. 6<sub>A</sub>



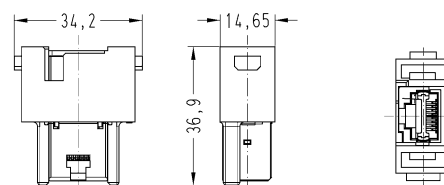

09 14 001 4722

09 14 001 4721



Modu-  
lar

Identification		Part number	Drawing (dimensions in mm)
<p>Data connectors, Han® RJ45 cable jack, preLink® termination, 8-pins, Cat. 6<sub>A</sub></p> 	<p>AWG 23 ... AWG 22</p>	<p>09 14 008 4720</p>	
<p>Data connectors, Han® RJ45 cable jack, IDC termination, 4-pin, Cat. 5</p> 	<p>AWG 24 ... AWG 22</p>	<p>09 14 545 1120</p>	
<p>Data connectors, Han® RJ45 cable jack, IDC termination, 8-pins, Cat. 6<sub>A</sub></p> 	<p>AWG 24 ... AWG 22 AWG 28 ... AWG 24</p>	<p>09 14 545 1562 09 14 545 1561</p>	



Number of contacts

# 8

1 A 50 V 0,8 kV 3

## Features

- Single module with standard shielded RJ45 plug and jack
- The RJ45 inserts are protected by a reliable plastic insulator

## Technical characteristics

Number of contacts	8
Electrical data acc. to IEC 61984	1 A 50 V 0,8 kV 3
Rated current	1 A
Rated voltage	50 V
Rated impulse voltage	0.8 kV
Pollution degree	3
Rated voltage acc. to UL	30 V
Insulation resistance	$\geq 10^{10} \Omega$
Limiting temperature	-40 ... +125 °C, -40 ... +70 °C
Flammability acc. to UL 94	V-0
Mating cycles	$\geq 500$
Transmission characteristics	Category, 5
Material (insert)	Polycarbonate
Colour (insert)	RAL 7032 (pebble grey)

## Specifications and approvals

EN 60664-1  
IEC 61984  
UL 1977 ECBT2.E235076



Modular

### Identification

Han-Modular®,  
Han® RJ45 module



for data connectors

RJ45 ,  
Data connectors,  
for Han® RJ45 module,  
Cat. 5



### Part number

09 14 001 4622

09 12 000 9958

### Drawing (dimensions in mm)

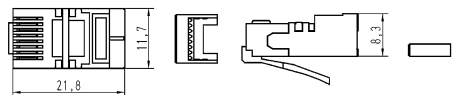
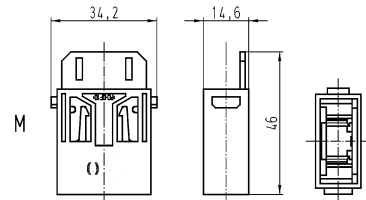

Modular

## Features

- Single module with standard shielded RJ45 plug and jack
- The RJ45 inserts are protected by a reliable plastic insulator
- 360° shielded contact
- Field assembly without tools possible by means of *HARAX*® rapid termination in IDC technology
- Gigalink: Field assembly by means of piercing contacts (Assembly tool 09 45 800 0520)
- Suitable for termination of massive and flexible wires
- Gigalink: Suitable for termination of flexible wires





## Technical characteristics

Number of contacts	4, 8
Limiting temperature	-40 ... +125 °C, -40 ... +70 °C
Flammability acc. to UL 94	V-0
Mating cycles	≥500
Transmission characteristics	Category, 5, 6 <sub>A</sub> , 6
Data rate	10 Mbit/s, 100 Mbit/s, 1000 Mbit/s, 10000 Mbit/s
Material (insert)	Polycarbonate, Polyamide
Colour (insert)	RAL 7032 (pebble grey)

## Specifications and approvals

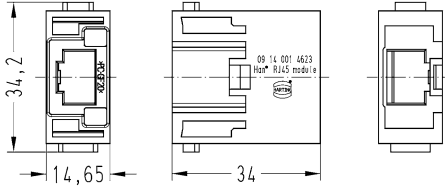
EN 60664-1  
IEC 61984  
UL 1977 ECBT2.E235076  
IEC 60603-7

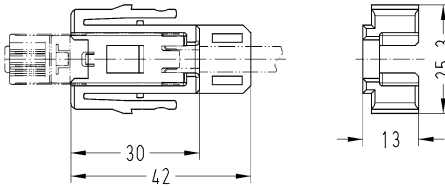

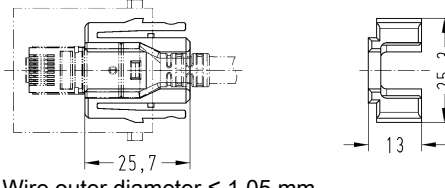
Identification	Part number	Drawing (dimensions in mm)
<p>Han-Modular®, Han® RJ45 module, Single module, for adapter</p>  <p>Please order adapter separately.</p>	09 14 001 4623	
<p>Data connectors, RJ Industrial RJ45 connector set, Cat. 5, 100 Mbit/s, 4-pin</p> 	<p>AWG 24 ... AWG 22 AWG 26</p> <p>09 45 400 1100 09 45 400 1109</p>	 <p>Wire outer diameter ≤ 1.6 mm</p>
<p>Data connectors, RJ Industrial RJ45 Gigalink connector set, Cat. 6<sub>A</sub>, 10000 Mbit/s, 8-pins</p> 	<p>AWG 28 ... AWG 24</p> <p>09 45 400 1520</p>	 <p>Wire outer diameter ≤ 1.05 mm</p>

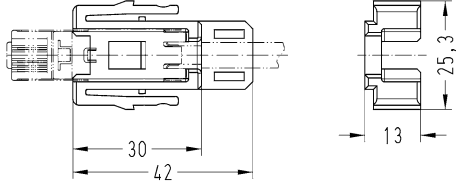
Identification	Part number	Drawing (dimensions in mm)
<p>Data connectors, RJ Industrial RJ45 connector set, Cat. 6, 10000 Mbit/s, 8-pins</p> 	<p>AWG 27 ... AWG 22</p>	<p>09 45 400 1560</p>  <p>Wire outer diameter <math>\leq 1.5</math> mm</p>

Modu-  
lar

Modu-  
lar

## Features

- Single module with standard shielded RJ45 plug and jack
- The RJ45 inserts are protected by a reliable plastic insulator
- Patch cables are assembled/removed without tools

## Technical characteristics

Limiting temperature	-40 ... +125 °C
Flammability acc. to UL 94	V-0
Mating cycles	≥500
Material (insert)	Polycarbonate
Colour (insert)	RAL 7032 (pebble grey)

## Specifications and approvals

EN 60664-1  
IEC 61984  
UL 1977 ECBT2.E235076



### Identification

Han-Modular®,  
Han® RJ45 module,  
Single module,  
for adapter



Please order adapter separately.

Han-Modular®,  
Han® RJ45 module,  
Adapter,  
for patch cable



### Part number

09 14 001 4623

09 14 000 9966

### Drawing (dimensions in mm)

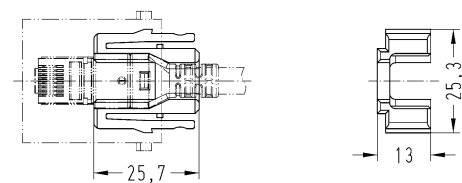
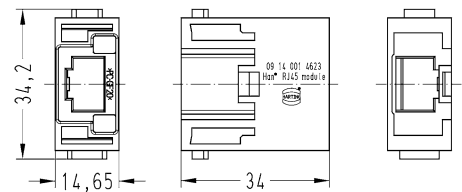



## Features

- Locking lever protection for RJ45 connector latch
- Very short plug design in combination with robust bend protection
- Fully EMC screened (aluminium-clad foil and braid)

## Technical characteristics

Core structure	4x 2 Twisted Pair
Connector 1	HARTING RJ Industrial®
Connector 2	HARTING RJ Industrial®
Limiting temperature	-30 ... +75 °C, -5 ... +50 °C moved
Degree of protection acc. to IEC 60529	IP20
Transmission characteristics	Category, 5e
Data rate	10 Mbit/s, 100 Mbit/s, 1000 Mbit/s
Material (cable)	PUR (polyurethane)
Colour (cable)	Yellow

## Specifications and approvals

IEC 11801  
IEC 24702  
IEC 61935-2  
IEC 60754-1

Modular

Identification	Cable length	Part number	Drawing (dimensions in mm)
RJ45 , Copper cable (round), Halogen-free, oil resistant, Pre-assembled on both sides	0.2 m	09 47 474 7001	
	0.3 m	09 47 474 7002	
	0.4 m	09 47 474 7003	
	0.5 m	09 47 474 7004	
	0.6 m	09 47 474 7005	
	0.7 m	09 47 474 7006	
	0.8 m	09 47 474 7007	
	0.9 m	09 47 474 7008	
	1 m	09 47 474 7009	
	1.5 m	09 47 474 7010	
	2 m	09 47 474 7011	
	2.5 m	09 47 474 7012	
	3 m	09 47 474 7013	
	3.5 m	09 47 474 7024	
	4 m	09 47 474 7014	
	5 m	09 47 474 7015	
	6 m	09 47 474 7016	
	7 m	09 47 474 7017	
	7.5 m	09 47 474 7018	
	8 m	09 47 474 7019	
	9 m	09 47 474 7020	
	10 m	09 47 474 7021	
	12 m	09 47 474 7035	
	15 m	09 47 474 7022	
	20 m	09 47 474 7023	
	25 m	09 47 474 7025	
	30 m	09 47 474 7027	
	35 m	09 47 474 7026	
	40 m	09 47 474 7028	
50 m	09 47 474 7029		



## Features

- Locking lever protection for RJ45 connector latch
- Very short plug design in combination with robust bend protection
- Fully EMC screened (aluminium-clad foil and braid)

## Technical characteristics

Core structure	4x 2 Twisted Pair
Connector 1	HARTING RJ Industrial®
Connector 2	HARTING RJ Industrial®
Limiting temperature	-30 ... +75 °C, +5 ... +50 °C moved
Degree of protection acc. to IEC 60529	IP20
Transmission characteristics	Category, 6
Data rate	10 Mbit/s, 100 Mbit/s, 1000 Mbit/s, 10 Gbit/s
Material (cable)	PUR (polyurethane)
Colour (cable)	Yellow

## Specifications and approvals

IEC 11801  
IEC 60754-1  
IEC 61156-6  
IEC 24702

Identification	Cable length	Part number	Drawing (dimensions in mm)
RJ45 , Copper cable (round), Wiring 1:1, Halogen-free, oil resistant, Pre-assembled on both sides	0.2 m	09 47 474 7101	
	0.3 m	09 47 474 7102	
	0.4 m	09 47 474 7103	
	0.5 m	09 47 474 7104	
	0.6 m	09 47 474 7105	
	0.7 m	09 47 474 7106	
	0.8 m	09 47 474 7107	
	0.9 m	09 47 474 7108	
	1 m	09 47 474 7109	
	1.5 m	09 47 474 7110	
	2 m	09 47 474 7111	
	2.5 m	09 47 474 7112	
	3 m	09 47 474 7113	
	4 m	09 47 474 7114	
	5 m	09 47 474 7115	
	6 m	09 47 474 7116	
	7 m	09 47 474 7117	
	7.5 m	09 47 474 7118	
	8 m	09 47 474 7119	
	9 m	09 47 474 7120	
10 m	09 47 474 7121		
15 m	09 47 474 7122		
16 m	09 47 474 7124		
20 m	09 47 474 7123		
25 m	09 47 474 7126		
30 m	09 47 474 7125		
100 m	09 47 474 7199		

Modular

## Features

- Shielding bus separate from housing potential
- Suitable for the transmission of sensitive signals (e.g. bus signals)
- Usable for Gigabit Ethernet cat. 6<sub>A</sub>

## Technical characteristics

Number of contacts	8
Additional contacts	+ shielding
Electrical data acc. to IEC 61984	5 A 50 V 0,8 kV 3
Rated current	5 A
Rated voltage	50 V
Rated impulse voltage	0.8 kV
Pollution degree	3
Insulation resistance	≥10 <sup>10</sup> Ω
Limiting temperature	-40 ... +85 °C
Flammability acc. to UL 94	V-0
Mating cycles	≥500
Transmission characteristics	Category, 6 <sub>A</sub>
Material (insert)	Zinc die-cast, nickel-plated, Polycarbonate
Colour (insert)	RAL 7032 (pebble grey)
Material (contacts)	Copper alloy

## Specifications and approvals

EN 60664-1  
IEC 61984  
UL 1977 ECBT2.E235076







Number of contacts

# 8

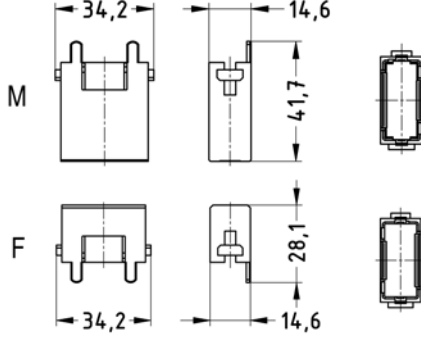
5 A 50 V 0,8 kV 3  
+ shielding

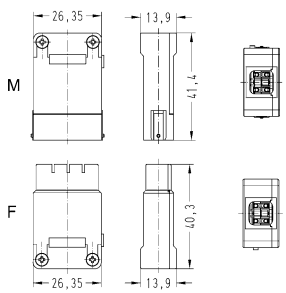
Modular

Identification	Conductor cross-section (mm <sup>2</sup> )	Part number		Drawing (dimensions in mm)												
		Male	Female													
Han-Modular®, Adapter module 		09 14 001 3011	09 14 001 3111													
Han® Gigabit insert, Crimp termination  Please order crimp contacts separately. Please order adapter module separately.	0,09 ... 0,52	09 14 008 3011	09 14 008 3111	 Cable outer diameter 5 ... 12												
D-Sub , Crimp contact, Turned , Pack contents: Single contact 	0,09 ... 0,25 0,13 ... 0,33 0,25 ... 0,52	09 67 000 7576 09 67 000 5576 09 67 000 8576	09 67 000 7476 09 67 000 5476 09 67 000 8476	<table border="1"> <thead> <tr> <th>Wire gauge</th> <th>max. insulation diameter</th> <th>Stripping length</th> </tr> </thead> <tbody> <tr> <td>0.09-0.25 mm<sup>2</sup></td> <td>1.7</td> <td>4 mm</td> </tr> <tr> <td>0.13-0.33 mm<sup>2</sup></td> <td>1.7</td> <td>4 mm</td> </tr> <tr> <td>0.25-0.52 mm<sup>2</sup></td> <td>1.7</td> <td>4 mm</td> </tr> </tbody> </table>	Wire gauge	max. insulation diameter	Stripping length	0.09-0.25 mm <sup>2</sup>	1.7	4 mm	0.13-0.33 mm <sup>2</sup>	1.7	4 mm	0.25-0.52 mm <sup>2</sup>	1.7	4 mm
Wire gauge	max. insulation diameter	Stripping length														
0.09-0.25 mm <sup>2</sup>	1.7	4 mm														
0.13-0.33 mm <sup>2</sup>	1.7	4 mm														
0.25-0.52 mm <sup>2</sup>	1.7	4 mm														



## Features

- Shielding bus separate from housing potential
- Suitable for the transmission of sensitive signals (e.g. bus signals)

## Technical characteristics

Number of contacts	20
Electrical data acc. to IEC 61984	4 A 32 V 0,8 kV 3
Rated current	4 A
Rated voltage	32 V
Rated impulse voltage	0.8 kV
Pollution degree	3
Insulation resistance	$\geq 10^{10} \Omega$
Contact resistance	$\leq 4 \text{ m}\Omega$
Limiting temperature	-40 ... +85 °C
Flammability acc. to UL 94	V-0
Mating cycles	$\geq 500$
Material (insert)	Zinc die-cast, nickel-plated, LCP, Polycarbonate
Colour (insert)	RAL 7032 (pebble grey)
Material (contacts)	Copper alloy

## Specifications and approvals

EN 60664-1  
IEC 61984  
UL 1977 ECBT2.E235076







Number of contacts

# 20

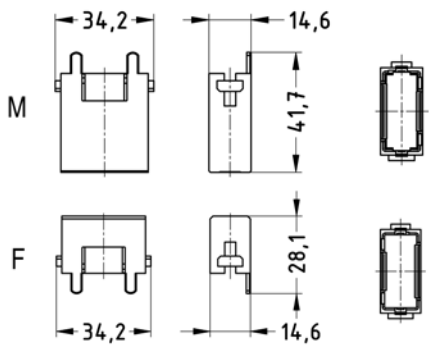
4 A 32 V 0,8 kV 3

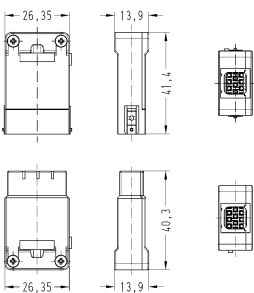
Modular

Identification	Conductor cross-section (mm <sup>2</sup> )	Part number		Drawing (dimensions in mm)												
		Male	Female													
Han-Modular®, Adapter module 		09 14 001 3011	09 14 001 3111													
Han® Shielded Module insert, Crimp termination  Please order crimp contacts separately.	0,09 ... 0,52	09 14 020 3013	09 14 020 3113													
D-Sub , Crimp contact, Turned , Pack contents: Single contact 	0,09 ... 0,25 0,13 ... 0,33 0,25 ... 0,52	09 67 000 7576 09 67 000 5576 09 67 000 8576	09 67 000 7476 09 67 000 5476 09 67 000 8476	<table border="1"> <thead> <tr> <th>Wire gauge</th> <th>max. insulation diameter</th> <th>Stripping length</th> </tr> </thead> <tbody> <tr> <td>0.09-0.25 mm<sup>2</sup></td> <td>1.7</td> <td>4 mm</td> </tr> <tr> <td>0.13-0.33 mm<sup>2</sup></td> <td>1.7</td> <td>4 mm</td> </tr> <tr> <td>0.25-0.52 mm<sup>2</sup></td> <td>1.7</td> <td>4 mm</td> </tr> </tbody> </table>	Wire gauge	max. insulation diameter	Stripping length	0.09-0.25 mm <sup>2</sup>	1.7	4 mm	0.13-0.33 mm <sup>2</sup>	1.7	4 mm	0.25-0.52 mm <sup>2</sup>	1.7	4 mm
Wire gauge	max. insulation diameter	Stripping length														
0.09-0.25 mm <sup>2</sup>	1.7	4 mm														
0.13-0.33 mm <sup>2</sup>	1.7	4 mm														
0.25-0.52 mm <sup>2</sup>	1.7	4 mm														

## Features

- Shielding bus separate from housing potential
- Usable for Megabit Ethernet cat. 5e
- Suitable for Han B, Han M, Han EMC and Han HPR hoods/housings, high construction

## Technical characteristics

Number of contacts	8
Additional contacts	+ shielding
Electrical data acc. to IEC 61984	10 A 50 V 0,8 kV 3
Rated current	10 A
Rated voltage	50 V
Rated impulse voltage	0.8 kV
Pollution degree	3
Insulation resistance	≥10 <sup>10</sup> Ω
Contact resistance	≤3 mΩ
Limiting temperature	-40 ... +85 °C
Flammability acc. to UL 94	V-0
Mating cycles	≥500
Material (insert)	Zinc die-cast, nickel-plated, Polycarbonate
Colour (insert)	RAL 7032 (pebble grey)
Material (contacts)	Copper alloy

## Specifications and approvals

EN 60664-1  
IEC 61984  
UL 1977 ECBT2.E235076



## Details

**Crimping tools** see chapter 90

### Remarks on the crimp technique



The wire gauges mentioned in the catalogue refer to geometric wire gauges of cables.

Number of contacts

# 8

10 A 50 V 0,8 kV 3

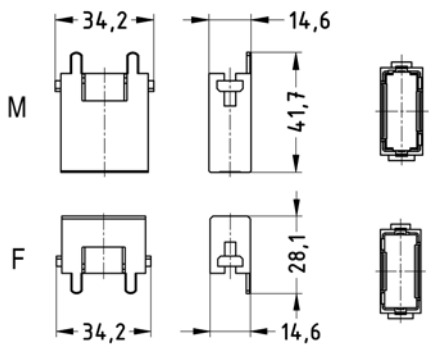
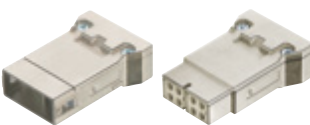
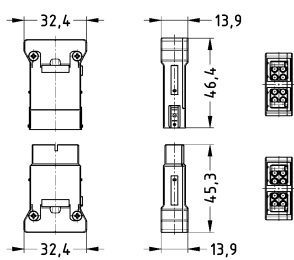
Modular

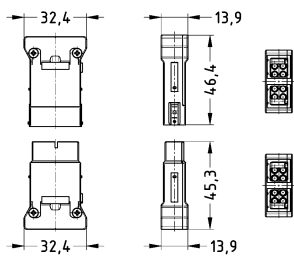

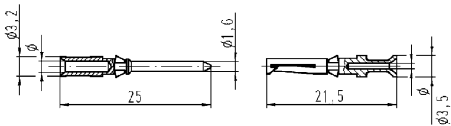

Identification	Conductor cross-section (mm <sup>2</sup> )	Part number		Drawing (dimensions in mm)
		Male	Female	
Han-Modular®, Adapter module 		09 14 001 3011	09 14 001 3111	
Han® Megabit insert, 2 x 4 contacts, 2 cable entries, Crimp termination  <p>Please order crimp contacts separately. Please order adapter module separately.</p>	0,14 ... 2,5	09 14 008 3016	09 14 008 3116	
Han® Megabit insert, 2 x 4 contacts, One entry, Crimp termination  <p>2 x 4 contacts Please order crimp contacts separately. Please order adapter module separately.</p>	0,14 ... 2,5	09 14 008 3021	09 14 008 3121	

Identification	Conductor cross-section (mm <sup>2</sup> )	Part number		Drawing (dimensions in mm)																					
		Male	Female																						
Han D®, Crimp contact, Contact surface: Gold plated 	0,14 ... 0,37	09 15 000 6124	09 15 000 6224	 <table border="1" data-bbox="992 499 1449 658"> <thead> <tr> <th>Wire gauge</th> <th><math>\phi</math></th> <th>Stripping length</th> </tr> </thead> <tbody> <tr> <td>0.14-0.37 mm<sup>2</sup> AWG 26-22</td> <td>0.9 mm</td> <td>8 mm</td> </tr> <tr> <td>0.5 mm<sup>2</sup> AWG 20</td> <td>1.1 mm</td> <td>8 mm</td> </tr> <tr> <td>0.75 mm<sup>2</sup> AWG 18</td> <td>1.3 mm</td> <td>8 mm</td> </tr> <tr> <td>1 mm<sup>2</sup> AWG 18</td> <td>1.45 mm</td> <td>8 mm</td> </tr> <tr> <td>1.5 mm<sup>2</sup> AWG 16</td> <td>1.75 mm</td> <td>8 mm</td> </tr> <tr> <td>2.5 mm<sup>2</sup> AWG 14</td> <td>2.25 mm</td> <td>6 mm</td> </tr> </tbody> </table>	Wire gauge	$\phi$	Stripping length	0.14-0.37 mm <sup>2</sup> AWG 26-22	0.9 mm	8 mm	0.5 mm <sup>2</sup> AWG 20	1.1 mm	8 mm	0.75 mm <sup>2</sup> AWG 18	1.3 mm	8 mm	1 mm <sup>2</sup> AWG 18	1.45 mm	8 mm	1.5 mm <sup>2</sup> AWG 16	1.75 mm	8 mm	2.5 mm <sup>2</sup> AWG 14	2.25 mm	6 mm
	Wire gauge	$\phi$	Stripping length																						
	0.14-0.37 mm <sup>2</sup> AWG 26-22	0.9 mm	8 mm																						
	0.5 mm <sup>2</sup> AWG 20	1.1 mm	8 mm																						
	0.75 mm <sup>2</sup> AWG 18	1.3 mm	8 mm																						
	1 mm <sup>2</sup> AWG 18	1.45 mm	8 mm																						
1.5 mm <sup>2</sup> AWG 16	1.75 mm	8 mm																							
2.5 mm <sup>2</sup> AWG 14	2.25 mm	6 mm																							
0,5	09 15 000 6123	09 15 000 6223																							
0,75	09 15 000 6125	09 15 000 6225																							
1	09 15 000 6122	09 15 000 6222																							
1,5	09 15 000 6121	09 15 000 6221																							
2,5	09 15 000 6126	09 15 000 6226																							

Number of contacts

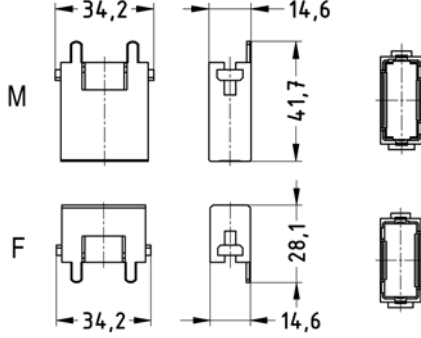
# 8

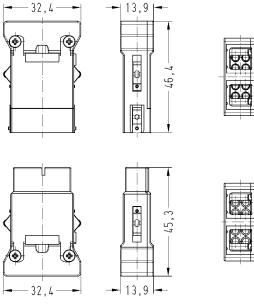
10 A 50 V 0,8 kV 3  
+ shielding

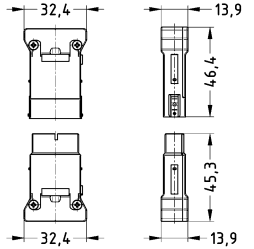
Identification	Conductor cross-section (mm <sup>2</sup> )	Part number		Drawing (dimensions in mm)
		Male	Female	
<p>Han-Modular®, Adapter module</p> 		09 14 001 3011	09 14 001 3111	
<p>Han® Megabit insert, 2 x 4 contacts, 2 cable entries, Crimp termination</p>  <p>With additional shield connection to the hinged frame Please order crimp contacts separately. Please order adapter module separately.</p>	0,14 ... 2,5	09 14 008 3017	09 14 008 3117	
<p>Han® Megabit insert, 2 x 4 contacts, One entry, Crimp termination</p>  <p>2 x 4 contacts With additional shield connection to the hinged frame Please order crimp contacts separately. Please order adapter module separately.</p>	0,14 ... 2,5	09 14 008 3022	09 14 008 3122	

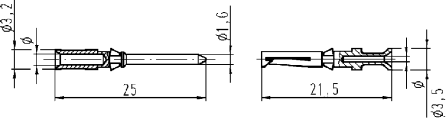
Identification	Conductor cross-section (mm <sup>2</sup> )	Part number		Drawing (dimensions in mm)																					
		Male	Female																						
Han D®, Crimp contact, Contact surface: Gold plated 	0,14 ... 0,37	09 15 000 6124	09 15 000 6224	 <table border="1" data-bbox="994 499 1449 658"> <thead> <tr> <th>Wire gauge</th> <th><math>\phi</math></th> <th>Stripping length</th> </tr> </thead> <tbody> <tr> <td>0.14-0.37 mm<sup>2</sup> AWG 26-22</td> <td>0.9 mm</td> <td>8 mm</td> </tr> <tr> <td>0.5 mm<sup>2</sup> AWG 20</td> <td>1.1 mm</td> <td>8 mm</td> </tr> <tr> <td>0.75 mm<sup>2</sup> AWG 18</td> <td>1.3 mm</td> <td>8 mm</td> </tr> <tr> <td>1 mm<sup>2</sup> AWG 18</td> <td>1.45 mm</td> <td>8 mm</td> </tr> <tr> <td>1.5 mm<sup>2</sup> AWG 16</td> <td>1.75 mm</td> <td>8 mm</td> </tr> <tr> <td>2.5 mm<sup>2</sup> AWG 14</td> <td>2.25 mm</td> <td>6 mm</td> </tr> </tbody> </table>	Wire gauge	$\phi$	Stripping length	0.14-0.37 mm <sup>2</sup> AWG 26-22	0.9 mm	8 mm	0.5 mm <sup>2</sup> AWG 20	1.1 mm	8 mm	0.75 mm <sup>2</sup> AWG 18	1.3 mm	8 mm	1 mm <sup>2</sup> AWG 18	1.45 mm	8 mm	1.5 mm <sup>2</sup> AWG 16	1.75 mm	8 mm	2.5 mm <sup>2</sup> AWG 14	2.25 mm	6 mm
	Wire gauge	$\phi$	Stripping length																						
	0.14-0.37 mm <sup>2</sup> AWG 26-22	0.9 mm	8 mm																						
	0.5 mm <sup>2</sup> AWG 20	1.1 mm	8 mm																						
	0.75 mm <sup>2</sup> AWG 18	1.3 mm	8 mm																						
	1 mm <sup>2</sup> AWG 18	1.45 mm	8 mm																						
1.5 mm <sup>2</sup> AWG 16	1.75 mm	8 mm																							
2.5 mm <sup>2</sup> AWG 14	2.25 mm	6 mm																							
0,5	09 15 000 6123	09 15 000 6223																							
0,75	09 15 000 6125	09 15 000 6225																							
1	09 15 000 6122	09 15 000 6222																							
1,5	09 15 000 6121	09 15 000 6221																							
2,5	09 15 000 6126	09 15 000 6226																							

## Details

61 03 000 0143 only for modules with one cable entry

Modu-  
lar

Identification	Cable diameter (mm)	Part number	Drawing (dimensions in mm)
----------------	---------------------	-------------	----------------------------

Cable clamp



5 ... 7  
7 ... 10  
9 ... 12

61 03 000 0141  
61 03 000 0044  
61 03 000 0143

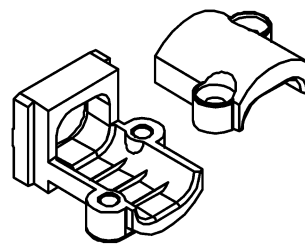





## Details

HARTING offers to test and define the best crimp flange and ferrule combination for customer specific cables.

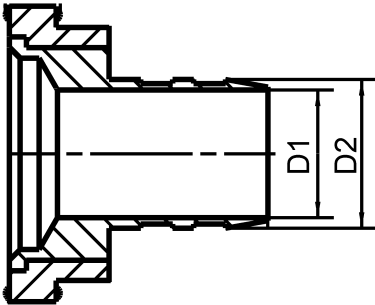
Modular

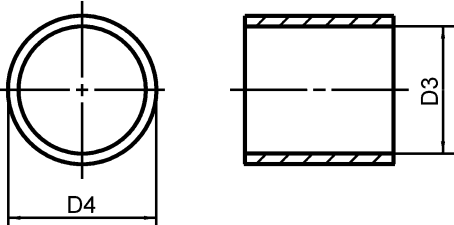
Identification	Inner diameter	Outer diameter	Part number	Drawing (dimensions in mm)		
D-Sub , Crimp flange, D-Sub 9 ... 37  	3 mm	4 mm	61 03 000 0062	 D1 = Inner diameter D2 = Outer diameter		
	3.5 mm	4.5 mm	61 03 000 0063			
	4 mm	5 mm	61 03 000 0064			
	4.5 mm	5.5 mm	61 03 000 0065			
	5 mm	6 mm	61 03 000 0066			
	5.5 mm	6.5 mm	61 03 000 0166			
	6 mm	7 mm	61 03 000 0067			
	6.5 mm	7.5 mm	61 03 000 0068			
	7 mm	8 mm	61 03 000 0069			
	7.5 mm	8.5 mm	61 03 000 0070			
	8 mm	9 mm	61 03 000 0071			
	8.5 mm	9.5 mm	61 03 000 0165			
	9 mm	10 mm	61 03 000 0072			
	D-Sub , Crimp ferrule  	5 mm	6 mm		61 03 000 0045	 D4 = Outer diameter D3 = Inner diameter
		5.5 mm	6.5 mm		61 03 000 0046	
6 mm		7 mm	61 03 000 0047			
6.5 mm		7.5 mm	61 03 000 0048			
7 mm		8 mm	61 03 000 0049			
7.5 mm		8.5 mm	61 03 000 0050			
8 mm		9 mm	61 03 000 0051			
8.5 mm		9.5 mm	61 03 000 0052			
9 mm		10 mm	61 03 000 0053			
9.5 mm		10.5 mm	61 03 000 0054			
10 mm		11 mm	61 03 000 0055			
10.5 mm		11.5 mm	61 03 000 0056			
11 mm		12 mm	61 03 000 0057			
11.5 mm		12.5 mm	61 03 000 0058			
12 mm		13 mm	61 03 000 0142			
12.5 mm		13.5 mm	61 03 000 0059			
13 mm		14 mm	61 03 000 0127			
13.7 mm		15 mm	61 03 000 0060			
14 mm	15 mm	61 03 000 0061				

## Features

- Shielding bus separate from housing potential
- Suitable for the transmission of sensitive signals (e.g. bus signals)
- The four pole Han® Quintax contact is suitable for Ethernet cat. 5e and PROFIBUS when diagonally wiring of the data pairs.

## Technical characteristics

Number of contacts	4
Additional contacts	+ shielding
Electrical data acc. to IEC 61984	10 A 50 V 0,8 kV 3
Rated current	10 A
Rated voltage	50 V
Rated impulse voltage	0.8 kV
Pollution degree	3
Insulation resistance	≥10 <sup>10</sup> Ω
Contact resistance	≤3 mΩ
Limiting temperature	-40 ... +85 °C
Flammability acc. to UL 94	V-0
Mating cycles	≥500
Material (insert)	Polycarbonate, Zinc alloy
Colour (insert)	RAL 7032 (pebble grey)
Material (contacts)	Copper alloy
Material (accessories)	Metal

## Specifications and approvals

EN 60664-1  
IEC 61984  
UL 1977 ECBT2.E235076







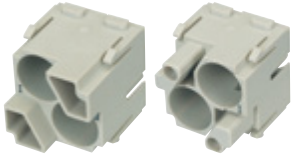
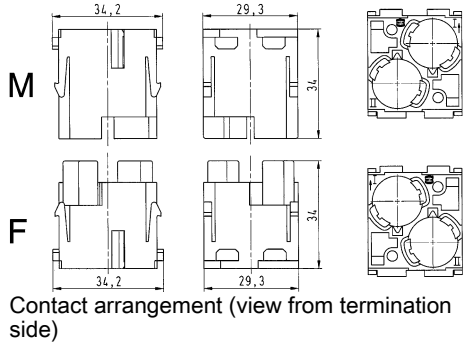

## Details

**Crimping tools** see chapter 90

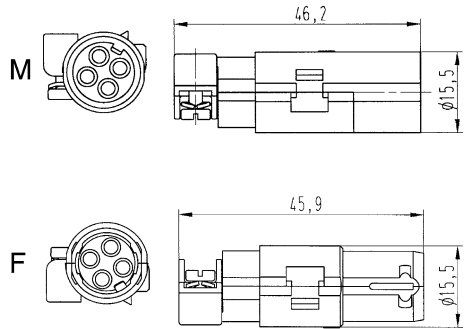
### Remarks on the crimp technique

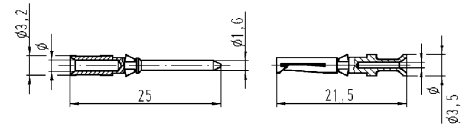
The wire gauges mentioned in the catalogue refer to geometric wire gauges of cables.

Identification	Conductor cross-section (mm <sup>2</sup> )	Part number		Drawing (dimensions in mm)																					
		Male	Female																						
Han-Modular®, Han-Quintax® module, Crimp termination 		09 14 002 3001	09 14 002 3101																						
Han-Quintax®, for Han D® crimp contacts Please order crimp contacts separately. 	0,14 ... 2,5	09 15 004 3013	09 15 004 3113																						
Han D®, Crimp contact, Contact surface: Gold plated 	0,14 ... 0,37 0,5 0,75 1 1,5 2,5	09 15 000 6124 09 15 000 6123 09 15 000 6125 09 15 000 6122 09 15 000 6121 09 15 000 6126	09 15 000 6224 09 15 000 6223 09 15 000 6225 09 15 000 6222 09 15 000 6221 09 15 000 6226	 <table border="1" data-bbox="991 1592 1455 1756"> <thead> <tr> <th>Wire gauge</th> <th>∅</th> <th>Stripping length</th> </tr> </thead> <tbody> <tr> <td>0.14-0.37 mm<sup>2</sup> AWG 26-22</td> <td>0.9 mm</td> <td>8 mm</td> </tr> <tr> <td>0.5 mm<sup>2</sup> AWG 20</td> <td>1.1 mm</td> <td>8 mm</td> </tr> <tr> <td>0.75 mm<sup>2</sup> AWG 18</td> <td>1.3 mm</td> <td>8 mm</td> </tr> <tr> <td>1 mm<sup>2</sup> AWG 18</td> <td>1.45 mm</td> <td>8 mm</td> </tr> <tr> <td>1.5 mm<sup>2</sup> AWG 16</td> <td>1.75 mm</td> <td>8 mm</td> </tr> <tr> <td>2.5 mm<sup>2</sup> AWG 14</td> <td>2.25 mm</td> <td>6 mm</td> </tr> </tbody> </table>	Wire gauge	∅	Stripping length	0.14-0.37 mm <sup>2</sup> AWG 26-22	0.9 mm	8 mm	0.5 mm <sup>2</sup> AWG 20	1.1 mm	8 mm	0.75 mm <sup>2</sup> AWG 18	1.3 mm	8 mm	1 mm <sup>2</sup> AWG 18	1.45 mm	8 mm	1.5 mm <sup>2</sup> AWG 16	1.75 mm	8 mm	2.5 mm <sup>2</sup> AWG 14	2.25 mm	6 mm
Wire gauge	∅	Stripping length																							
0.14-0.37 mm <sup>2</sup> AWG 26-22	0.9 mm	8 mm																							
0.5 mm <sup>2</sup> AWG 20	1.1 mm	8 mm																							
0.75 mm <sup>2</sup> AWG 18	1.3 mm	8 mm																							
1 mm <sup>2</sup> AWG 18	1.45 mm	8 mm																							
1.5 mm <sup>2</sup> AWG 16	1.75 mm	8 mm																							
2.5 mm <sup>2</sup> AWG 14	2.25 mm	6 mm																							
Han-Quintax®, Adapter 		09 14 000 9915	09 14 000 9915																						
Optional																									

## Technical characteristics

Number of contacts	8
Additional contacts	+ shielding
Electrical data acc. to IEC 61984	5 A 50 V 0,8 kV 3
Rated current	5 A
Rated voltage	50 V
Rated impulse voltage	0.8 kV
Pollution degree	3
Insulation resistance	≥10 <sup>10</sup> Ω
Limiting temperature	-40 ... +85 °C
Flammability acc. to UL 94	V-0
Mating cycles	≥500

Modu-  
lar





## Technical characteristics

Material (insert)	Polycarbonate, Zinc alloy
Colour (insert)	RAL 7032 (pebble grey)
Material (contacts)	Copper alloy
Material (accessories)	Metal

## Specifications and approvals

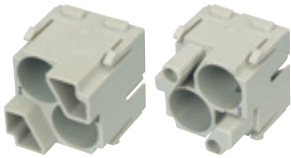
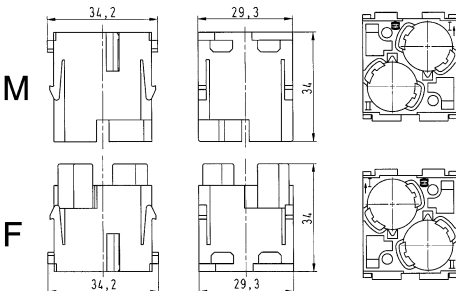
EN 60664-1  
IEC 61984  
UL 1977 ECBT2.E235076

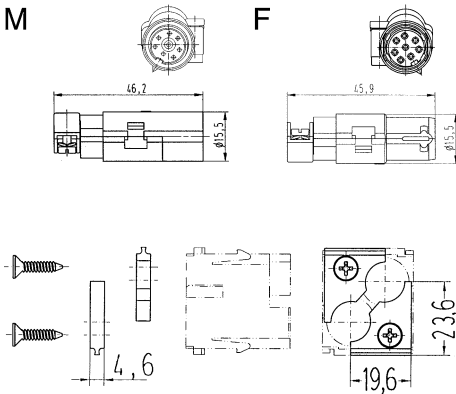

Identification	Conductor cross-section (mm <sup>2</sup> )	Part number		Drawing (dimensions in mm)												
		Male	Female													
Han-Modular®, Han-Quintax® module, Crimp termination 		09 14 002 3001	09 14 002 3101	 <p>M</p> <p>F</p> <p>Contact arrangement (view from termination side)</p>												
Han-Quintax® High Density , for Han® D-Sub crimp contacts  <p>Please order crimp contacts separately.</p> Han-Quintax®, Adapter  <p>Optional</p> D-Sub , Crimp contact, Turned , Pack contents: Single contact 	0,09 ... 0,52	09 15 008 3013	09 15 008 3113	 <p>M</p> <p>F</p>												
	0,09 ... 0,25 0,13 ... 0,33 0,25 ... 0,52	09 67 000 7576 09 67 000 5576 09 67 000 8576	09 67 000 7476 09 67 000 5476 09 67 000 8476	<table border="1"> <thead> <tr> <th>Wire gauge</th> <th>max. insulation diameter</th> <th>Stripping length</th> </tr> </thead> <tbody> <tr> <td>0.09-0.25 mm<sup>2</sup></td> <td>1.7</td> <td>4 mm</td> </tr> <tr> <td>0.13-0.33 mm<sup>2</sup></td> <td>1.7</td> <td>4 mm</td> </tr> <tr> <td>0.25-0.52 mm<sup>2</sup></td> <td>1.7</td> <td>4 mm</td> </tr> </tbody> </table>	Wire gauge	max. insulation diameter	Stripping length	0.09-0.25 mm <sup>2</sup>	1.7	4 mm	0.13-0.33 mm <sup>2</sup>	1.7	4 mm	0.25-0.52 mm <sup>2</sup>	1.7	4 mm
Wire gauge	max. insulation diameter	Stripping length														
0.09-0.25 mm <sup>2</sup>	1.7	4 mm														
0.13-0.33 mm <sup>2</sup>	1.7	4 mm														
0.25-0.52 mm <sup>2</sup>	1.7	4 mm														

## Technical characteristics

Number of contacts	1
Additional contacts	+ shielding
Electrical data acc. to IEC 61984	10 A 50 V 0,8 kV 3
Rated current	10 A
Rated voltage	50 V
Rated impulse voltage	0.8 kV
Pollution degree	3
Insulation resistance	$\geq 10^{10} \Omega$
Contact resistance	$\leq 3 \text{ m}\Omega$
Impedance	75 $\Omega$
Limiting temperature	-40 ... +85 °C
Flammability acc. to UL 94	V-0
Mating cycles	$\geq 500$
Material (insert)	Polycarbonate, Zinc alloy
Colour (insert)	RAL 7032 (pebble grey)
Material (contacts)	Copper alloy

## Specifications and approvals

EN 60664-1  
IEC 61984  
UL 1977 ECBT2.E235076







## Details

**Crimping tools** see chapter 90

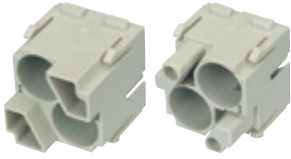
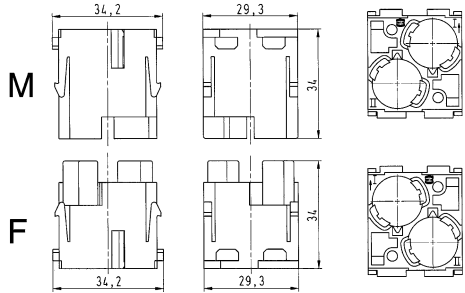
### Remarks on the crimp technique

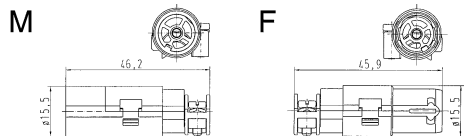
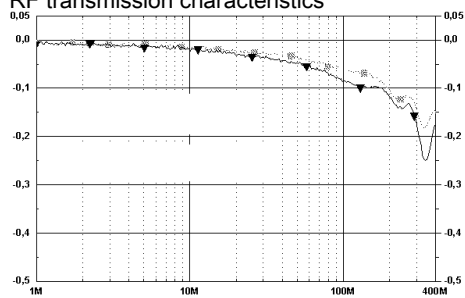
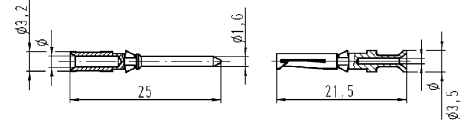
The wire gauges mentioned in the catalogue refer to geometric wire gauges of cables.

Identification	Conductor cross-section (mm <sup>2</sup> )	Part number		Drawing (dimensions in mm)																					
		Male	Female																						
Han-Modular®, Han-Quintax® module, Crimp termination 		09 14 002 3001	09 14 002 3101	 <p>M</p> <p>F</p> <p>Contact arrangement (view from termination side)</p>																					
Han® D Coax , for Han D® crimp contacts  Please order crimp contacts separately.	0,14 ... 2,5	09 15 001 3013	09 15 001 3113	 <p>M</p> <p>F</p> <p>RF transmission characteristics</p>  <p>■ 75 Ohm Cable ▼ 75 Ohm Cable with Han D® Coax</p>  <table border="1"> <thead> <tr> <th>Wire gauge</th> <th>∅</th> <th>Stripping length</th> </tr> </thead> <tbody> <tr> <td>0.14-0.37 mm<sup>2</sup> AWG 26-22</td> <td>0.9 mm</td> <td>8 mm</td> </tr> <tr> <td>0.5 mm<sup>2</sup> AWG 20</td> <td>1.1 mm</td> <td>8 mm</td> </tr> <tr> <td>0.75 mm<sup>2</sup> AWG 18</td> <td>1.3 mm</td> <td>8 mm</td> </tr> <tr> <td>1 mm<sup>2</sup> AWG 18</td> <td>1.45 mm</td> <td>8 mm</td> </tr> <tr> <td>1.5 mm<sup>2</sup> AWG 16</td> <td>1.75 mm</td> <td>8 mm</td> </tr> <tr> <td>2.5 mm<sup>2</sup> AWG 14</td> <td>2.25 mm</td> <td>6 mm</td> </tr> </tbody> </table>	Wire gauge	∅	Stripping length	0.14-0.37 mm <sup>2</sup> AWG 26-22	0.9 mm	8 mm	0.5 mm <sup>2</sup> AWG 20	1.1 mm	8 mm	0.75 mm <sup>2</sup> AWG 18	1.3 mm	8 mm	1 mm <sup>2</sup> AWG 18	1.45 mm	8 mm	1.5 mm <sup>2</sup> AWG 16	1.75 mm	8 mm	2.5 mm <sup>2</sup> AWG 14	2.25 mm	6 mm
Wire gauge	∅	Stripping length																							
0.14-0.37 mm <sup>2</sup> AWG 26-22	0.9 mm	8 mm																							
0.5 mm <sup>2</sup> AWG 20	1.1 mm	8 mm																							
0.75 mm <sup>2</sup> AWG 18	1.3 mm	8 mm																							
1 mm <sup>2</sup> AWG 18	1.45 mm	8 mm																							
1.5 mm <sup>2</sup> AWG 16	1.75 mm	8 mm																							
2.5 mm <sup>2</sup> AWG 14	2.25 mm	6 mm																							
Han D®, Crimp contact, Contact surface: Gold plated 	0,14 ... 0,37 0,5 0,75 1 1,5 2,5	09 15 000 6124 09 15 000 6123 09 15 000 6125 09 15 000 6122 09 15 000 6121 09 15 000 6126	09 15 000 6224 09 15 000 6223 09 15 000 6225 09 15 000 6222 09 15 000 6221 09 15 000 6226																						

## Technical characteristics

Number of contacts	1
Additional contacts	+ shielding
Electrical data acc. to IEC 61984	16 A 50 V 0,8 kV 3
Rated current	16 A
Rated voltage	50 V
Rated impulse voltage	0.8 kV
Pollution degree	3
Insulation resistance	≥10 <sup>10</sup> Ω
Contact resistance	≤1 mΩ
Impedance	50 Ω
Limiting temperature	-40 ... +85 °C
Flammability acc. to UL 94	V-0
Mating cycles	≥500
Material (insert)	Polycarbonate, Zinc alloy
Colour (insert)	RAL 7032 (pebble grey)
Material (contacts)	Copper alloy

## Specifications and approvals

EN 60664-1  
IEC 61984  
UL 1977 ECBT2.E235076







## Details

**Crimping tools** see chapter 90

### Remarks on the crimp technique

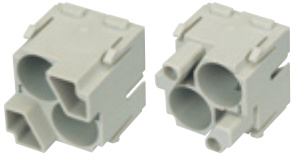
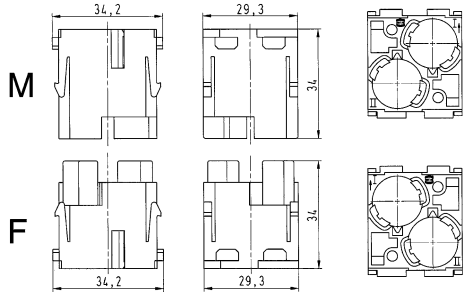
The wire gauges mentioned in the catalogue refer to geometric wire gauges of cables.

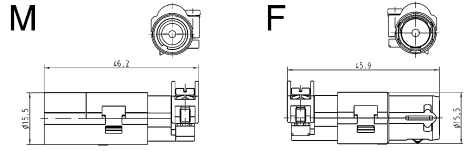
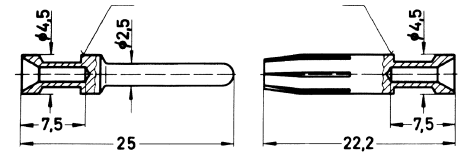

Identification	Conductor cross-section (mm <sup>2</sup> )	Part number		Drawing (dimensions in mm)																																																			
		Male	Female																																																				
Han-Modular®, Han-Quintax® module, Crimp termination 		09 14 002 3001	09 14 002 3101	 <p>Contact arrangement (view from termination side)</p>																																																			
Han® E Coax , for Han E® crimp contacts  <p>Please order crimp contacts separately.</p>	0,14 ... 5,5	09 15 001 3023	09 15 001 3123	 <table border="1" data-bbox="986 1227 1453 1310"> <thead> <tr> <th>Han E® Coax with RG 213 cable (2.5 mm<sup>2</sup>)</th> <th>200 MHz</th> <th>500 MHz</th> <th>1.0 GHz</th> <th>1.2 GHz</th> <th>1.5 GHz</th> <th>2.0 GHz</th> <th>2.5 GHz</th> </tr> </thead> <tbody> <tr> <td>Return loss [dB]</td> <td>23.8</td> <td>21.1</td> <td>&gt;16.7</td> <td>&gt;17.7</td> <td>&gt;16.4</td> <td>&gt;14.1</td> <td>&gt;12.0</td> </tr> <tr> <td>Attenuation [dB]</td> <td>0.07</td> <td>0.11</td> <td>0.17</td> <td>0.2</td> <td>&lt;0.23</td> <td>&lt;0.53</td> <td>&lt;2.0</td> </tr> </tbody> </table>  <table border="1" data-bbox="986 1541 1453 1825"> <thead> <tr> <th>Conductor cross-section</th> <th>AWG</th> <th>Identification</th> </tr> </thead> <tbody> <tr> <td>0.14-0.37 mm<sup>2</sup></td> <td>AWG 26-22</td> <td>no groove</td> </tr> <tr> <td>0.5 mm<sup>2</sup></td> <td>AWG 20</td> <td>no groove</td> </tr> <tr> <td>0.75 mm<sup>2</sup></td> <td>AWG 18</td> <td>1 groove*</td> </tr> <tr> <td>1 mm<sup>2</sup></td> <td>AWG 18</td> <td>1 groove</td> </tr> <tr> <td>1.5 mm<sup>2</sup></td> <td>AWG 16</td> <td>2 grooves</td> </tr> <tr> <td>2.5 mm<sup>2</sup></td> <td>AWG 14</td> <td>3 grooves</td> </tr> <tr> <td>3 mm<sup>2</sup></td> <td>AWG 12</td> <td>wide groove</td> </tr> <tr> <td>4 mm<sup>2</sup></td> <td>AWG 12</td> <td>no groove</td> </tr> </tbody> </table> <p>* on the back crimp collar Stripping length 7.5 mm</p>	Han E® Coax with RG 213 cable (2.5 mm <sup>2</sup> )	200 MHz	500 MHz	1.0 GHz	1.2 GHz	1.5 GHz	2.0 GHz	2.5 GHz	Return loss [dB]	23.8	21.1	>16.7	>17.7	>16.4	>14.1	>12.0	Attenuation [dB]	0.07	0.11	0.17	0.2	<0.23	<0.53	<2.0	Conductor cross-section	AWG	Identification	0.14-0.37 mm <sup>2</sup>	AWG 26-22	no groove	0.5 mm <sup>2</sup>	AWG 20	no groove	0.75 mm <sup>2</sup>	AWG 18	1 groove*	1 mm <sup>2</sup>	AWG 18	1 groove	1.5 mm <sup>2</sup>	AWG 16	2 grooves	2.5 mm <sup>2</sup>	AWG 14	3 grooves	3 mm <sup>2</sup>	AWG 12	wide groove	4 mm <sup>2</sup>	AWG 12	no groove
Han E® Coax with RG 213 cable (2.5 mm <sup>2</sup> )	200 MHz	500 MHz	1.0 GHz	1.2 GHz	1.5 GHz	2.0 GHz	2.5 GHz																																																
Return loss [dB]	23.8	21.1	>16.7	>17.7	>16.4	>14.1	>12.0																																																
Attenuation [dB]	0.07	0.11	0.17	0.2	<0.23	<0.53	<2.0																																																
Conductor cross-section	AWG	Identification																																																					
0.14-0.37 mm <sup>2</sup>	AWG 26-22	no groove																																																					
0.5 mm <sup>2</sup>	AWG 20	no groove																																																					
0.75 mm <sup>2</sup>	AWG 18	1 groove*																																																					
1 mm <sup>2</sup>	AWG 18	1 groove																																																					
1.5 mm <sup>2</sup>	AWG 16	2 grooves																																																					
2.5 mm <sup>2</sup>	AWG 14	3 grooves																																																					
3 mm <sup>2</sup>	AWG 12	wide groove																																																					
4 mm <sup>2</sup>	AWG 12	no groove																																																					
Han E®, Crimp contact, Contact surface: Gold plated 	0,14 ... 0,37 0,5 0,75 1 1,5 2,5 4	09 33 000 6117 09 33 000 6122 09 33 000 6115 09 33 000 6118 09 33 000 6116 09 33 000 6123 09 33 000 6119	09 33 000 6217 09 33 000 6222 09 33 000 6215 09 33 000 6218 09 33 000 6216 09 33 000 6223 09 33 000 6221																																																				

Number of contacts

# 4

1,5 A 50 V

## Features

- Suitable for FOC and coaxial contacts acc. to EN 41626 / D-Sub

## Technical characteristics

Number of contacts	4
Electrical data acc. to IEC 61984	1,5 A 50 V
Rated current	1.5 A
Rated voltage	50 V
Insulation resistance	$\geq 10^{10} \Omega$
Contact resistance	$\leq 10 \text{ m}\Omega$
Impedance	50 $\Omega$ , 75 $\Omega$
Limiting temperature	-40 ... +125 °C
Flammability acc. to UL 94	V-0
Mating cycles	$\geq 500$
Material (insert)	Polycarbonate
Colour (insert)	RAL 7032 (pebble grey)
Material (contacts)	Copper alloy

## Specifications and approvals

EN 60664-1  
IEC 61984





## Details

ATTENTION when using coaxial contacts:

Male module 09 14 004 4501 with male contacts 09 14 000 62xx

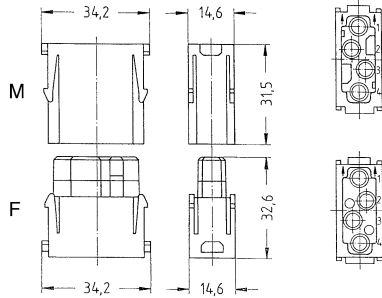
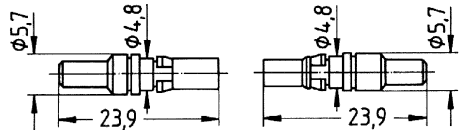
Female module 09 14 004 4512 with female contacts 09 14 000 61xx

Identification	Part number		Drawing (dimensions in mm)
	Male	Female	
<p>Han-Modular®, Han® Multi module</p>  <p>Please order contacts separately. When removing the contacts, the two-piece module can be opened using a 7mm screwdriver. This destroys the module.</p>	09 14 004 4501	09 14 004 4512	 <p>Contact arrangement (view from termination side)</p> 
<p>DIN 41626, Coaxial contact, Solder/crimp termination, 50 Ohm, Contact resistance <math>\leq 10 \text{ m}\Omega</math> Contact surface: Gold plated</p> 	09 14 000 6211	09 14 000 6111	

Modular

Identification	Part number		Drawing (dimensions in mm)																																																					
	Male	Female																																																						
DIN 41626 , Coaxial contact, Solder/crimp termination, 75 Ohm, Contact resistance ≤ 10 mOhm Contact surface: Gold plated	09 14 000 6221	09 14 000 6121	<table border="1"> <thead> <tr> <th rowspan="2">Wires</th> <th>Shell</th> <th>Internal wire</th> <th colspan="3">Dämpfung db/100 m bei</th> </tr> <tr> <th>mm</th> <th>mm</th> <th>100MHz</th> <th>200MHz</th> <th>800MHz</th> </tr> </thead> <tbody> <tr> <td>50 Ω</td> <td></td> <td></td> <td></td> <td></td> <td></td> </tr> <tr> <td>RG 174 / U</td> <td>2.5</td> <td>0.48</td> <td></td> <td></td> <td>84</td> </tr> <tr> <td>RG 188 A / U</td> <td>2.6</td> <td>0.54</td> <td>29</td> <td>40</td> <td></td> </tr> <tr> <td>RG 316 / U</td> <td>2.5</td> <td>0.54</td> <td></td> <td>40</td> <td></td> </tr> <tr> <td>75 Ω</td> <td></td> <td></td> <td></td> <td></td> <td></td> </tr> <tr> <td>RG 179 B / U</td> <td>2.55</td> <td>0.3</td> <td></td> <td>41</td> <td></td> </tr> <tr> <td>RG 187 A / U</td> <td>2.7</td> <td>0.3</td> <td></td> <td>41</td> <td></td> </tr> </tbody> </table>	Wires	Shell	Internal wire	Dämpfung db/100 m bei			mm	mm	100MHz	200MHz	800MHz	50 Ω						RG 174 / U	2.5	0.48			84	RG 188 A / U	2.6	0.54	29	40		RG 316 / U	2.5	0.54		40		75 Ω						RG 179 B / U	2.55	0.3		41		RG 187 A / U	2.7	0.3		41	
Wires	Shell	Internal wire	Dämpfung db/100 m bei																																																					
	mm	mm	100MHz	200MHz	800MHz																																																			
50 Ω																																																								
RG 174 / U	2.5	0.48			84																																																			
RG 188 A / U	2.6	0.54	29	40																																																				
RG 316 / U	2.5	0.54		40																																																				
75 Ω																																																								
RG 179 B / U	2.55	0.3		41																																																				
RG 187 A / U	2.7	0.3		41																																																				
DIN 41626 , FO contact, for 1 mm plastic fibre	20 10 001 4211	20 10 001 4221																																																						
DIN 41626 , FO contact, for SI fibre (HCS®) 200/230 µm	20 10 230 4211	20 10 230 4221																																																						
DIN 41626 , FO contact, for GI fibre 50/125 µm for ceramic ferrule 62.5/125 µm	20 10 125 4212	20 10 125 4222																																																						

Modu-  
lar

Number of contacts

# 4

1,5 A 50 V

## Features

- Suitable for FOC and coaxial contacts acc. to EN 41626 / D-Sub

## Technical characteristics

Number of contacts	4
Electrical data acc. to IEC 61984	1,5 A 50 V
Rated current	1.5 A
Rated voltage	50 V
Insulation resistance	$\geq 10^{10} \Omega$
Contact resistance	$\leq 6 \text{ m}\Omega, \leq 10 \text{ m}\Omega$
Impedance	50 $\Omega$ , 75 $\Omega$
Limiting temperature	-40 ... +125 °C
Flammability acc. to UL 94	V-0
Mating cycles	$\geq 500$
Nominal frequency	50 Hz
Material (insert)	Polycarbonate
Colour (insert)	RAL 7032 (pebble grey)
Material (locking)	Copper alloy
Material (contacts)	Copper alloy, PBFE / PBTP / PI

## Specifications and approvals

EN 60664-1  
IEC 61984





## Details



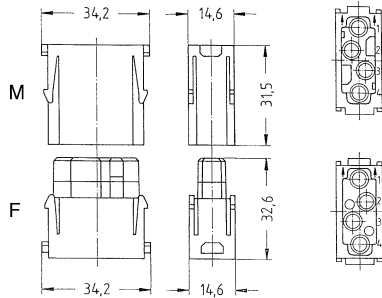
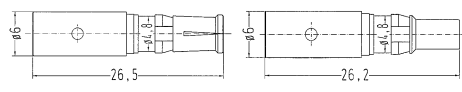

ATTENTION when using coaxial contacts:

Male module 09 14 004 4501 with male contacts 09 14 000 62xx or 09 69 28x 5xxx

Female module 09 14 004 4513 with female contacts 09 14 000 61xx or 09 69 18x 5xxx

Identification	Part number		Drawing (dimensions in mm)
	Male	Female	
<p>Han-Modular®, Han® Multi module</p>  <p>Please order contacts separately. When removing the contacts, the two-piece module can be opened using a 7mm screwdriver. This destroys the module.</p>	09 14 004 4501	09 14 004 4513	 <p>Contact arrangement (view from termination side)</p> 
<p>D-Sub , Coaxial contact, Solder / solder termination, 50 Ohm, Contact resistance <math>\leq 6 \text{ m}\Omega</math> Contact surface: Gold plated</p> 	09 14 000 6215	09 14 000 6115	

Modular

Identification	Part number		Drawing (dimensions in mm)
	Male	Female	
D-Sub , Coaxial contact, Crimp/crimp termination, Straight Turned for cables RG 174 U, 188 AU, 316 U , 50 Ohm, Contact resistance $\leq 10$ mOhm Contact surface: Gold plated	09 69 282 5140	09 69 182 5140	
			
D-Sub , Coaxial contact, Crimp/crimp termination, Straight Turned for cables RG 179 BU, 187 AU , 75 Ohm, Contact resistance $\leq 10$ mOhm Contact surface: Gold plated	09 69 282 5230	09 69 182 5230	
			
D-Sub , Coaxial contact, Solder/crimp termination, Straight Turned for cables RG 174 U, 188 AU, 316 U , 50 Ohm, Contact resistance $\leq 10$ mOhm Contact surface: Gold plated	09 69 281 5140	09 69 181 5140	
			
D-Sub , Coaxial contact, Solder/crimp termination, Straight Turned for cables RG 178 BU, 196 AU, 404 U , 75 Ohm, Contact resistance $\leq 10$ mOhm Contact surface: Gold plated	09 69 281 5141	09 69 181 5141	
			
D-Sub , Coaxial contact, Solder/crimp termination, Straight Turned for cables RG 58 CU, 141 AU , 50 Ohm, Contact resistance $\leq 10$ mOhm Contact surface: Gold plated	09 69 281 5143	09 69 181 5143	
			

Identification	Part number		Drawing (dimensions in mm)
	Male	Female	
D-Sub , Coaxial contact, Solder/crimp termination, Straight Turned for cables RG 179 BU, 187 AU , 75 Ohm, Contact resistance ≤ 10 mOhm Contact surface: Gold plated	09 69 281 5230	09 69 181 5230	



Modu-  
lar

Number of contacts

# 12

1,5 A 50 V

## Technical characteristics

Number of contacts	12
Electrical data acc. to IEC 61984	1,5 A 50 V
Rated current	1.5 A
Rated voltage	50 V
Insulation resistance	$\geq 10^{10} \Omega$
Contact resistance	$\leq 10 \text{ m}\Omega$
Impedance	50 $\Omega$ , 75 $\Omega$
Limiting temperature	-40 ... +125 °C
Flammability acc. to UL 94	V-0
Mating cycles	$\geq 500$
Material (insert)	Polycarbonate
Colour (insert)	RAL 7032 (pebble grey)
Material (contacts)	Copper alloy

## Specifications and approvals

EN 60664-1  
IEC 61984



## Details



ATTENTION! Guide pins and bushes are prescribed (see chapter 80).

ATTENTION when using coaxial contacts:

Male module 09 14 012 4501 with male contacts 09 14 000 62xx

Female module 09 14 012 4512 with female contacts 09 14 000 61xx

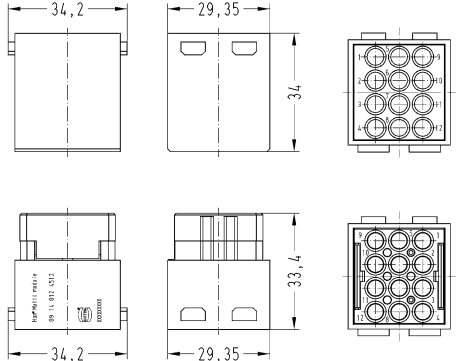
Modu-  
lar

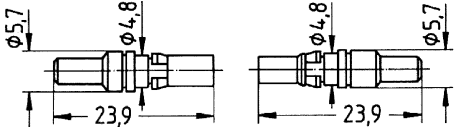
Identification	Part number		Drawing (dimensions in mm)
	Male	Female	
<p>Han-Modular®, Han® Multi module, acc. to DIN 41626</p>  <p>Please order contacts separately. Due to the closed entry design of female insert the upper part has to be removed by screw driver before extracting the contacts.</p>	09 14 012 4501	09 14 012 4512	 <p>Contact arrangement (view from termination side)</p>
<p>DIN 41626 , Coaxial contact, Solder/crimp termination, 50 Ohm, Contact resistance <math>\leq 10 \text{ m}\Omega</math> Contact surface: Gold plated</p> 	09 14 000 6211	09 14 000 6111	

Identification	Part number		Drawing (dimensions in mm)																																																					
	Male	Female																																																						
DIN 41626 , Coaxial contact, Solder/crimp termination, 75 Ohm, Contact resistance ≤ 10 mOhm Contact surface: Gold plated	09 14 000 6221	09 14 000 6121	<table border="1"> <thead> <tr> <th rowspan="2">Wires</th> <th>Shell</th> <th>Internal wire</th> <th colspan="3">Dämpfung db/100 m bei</th> </tr> <tr> <th>mm</th> <th>mm</th> <th>100MHz</th> <th>200MHz</th> <th>800MHz</th> </tr> </thead> <tbody> <tr> <td>50 Ω</td> <td></td> <td></td> <td></td> <td></td> <td></td> </tr> <tr> <td>RG 174 / U</td> <td>2.5</td> <td>0.48</td> <td></td> <td></td> <td>84</td> </tr> <tr> <td>RG 188 A / U</td> <td>2.6</td> <td>0.54</td> <td>29</td> <td>40</td> <td></td> </tr> <tr> <td>RG 316 / U</td> <td>2.5</td> <td>0.54</td> <td></td> <td>40</td> <td></td> </tr> <tr> <td>75 Ω</td> <td></td> <td></td> <td></td> <td></td> <td></td> </tr> <tr> <td>RG 179 B / U</td> <td>2.55</td> <td>0.3</td> <td></td> <td>41</td> <td></td> </tr> <tr> <td>RG 187 A / U</td> <td>2.7</td> <td>0.3</td> <td></td> <td>41</td> <td></td> </tr> </tbody> </table>	Wires	Shell	Internal wire	Dämpfung db/100 m bei			mm	mm	100MHz	200MHz	800MHz	50 Ω						RG 174 / U	2.5	0.48			84	RG 188 A / U	2.6	0.54	29	40		RG 316 / U	2.5	0.54		40		75 Ω						RG 179 B / U	2.55	0.3		41		RG 187 A / U	2.7	0.3		41	
Wires	Shell	Internal wire	Dämpfung db/100 m bei																																																					
	mm	mm	100MHz	200MHz	800MHz																																																			
50 Ω																																																								
RG 174 / U	2.5	0.48			84																																																			
RG 188 A / U	2.6	0.54	29	40																																																				
RG 316 / U	2.5	0.54		40																																																				
75 Ω																																																								
RG 179 B / U	2.55	0.3		41																																																				
RG 187 A / U	2.7	0.3		41																																																				
DIN 41626 , FO contact, for 1 mm plastic fibre	20 10 001 4211	20 10 001 4221																																																						
DIN 41626 , FO contact, for SI fibre (HCS®) 200/230 µm	20 10 230 4211	20 10 230 4221																																																						
DIN 41626 , FO contact, for GI fibre 50/125 µm for ceramic ferrule 62.5/125 µm	20 10 125 4212	20 10 125 4222																																																						

Modu-  
lar



## Features

- for the transmission of clean and dry compressed air
- Operating pressure up to 8 bar (116 psi)
- Female contacts with / without shut-off
- Removal of tubes from pre-assembled pneumatic contacts is possible

## Technical characteristics

Number of contacts	2, 3
Limiting temperature	-40 ... +80 °C
Flammability acc. to UL 94	V-0
Mating cycles	≥500
Tube inner diameter	6 mm, 1.6 mm, 3 mm, 4 mm
Material (insert)	Polycarbonate
Colour (insert)	Blue
Material (seal)	Buna-N
Material (contacts)	Delrin acetal

## Specifications and approvals



## Details

### Shut-off principle:

In the disconnected position the spring integrated in the female contact is active, thus the O-ring of the valve seals the opening of the air-way. During the mating process, when the defined depth of insertion is reached the male contact presses on the valve head and moves it backwards against the spring tension, so that the air-way opens.

Using of guiding pins in connection with pneumatic modules is imperative.

In addition to this guiding pins guarantee a coding, if pneumatic modules are used exclusively.

Number of contacts

# 2

Modular

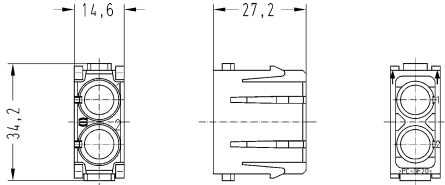
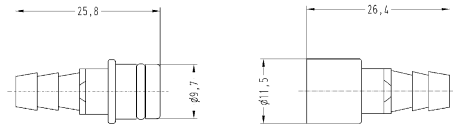
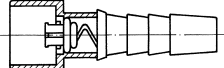
Identification	Part number		Drawing (dimensions in mm)
	Male	Female	
Han-Modular®, Han® Pneumatic module  <p>Please order contacts separately. Using of guiding pins is imperative!</p>	09 14 002 4501	09 14 002 4501	 <p>Contact arrangement (view from termination side)</p>
Pneumatic contact, Without shut-off , 6 mm / 1/4"	09 14 000 6174	09 14 000 6274	 <p>Male contact Female contact</p>
Pneumatic contact, With shut-off Polypropylen, 6 mm / 1/4"		09 14 000 6279	 <p>Female contact with shut-off in closed position</p>

Number of contacts

# 3

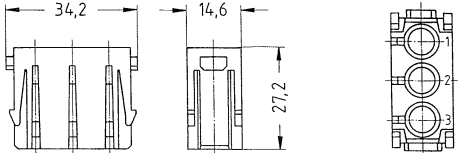
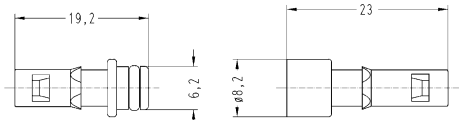
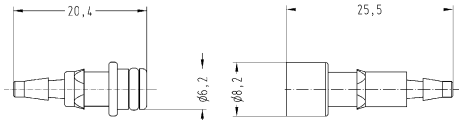
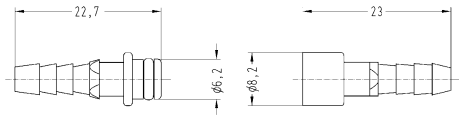
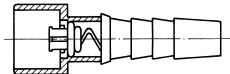
Identification	Part number		Drawing (dimensions in mm)
	Male	Female	
Han-Modular®, Han® Pneumatic module   Please order contacts separately. Using of guiding pins is imperative!	09 14 003 4501	09 14 003 4501	 Contact arrangement (view from termination side)
Pneumatic contact, Without shut-off , 1,6 mm / 1/16"	09 14 000 6151	09 14 000 6251	 Male contact Female contact
Pneumatic contact, Without shut-off , 3 mm	09 14 000 6152	09 14 000 6252	
Pneumatic contact, Without shut-off , 4 mm / 1/8"	09 14 000 6153	09 14 000 6253	
Pneumatic contact, With shut-off Polypropylen, 1,6 mm / 1/16"		09 14 000 6256	 Female contact with shut-off in closed position
Pneumatic contact, With shut-off Polypropylen, 3 mm		09 14 000 6257	
Pneumatic contact, With shut-off Polypropylen, 4 mm / 1/8"		09 14 000 6258	

Modular

## Features

- Suitable for HARTING SC contacts
- for GI-Fibre 50 - 62,5 / 125µm
- Insertion loss < 0.5 dB

## Technical characteristics

Number of contacts	4
Limiting temperature	-40 ... +85 °C
Flammability acc. to UL 94	V-0
Mating cycles	≥500
Material (insert)	Polycarbonate
Colour (insert)	RAL 7032 (pebble grey)

## Specifications and approvals

UL 1977 ECBT2.E235076



## Details

Guide pins and bushes are recommended (see chapter 80).

## Details

### Assembly instructions

#### Male module

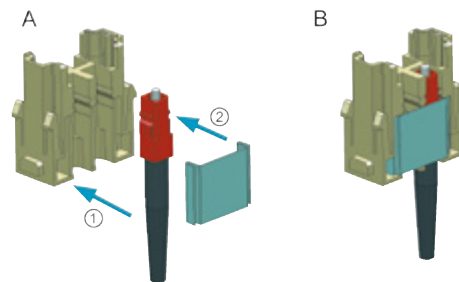

- A) Assemble the SC contact  
 Push the SC contact from the side into the relevant insert ①  
 Push the fixing plate from the side over the contacts ②  
 B) SC contact fixed in the module

### Assembly instructions



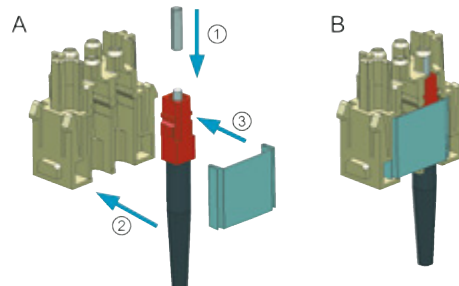

#### Female module



- A) Assemble the SC contact  
 Push the centering ferrule (included in delivery) on the SC contact ①  
 Push the SC contact from the side into the relevant insert ②  
 Push the fixing plate from the side over the contacts ③  
 B) SC contact fixed in the module

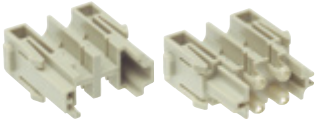
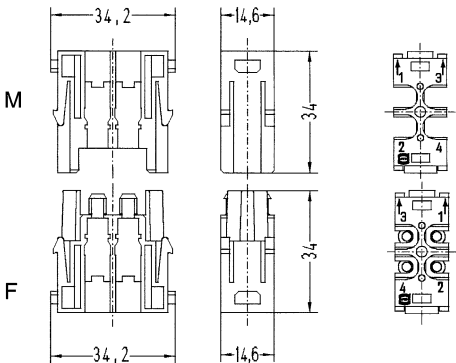

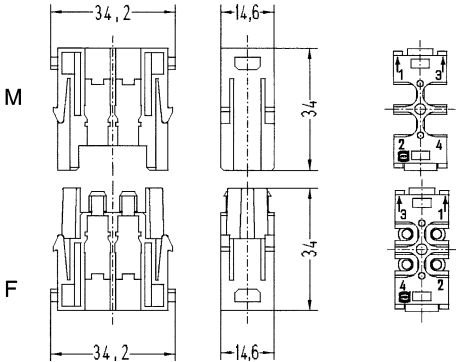

Number of contacts

# 4

Identification	Part number		Drawing (dimensions in mm)
	Male	Female	
Han-Modular®, Han® SC module    Please order contacts separately.	09 14 004 4701	09 14 004 4712	 Contact arrangement (view from termination side)
Han-Modular®, Han® SC module, with ceramic ferrule 62.5/125 µm    Please order contacts separately.		09 14 004 4711	 Contact arrangement (view from termination side)
Han-Modular®, Han® SC module, with metal ferrule    Please order contacts separately.		09 14 004 4713	
SC contact, for 1 mm plastic fibre Crimp termination  	20 10 001 5211	20 10 001 5211	

Modular

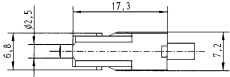
Modu-  
lar

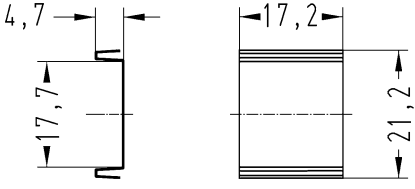
Identification	Part number		Drawing (dimensions in mm)
	Male	Female	
SC contact, for 1 mm plastic fibre IDC termination  	20 10 001 5217	20 10 001 5217	
SC contact, for GI fibre 50/125 µm for ceramic ferrule 62.5/125 µm  	20 10 125 5211	20 10 125 5211	
SC contact, for SI fibre (HCS®) 200/230 µm  	20 10 230 5211	20 10 230 5211	
Han-Modular®, Fixing plate, for SC module  	09 14 000 9965	09 14 000 9965	

## Features

- Suitable for HARTING LC contacts
- for GI-Fibre 50 - 62.5 / 125 µm and for singlemode fibre

## Technical characteristics

Number of contacts	6
Limiting temperature	-40 ... +85 °C
Flammability acc. to UL 94	V-0
Mating cycles	≥500
Material (insert)	Polycarbonate
Colour (insert)	RAL 7032 (pebble grey)



## Details

ATTENTION! Guide pins and bushes are prescribed (see chapter 80).

Number of contacts

# 6

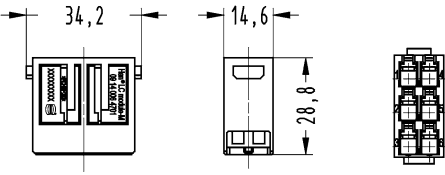
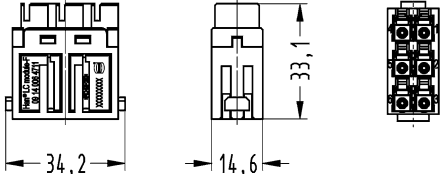
Modular

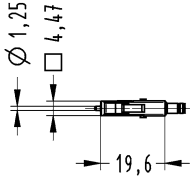
Identification	Part number		Drawing (dimensions in mm)		
	Male	Female			
Han-Modular®, Han® LC module    Please order contacts separately.	09 14 006 4701	09 14 006 4711			
LC contact, Singlemode for wire gauge up to 2 mm	20 10 125 8221	20 10 125 8221			
LC contact, Singlemode for wire gauge up to 3 mm	20 10 125 8220	20 10 125 8220			
LC contact, Multimode for wire gauge up to 2 mm	20 10 125 8212	20 10 125 8212			
LC contact, Multimode for wire gauge up to 3 mm    	20 10 125 8211	20 10 125 8211			



Number of contacts

# 7

## Technical characteristics



Number of contacts	7
Operating temperature	-40 ... +70 °C
Storage temperature	-40 ... +70°C
Mating cycles	≥500
Degree of protection acc. to IEC 60529	IP30
Power consumption	<5 W
Material (insert)	Polycarbonate
Colour (insert)	RAL 7032 (pebble grey)
Material (contacts)	Copper alloy

## Specifications and approvals

DIN EN 60721-3-3  
 DIN EN 50102  
 EN 61000-4-2  
 Electrostatic discharge (ESD)  
 EN 61000-4-3  
 Electromagnetic field  
 EN 61000-4-4  
 Rapid transients (burst)  
 EN 61000-4-5  
 Surge voltages  
 EN 61000-4-6  
 conducted disturbances



Modular

Identification	Part number		Drawing (dimensions in mm)
	Male	Female	
Han-Modular®, ID CAN, Contact surface: Gold plated 	09 80 015 0100		
Han-Modular®, ID CAN, Cage-clamp termination, Contact surface: Gold plated 		09 80 115 0200	

Modu-  
lar

### Technical characteristics

Storage temperature	-40 ... +85°C
Degree of protection acc. to IEC 60529	IP30, When mated
Supply voltage	24 V DC
Transmission characteristics	Category, 5
Data rate	1000 Gbit/s
Material (insert)	Polycarbonate
Colour (insert)	RAL 7032 (pebble grey)

### Specifications and approvals

EN 55022  
 Radio disturbance characteristics  
 EN 61000-4-2  
 Electrostatic discharge (ESD)  
 EN 61000-4-3  
 Electromagnetic field  
 EN 61000-4-4  
 Rapid transients (burst)  
 EN 61000-4-5  
 Surge voltages  
 EN 61000-4-6  
 conducted disturbances  
 EN 61000-6-4  
 emission standard  
 IEC 60068-2-6  
 Vibration (sinusoidal)  
 IEC 60068-2-27  
 Shock  
 IEEE 802.3



Identification	Part number		Drawing (dimensions in mm)
	Male	Female	
Han-Modular®, Switch US4  	09 80 113 0400	09 80 113 0400	

## Features

- Robust housing
- Compact design saves space
- Modular structure increases flexibility
- Simple and quick assembly
- Two-part hood

## Technical characteristics

Limiting temperature	-40 ... +125 °C
Mating cycles	≥500
Degree of protection acc. to IEC 60529	IP65, In locked position
Material (hood/housing)	Zinc die-cast
Surface (hood/housing)	Nickel plated
Material (seal)	NBR
Material (locking)	Stainless steel
Material (accessories)	Metal

## Details

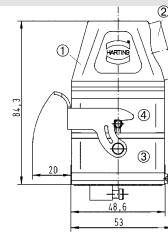





- ① Hood with side entry
- ② Cable entry M25
- ③ Bulkhead mounted housing with locking lever
- ④ Carrier hood

Double locking lever

Modular

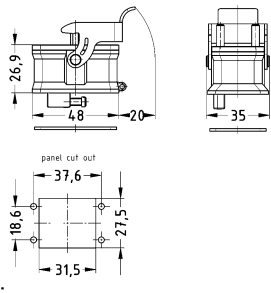
Identification	Cable entry	Conductor cross-section (mm <sup>2</sup> )	Part number	Drawing (dimensions in mm)	
Han-Modular® Compact , Hoods, Top entry, Pack contents: 4 screws are included within the delivery	1x M25 1x M32		19 14 001 0401 19 14 001 0402		
Han-Modular® Compact , Hoods, Side entry, Pack contents: 4 screws are included within the delivery	1x M25		19 14 001 0501		
Han-Modular® Compact , Carrier hood		0,5 ... 10 PE	09 14 001 0311		
Han-Modular® Compact , Protection covers for carrier hoods, Thermoplastic			09 14 001 5402		

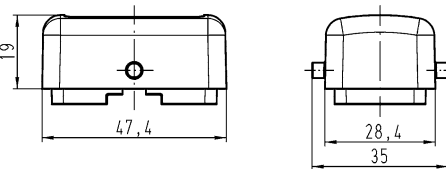
Double locking lever

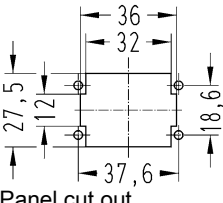
Identification	Conductor cross-section (mm <sup>2</sup> )	Part number	Drawing (dimensions in mm)
<p>Han-Modular® Compact , Bulkhead mounted housings</p> 	<p>0,5 ... 10 PE</p>	<p>09 14 001 0301</p>	
<p>Han-Modular® Compact , Protection cover for bulkhead mounted housings, Thermoplastic</p> 		<p>09 14 001 5401</p>	
<p>Fixing bracket</p> 		<p>09 14 000 9947</p>	

Modular





## Technical characteristics

Material (accessories) Thermoplastic

## Technical characteristics

Colour (accessories) Red, Blue, Black, Yellow

Modular

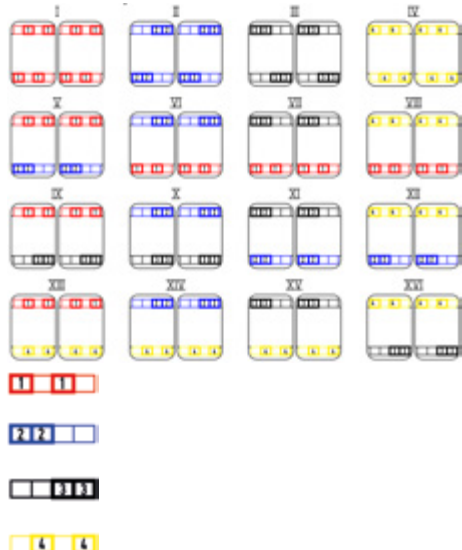
Identification	Part number	Drawing (dimensions in mm)
Coding element, Red 	09 14 000 9971	
Coding element, Blue 	09 14 000 9972	
Coding element, Black 	09 14 000 9973	
Coding element, Yellow 	09 14 000 9974	

## Features

- Robust housing
- Compact design saves space
- Modular structure increases flexibility
- Simple and quick assembly
- Two-part hood

## Technical characteristics

Limiting temperature	-40 ... +125 °C
Flammability acc. to UL 94 (locking levers)	V-0
Mating cycles	≥500
Degree of protection acc. to IEC 60529	IP65
Material (hood/housing)	Aluminium die-cast, Zinc die-cast
Surface (hood/housing)	Powder-coated
Colour (hood/housing)	RAL 7037 (dust grey)
Material (seal)	NBR
Material (locking)	Polycarbonate, Stainless steel
Colour (locking)	RAL 7037 (dust grey)
Material (accessories)	Zinc die-cast

## Details

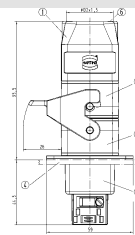





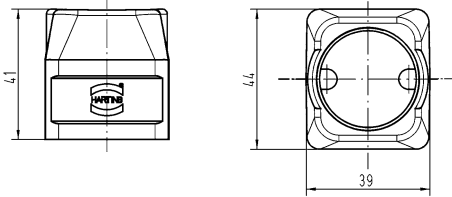

- ① Hood with top entry
- ② Carrier hood
- ③ Bulkhead mounted housing with locking lever
- ④ Switch board panel
- ⑤ Panel feed through housings
- ⑥ Cable entry

Screw locking

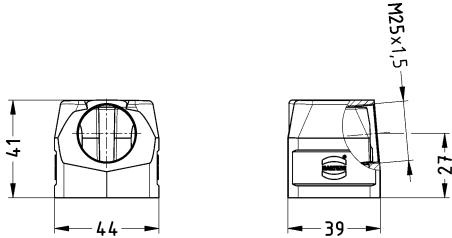

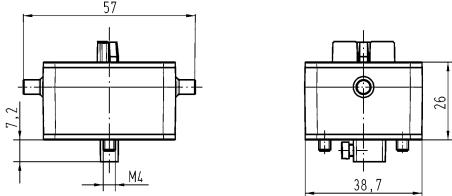
Modular

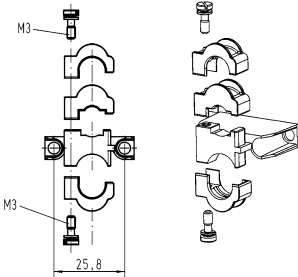
Identification	Cable entry	Conductor cross-section (mm <sup>2</sup> )	Part number	Drawing (dimensions in mm)
Han-Modular® Twin , Hoods, Top entry 	1x M20 1x M25 1x M32		19 14 002 0400 19 14 002 0401 19 14 002 0402	
Han-Modular® Twin , Hoods, Side entry 	1x M25		19 14 002 0501	
Han-Modular® Twin , Carrier hood 		0,5 ... 10 PE	09 14 002 0311	
Han-Modular® Twin , Angled housing, Zinc die-cast 	1x M32		09 14 002 0950 19 14 002 0952	
Shielded frame 			09 14 000 9924	



Single locking lever



Identification	Conductor cross-section (mm <sup>2</sup> )	Part number	Drawing (dimensions in mm)
Han-Modular® Twin , Bulkhead mounted housings, Han-Easy Lock®	0,5 ... 10 PE	09 14 002 0301	
Han-Modular® Twin , Panel feed through housing, Zinc die-cast		09 14 000 9928	
Han-Modular® Twin , Protection cover for bulkhead mounted housings, Metal, Closed		09 14 002 5401	

Modular

## Features

- Suitable for all Han-Modular® single modules
- The variant with PE connection uses pin 1 of the module as PE
- Slim, space saving construction type
- Low cost plastic hoods and housings





## Technical characteristics

Limiting temperature	-40 ... +85 °C
Flammability acc. to UL 94	V-0
Mating cycles	≥500
Degree of protection acc. to IEC 60529	IP65, IP20
Material (hood/housing)	Polycarbonate
Colour (hood/housing)	RAL 7032 (pebble grey)
Material (seal)	NBR
Material (accessories)	Thermoplastic

## Specifications and approvals

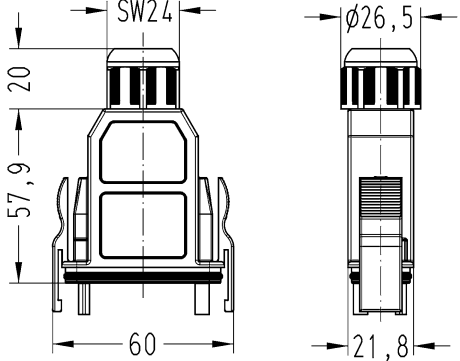

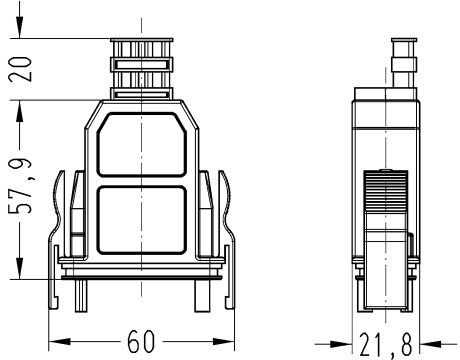

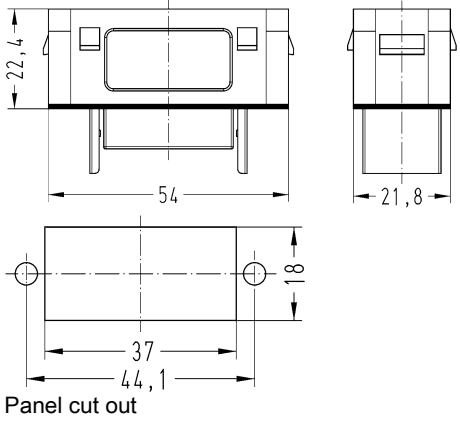
EN 60664-1  
IEC 61984

Snap-in latches

Identification	Cable entry	Cable diameter (mm)	Part number	Drawing (dimensions in mm)	
<p>Han-Modular® ECO , Hoods, Top entry, IP65</p> 	<p>1x Integrated</p>	<p>6 ... 13</p>	<p>09 14 001 0420</p>		
<p>Han-Modular® ECO , Hoods, Top entry, IP20</p> 		<p>14,65</p>	<p>09 14 001 0422</p>		
<p>Han-Modular® ECO , Bulkhead mounted housings</p> 			<p>09 14 001 0320</p>	 <p>Panel cut out</p>	

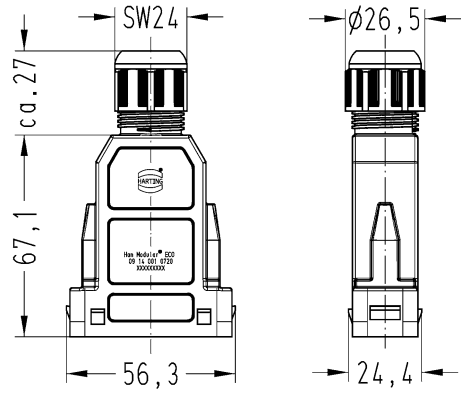
Modular

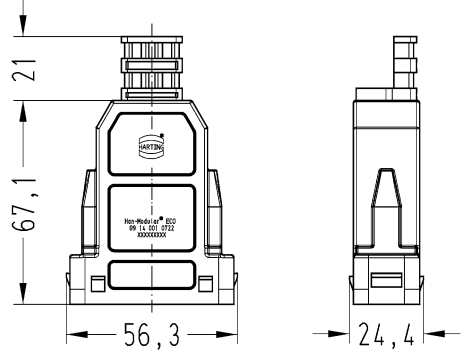
Modular





Identification	Cable entry	Cable diameter (mm)	Part number	Drawing (dimensions in mm)
<p>Han-Modular® ECO , Cable to cable housing, Top entry, IP65</p> 	<p>1x Integrated</p>	<p>6 ... 13</p>	<p>09 14 001 0720</p>	
<p>Han-Modular® ECO , Cable to cable housing, Top entry, IP20</p> 		<p>14,65</p>	<p>09 14 001 0722</p>	
<p>Han-Modular® , Coding element, Pack contents: 8 pieces per frame</p> 			<p>09 14 000 9929</p>	

Snap-in latches

Identification	Cable entry	Cable diameter (mm)	Part number	Drawing (dimensions in mm)
Han-Modular® ECO , Hoods, With PE identification (pin 1 = PE), Top entry, IP65	1x Integrated	6 ... 13	09 14 001 0421	
Han-Modular® ECO , Hoods, With PE identification (pin 1 = PE), Top entry, IP20		14,65	09 14 001 0423	
Han-Modular® ECO , Bulkhead mounted housings, With PE identification (pin 1 = PE)			09 14 001 0321	<p>Panel cut out</p>

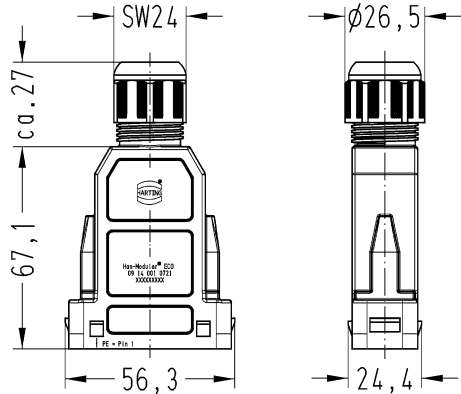
Modular

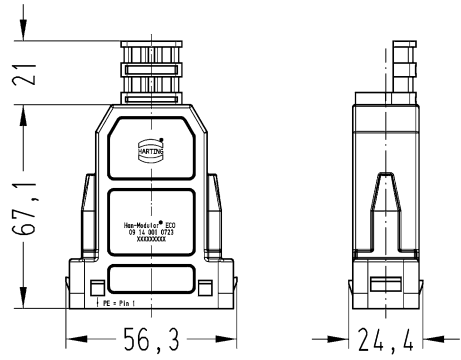
Modular





Identification	Cable entry	Cable diameter (mm)	Part number	Drawing (dimensions in mm)
<p>Han-Modular® ECO , Cable to cable housing, With PE identification (pin 1 = PE), Top entry, IP65</p> 	<p>1x Integrated</p>	<p>6 ... 13</p>	<p>09 14 001 0721</p>	
<p>Han-Modular® ECO , Cable to cable housing, With PE identification (pin 1 = PE), Top entry, IP20</p> 		<p>14,65</p>	<p>09 14 001 0723</p>	
<p>Han-Modular® , Coding element, Pack contents: 8 pieces per frame</p> 			<p>09 14 000 9929</p>	

## Technical characteristics

Limiting temperature	-40 ... +125 °C
Flammability acc. to UL 94	V-0
Mating cycles	≥500

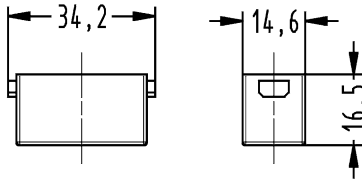
## Technical characteristics

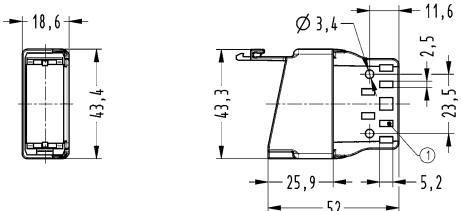

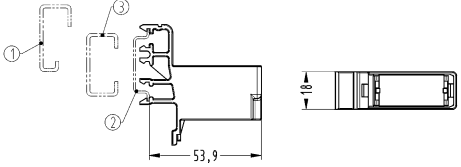
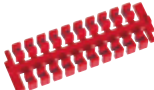
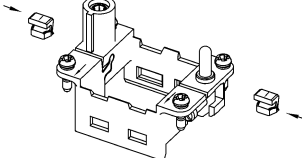

Material (insert)	Polycarbonate
Colour (insert)	RAL 7032 (pebble grey)
Material (locking)	Polycarbonate
Material (accessories)	Thermoplastic

Identification	Part number	Drawing (dimensions in mm)
Han-Modular®, Han® Dummy module  	09 14 000 9950	
Han-Modular®, Module locking system, With strain relief, Pack contents: 1 module locking system  	09 14 000 0312	 <p>① For cable ties with max. 5 mm width</p>
Han-Modular®, Module locking system, for rail, Pack contents: 1 module locking system  	09 14 000 0313	 <p>① G-rail IEC 60715-G32 ② Rail IEC 60715-35 x 7.5 with 1 mm thickness or -35 x 15 with 1.5 mm thickness ③ C-rail IEC 60715-C30</p>
Han-Modular®, Fixing, for Han-Modular® hinged frames, Pack contents: 20 pieces per frame  	09 14 000 9960	 <p>to fix the pre-assembled hinged frames</p>

## Technical characteristics

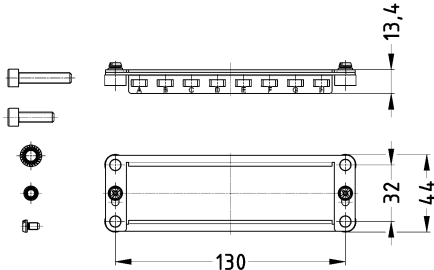
Material (accessories)      Stainless steel

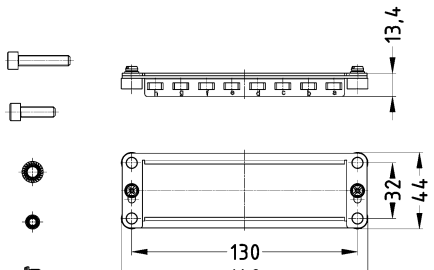
Modular

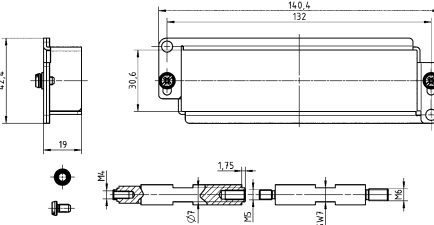
Identification	Part number	Drawing (dimensions in mm)
<p>Han-Modular®, Frame, for up to 8 single modules, Marking A ... H, Pack contents: 2 x M4 screw, 2 x washer SK S4, 4 x cheese-head screw M6 x 20, 4 x cheese-head screw M6 x 25, 4 x washer SK S6</p> 	<p>09 11 000 9935</p>	 <p>Tightening torque Fixing screws M6: 10 Nm Tightening torque Screws M4: 1.5 Nm</p>
<p>Han-Modular®, Frame, for up to 8 single modules, Marking a ... h, Pack contents: 2 x M4 screw, 2 x washer SK S4, 4 x cheese-head screw M6 x 20, 4 x cheese-head screw M6 x 25, 4 x washer SK S6</p> 	<p>09 11 000 9936</p>	 <p>Tightening torque Fixing screws M6: 10 Nm Tightening torque Screws M4: 1.5 Nm</p>
<p>Han-Modular®, Frame, for up to 8 single modules, Marking A ... H, Pack contents: 2 x M4/M5 distance bolts (A/F 7), 2 x M5/M6 distance bolts (A/F 7), 4 x M4 screw, 4 x washer SK S4</p> 	<p>09 40 024 9931</p>	 <p>Tightening torque Distance bolt 6 Nm Tightening torque Fixing screws M4: 1.5 Nm Tightening torque M4: 1.5 Nm</p>

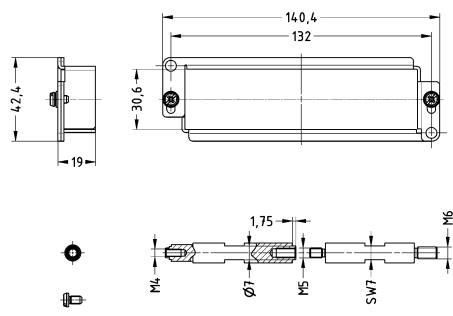

Identification	Part number	Drawing (dimensions in mm)
<p>Han-Modular®, Frame, for up to 8 single modules, Marking a ... h, Pack contents: 2 x M4/M5 distance bolts (A/F 7), 2 x M5/M6 distance bolts (A/F 7), 4 x M4 screw, 4 x washer SK S4</p> 	<p>09 40 024 9932</p>	 <p>Tightening torque Distance bolt 6 Nm Tightening torque Fixing screws M4: 1.5 Nm Tightening torque M4: 1.5 Nm</p>

Modu-  
lar

## Technical characteristics

Material (accessories)      Zinc die-cast

Modu-  
lar

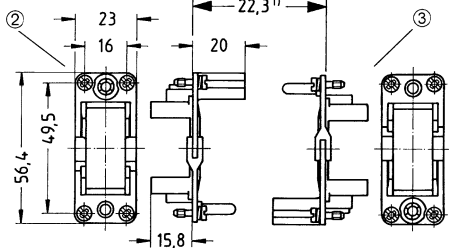
Identification	Conductor cross-section (mm <sup>2</sup> )	Part number	Drawing (dimensions in mm)
<p>Han-Modular<sup>®</sup>, Frame, for 1 module, In housing Han<sup>®</sup> 10 A</p> 	<p>0,75 ... 2,5 PE</p>	<p>09 14 000 0304</p>	 <p>① Distance max. 23.5 mm ② Hood ③ Housing</p>

## Technical characteristics

Material (contacts)      Copper alloy

Modu-  
lar

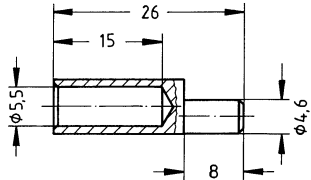
Identification	Conductor cross-section (mm <sup>2</sup> )	Part number	Drawing (dimensions in mm)
<p>Han-Modular<sup>®</sup>, Cable shoe, for PE extension</p>  <p>for hoods/housings high construction only</p>	<p>16</p>	<p>09 14 000 9912</p>	 <p>Please use pressing tools for non-insulated cable shoes</p>