



LX3V-4LTC

User manual



Website: <http://www.we-con.com.cn/en>

Technical Support: support@we-con.com.cn

Skype: fcwkkj

Phone: 86-591-87868869

QQ: 1043098682

Technical forum: <http://wecon.freeforums.net/>



1. Introduction

LX3V-4LTC is temperature control module, it has four temperature input ports and four transistor output ports (the collector is open), it reads data from thermocouple, and then output value with PID control.

LX3V-4LTC needs to connect with LX3V series PLC

- 1) Four input ports could support type K, type J, type T, type E, type N, type B, type R and type S thermocouple.
- 2) When it connects with LX3V PLC, PLC could read/write data by "FROM/TO" instruction. (LX3V-4LTC could execute PID control and output control, it does not need user to write PID ladder.)
- 3) Proportion coefficient, integral time, differential time of LX3V-4LTC can be self-tuning/
- 4) Each channel is isolation each other.

2. Dimensions

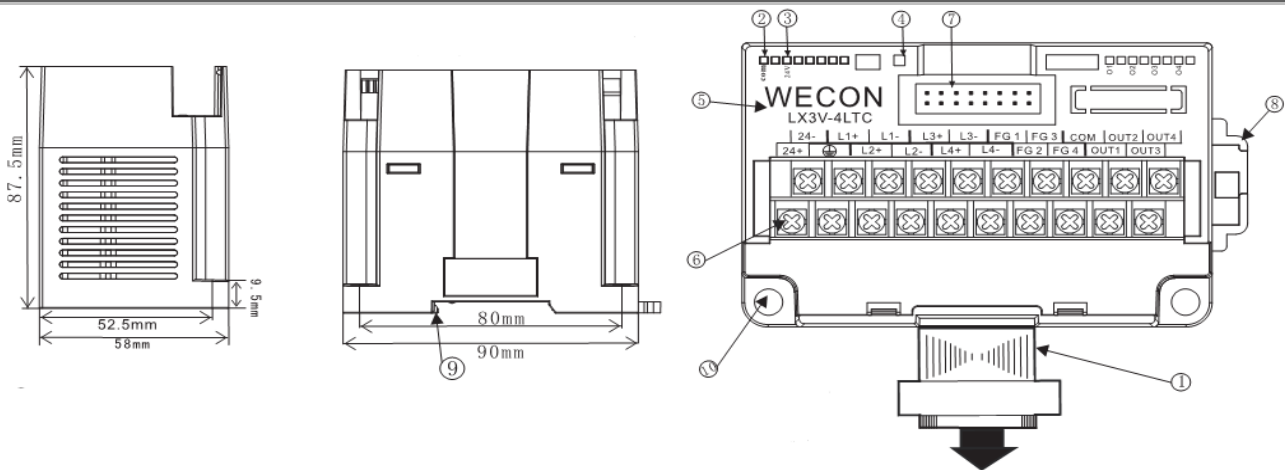

- | | |
|--|---------------------------------|
| ① Extension cable and connector | ⑥ Analog signal terminal |
| ② Com LED: Light when communicating | ⑦ Extension module interface |
| ③ Power LED: Light when connect to 24V | ⑧ DIN rail mounting slot |
| ④ State LED: Light when normal condition | ⑨ DIN rail hook |
| ⑤ Module name | ⑩ Mounting holes ($\phi 4.5$) |

Using crimp terminations

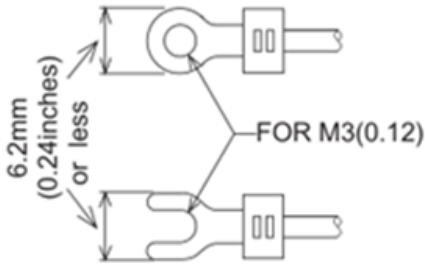

- Be sure to use the crimp-style terminals that satisfy the dimensional requirements shows in the left figure.
- Apply 0.5 to 0.8 N.m (5 to 8 kgf.cm) torque to tighten the terminals to prevent abnormal operation.
- Other terminals should be empty but only wiring terminals mention in this manual.

3. Wiring

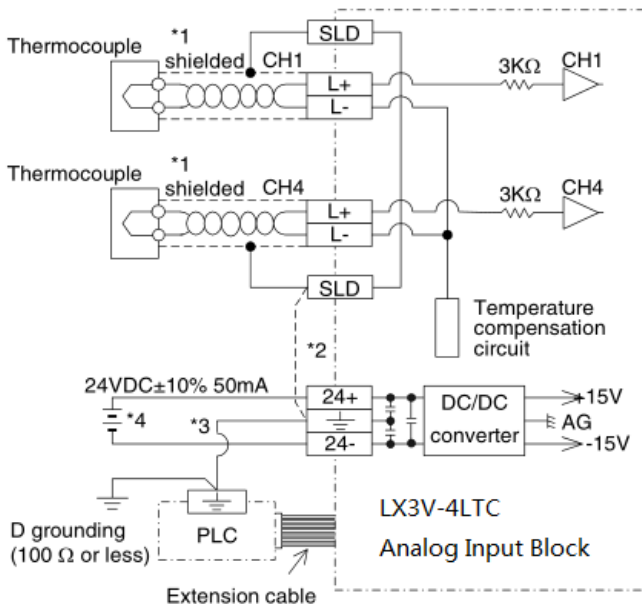

*1 The compensating cables that connect with thermocouples could be as follows:

Type K: KX-G, KX-GS, KX-H, KX-HS, WX-G, WX-H, VX-G

Type J: JX-G, JX-H

Type K: SC-G, SC-H

Type N: NC-G, NC-H

Type E: EX-G, EX-H

Type T: TX-G, TX-H

Type B: BC-G, BC-H

Type R: RC-G, RC-H

For every 10Ω of line resistance, the compensating cable will indicate a temperature 0.12°C higher than actual. Please check the line resistance before installation. Long compensating cables are more prone to noise interference, shorter (less than 100m) compensating cable is recommended.

- *2 Connect the ground terminals of the LX3V-4LTC unit with the main unit. And the main unit should be 3 grade grounding.
- *3 The built-in 24V DC output of PLC main unit could be used as the power supply of LX3V-4LTC.

Cautions

- Make sure all power be shut down before installation or wiring. Otherwise, it maybe cause electrical shock or components damaged.
- It would be dangerous if system and loads outside starts simultaneously, please make sure both

of them are interlocked each other by PLC ladder or other ways.

- Please connect the PLC main unit and LX3V-4LTC with power supply properly; the main unit or LX3V-4LTC would be damaged if AC supply connects with DC I/O or DC power terminal.
- Do not connect the empty terminals with outside wire, which could damage your devices.

4. Specifications

4.1 General specification

Item	Specification
General specifications	Same as those for the main unit
Dielectric withstand voltage	500V AC, 1min (between all terminals and ground)

4.2 Power supply specification

Item	Specification
Analog circuits	24V DC \pm 10%, 50mA
Digital circuits	5V DC, 30mA (internal power supply from the main unit)

4.3 Performance specification

Item	Centigrade (°C)		Fahrenheit (°F)	
	Both °C and °F are available by reading the appropriate buffer memory (BFM).			
Input signal	Thermocouple: Type K, J, T, E, N, B, R, S (each type can be used for each channel), 4 channels most.			
Rated temperature range	Type K	-100 to +1,200	Type K	-148 to +2,192
	Type J	-100 to +600	Type J	-148 to +1,112
	Type T	-100 to +400	Type T	-148 to +752
	Type E	-100 to +1,000	Type E	-148 to +1,832
	Type N	-100 to +1,300	Type N	-148 to +2,372
	Type B	+250 to +1,800	Type B	-482 to +3,272 °F
	Type R	-50 to +1,768	Type R	-58 to +3,214.4
	Type S	-50 to +1,768	Type S	-58 to +3,214.4
Digital output	12-bit conversion, saved in 16-bit binary complement form			
	Type K	-1,000 to +12,000	Type K	-1480 to +21,920
	Type J	-1,000 to +6,000	Type J	-1480 to +11,120

	Type T	-1,000 to +4,000	Type T	-1480 to +7,520
	Type E	-1,000 to +10,000	Type E	-1480 to +18,320
	Type N	-1,000 to +13,000	Type N	-1480 to +23,720
	Type B	+2,500 to +18,000	Type B	-4820 to +32,720
	Type R	-500 to +17,680	Type R	-580 to +32,144
	Type S	-500 to +17,680	Type S	-580 to +32,144
Resolution	Type K	0.4°C	Type K	0.72°F
	Type J	0.3°C	Type J	0.54°F
	Type T	0.4°C	Type T	0.72°F
	Type E	0.25°C	Type E	0.45°F
	Type N	0.52°C	Type N	0.936°F
	Type B	2.09°C 2.97°C (less than 1,000°C) 1.64°C (more than 1,000°C)	Type B	3.762°F 5.346°F (less than 1,832°F) 2.952°F (more than 1,832°F)
	Type R	1.53°C 1.87°C (less than 800°C) 1.32°C (more than 800°C)	Type R	2.754°F 3.366°F (less than 1,472°F) 2.376°F (more than 1,472°F)
Type S	1.72°C 2.01°C (less than 800°C) 1.53°C (more than 800°C)	Type S	3.096°F 3.618°F (less than 1,472°F) 2.754°F (more than 1,472°F)	
Overall accuracy	± (0.5% full scale +1°C)			
Calibration point	Freezing point of pure water 0°C / 32°F			

Note: Earth-tipped thermocouples are not suitable for this unit.

Analog Input

Conversion Characteristics

Readings given at calibration reference point 0°C/32°F (0/320) respectively. (subject to the overall accuracy)

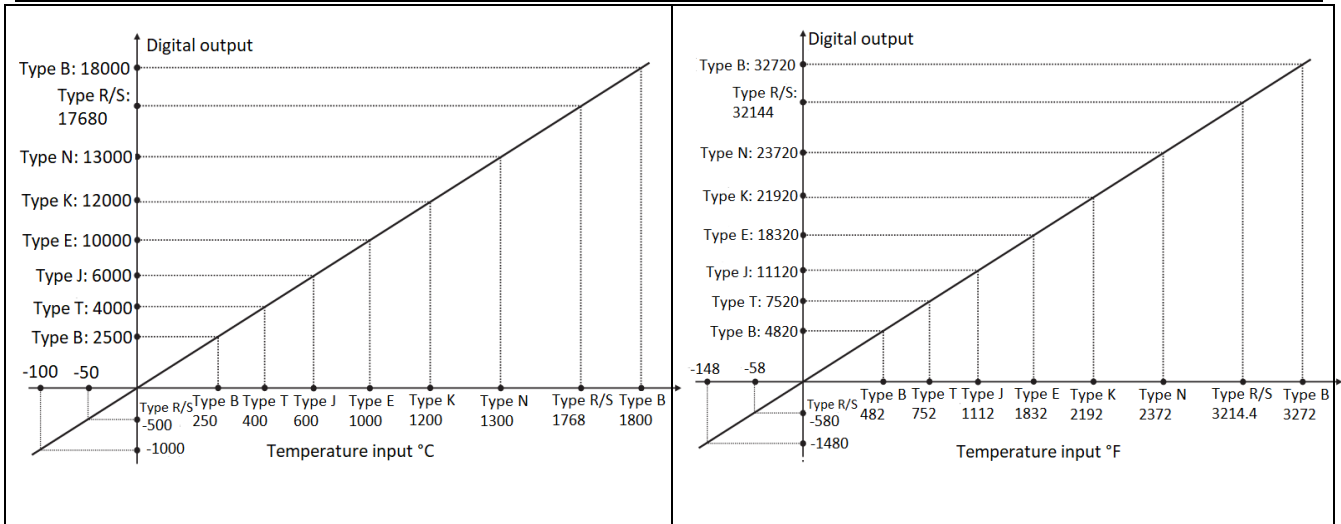

Miscellaneous

Item	Specification
Isolation	It has optical isolation between analog and digital circuits. DC/DC converter is applied to isolate between this device and MPU. It has signal isolation between each analog channel.

5. Buffer Memory (BFM)

5.1 Buffer memory list

BFM No.				Name	Latched	Operation	Default value	Contents
CH1	CH2	CH3	CH4					
#0				Thermocouple types	0	W/R	H0000	Each number of 4 HEX corresponds to one channel, the highest bit is CH4, the lowest is CH1. 0: Type K 1: Type J 2: Type T 3: Type E 4: Type N 5: Type B 6: Type R 7: Type S Others: not used.
#1	#2	#3	#4	Averaged constant of filter	0	W/R	8	Count of temperature sampling for averaging. Please set 1 for High-speed sampling. Only the range 1 to 256 is valid for the number of temperature readings to be averaged. If a

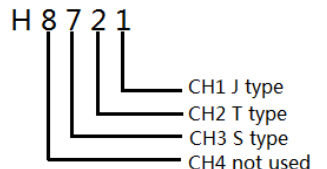

								value outside of this range is entered, a default value of 8 is used.
#5	#6	#7	#8	Averaged temp. °C	X	R	0	CH1 to CH4 Averaged temperature (unit is 0.1°C)
#9	#10	#11	#12	Present temp. °C	X	R	0	CH1 to CH4 Current temperature (unit is 0.1°C)
#13	#14	#15	#16	Averaged temp. °F	X	R	0	CH1 to CH4 Averaged temperature (unit is 0.1°C)
#17	#18	#19	#20	Present temp. °F	X	R	0	CH1 to CH4 Current temperature in (unit is 0.1°C)
#21~#27				Reserved	X	R	-	-
*#28				Error latch	X	W/R	0	Digital range error latch
#29				Error status	X	R	-	B0: A/D conversion would be stopped when b2 or b3 is ON. B1: Not used; B2: power failed; B3: Hardware failed; B4~B7: Not used; B8: Values backup error; B10: Digital output/analog input value is out of the specified range; B11: Averaged value is out of the available range; B13: backup error(during executing value backup(BFM42 is non-zero),and backup failed, this bit is ON.) B14: It is in backup status(during executing value backup(BFM42 is non-zero),and backup failed, this bit is ON.) B15: Initialization completion flag;(during initializing, (BFM42 is 1 or 2), when it finished, this bit is ON.)
#30				Identification	-	R	-	Identification code: K2130
#31				Software version	-	R	-	Software version
#32~#40				Reserved	-	-	-	Reserved
#41				Initialization command	X	W/R	0	0: Performs nothing 1: Initializes all data 2: Initializes BFM #19 to BFM #174 3: Initializes error Others: No action
#42				Backing up data to EEPROM	X	W/R	0	0: Performs nothing Other: Performs backups

#43	#81	#119	#157	Error flag (Temperature control is stopped)	X	R	0	b0: Reserved; b1: value range setting error; b2: PID self-tuning error; b3: The difference of setting value and offset value of PID self-tuning is too small; b4~b5: Reserved; b6: Channel mode Error/ This channel is not enabled; b7: PV exceeded; b8: PID self-tuning parameters are changed in process;
#44	#82	#120	#158	Event (PID continue)	X	-	0	b0 & b15: Reserved; b4: Alarm 1 - When alarm 1 occurs, it is set ON; b5: Alarm 2 - When alarm 2 occurs, it is set ON; b6: Alarm 3 - When alarm 3 occurs, it is set ON; b7: Alarm 4 - When alarm 4 occurs, it is set ON; b8: Heating control; b9: Cooling control; b10: PID terminals output; b11: PID control flag; b12: Manual flag; b13: Self-tuning; b14: ON / OFF control;
#45	#83	#121	#159	Current target temp. (PV)	X	R	0	Unit: 0.1 °C Sampling temperature (from averaged value) during executing.
#46	#84	#122	#160	Control output value (MV)	X	R		The output value of PID calculation, This value is equal with output value (BFM49) during manual control.
#47	#85	#123	#161	Control start/stop changeover	X	W/R	0	0: Stops control; Other: Starts control;
#48	#86	#124	#162	Auto/manual mode changeover	0	W/R	0	0: AUTO; Other: MAN;
#49	#87	#125	#163	Manual output set value	0	W/R	0	The value is equal to the value of control output in manual mode.
#50	#88	#12	#16	Self-tuning	0	W/R	0	0: Stops self-tuning;

		6	4	g execution comman d				Other : starts self-tuning;
#51	#89	#12 7	#16 5	Heating / cooling control	0	W/R	0	0: Heating control; 1: Cooling control;
#52	#90	#12 8	#16 6	Setting value (SV)	0	W/R	0	Unit: 0.1 °C The target temperature of PID control
#53	#91	#12 9	#16 7	KP (Scaling coefficien t)	0	W/R	3	KP = 0, ON / OFF control is executed. Range: 0-32767. Note: This value is magnified 256 times; the actual value is KP / 256.
#54	#92	#13 0	#16 8	TI (Integral coefficien t)	0	W/R	2400	0-32767
#55	#93	#13 1	#16 9	TD (Different ial coefficien t)	0	W/R	600	0-32767
#56	#94	#13 2	#17 0	TS (Sampling cycle)	0	W/R	5	1-100 (*500ms)
#57	#95	#13 3	#17 1	Filter coefficien ts	0	W/R	0	0-1023
#58	#96	#13 4	#17 2	DetaT	0	W/R	100	The maximum rate of rise: 0-320; Range: 0-32000 (0-320);
#59	#97	#13 5	#17 3	Control cycle	0	W/R	20	1-100 (*500ms); Range: 0.5s-50s;
#60	#98	#13 6	#17 4	Self-tunin g bias	0	W/R	0	± Input range (Unit: 0.1 °C)
#61	#99	#13 7	#17 5	Reserved	-	-	-	Reserved
#62	#10 0	#13 8	#17 6	Dead zone setting	0	W/R	0	Dead zone is used for ON/OFF control mode Range: 0-100 (Unit: 0.1%)
#63	#10 1	#13 9	#17 7	PV upper limit	0	W/R	12000	Lower & upper threshold of input (Unit: 0.1 °C) Remark: This BFM is used for the upper threshold of input value.

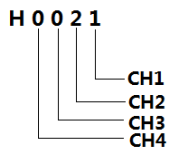
								Range: K type: -100°C - 1200°C J type: -100°C - 600°C
#64	#10 2	#14 0	#17 8	PV lower limit	0	W/R	-1000	Lower & upper threshold of input (Unit: 0.1 °C) Remark: This BFM is used for setting lower threshold of input. Range: K type: -100°C - 1200°C J type: -100°C - 600°C
#65	#10 3	#14 1	#17 9	MV upper limit	0	W/R	100	This BFM is used for setting the upper threshold of output. Range: 0-2000
#66	#10 4	#14 2	#18 0	MV lower limit	0	W/R	0	This BFM is used for setting the lower threshold of output. Range: 0-2000
#67	#10 5	#14 3	#18 1	Reserved	-	-	-	Reserved
#68	#10 6	#14 4	#18 2	Alarm mode setting	0	W/R	0	It is used for alarm mode of four channels; [Example]  0: Disable alarm 1: Alarm upper limit 2: Alarm lower limit
#69	#10 7	#14 5	#18 3	Alarm 1 set value	0	W/R	0	Unit: °C The alarm range, it depends on alarm mode.
#70	#10 8	#14 6	#18 4	Alarm 2 set value	0	W/R	0	
#71	#10 9	#14 7	#18 5	Alarm 3 set value	0	W/R	0	
#72	#11 0	#14 8	#18 6	Alarm 4 set value	0	W/R	0	
#73	#11 1	#14 9	#18 7	Alarm dead zone setting	0	W/R	0	Calculation of dead zone Bias: (SV+ bias)* dead zone Upper & lower threshold mode: Alarm setting value* dead zone
#74	#11 2	#15 0	#18 8	Alarm delay times	0	W/R	0	Range: 0-255
#75	#11 3	#15 1	#18 9	Setting the wrong address	0	R	0	0: Normal; Others: Error in setting address
#76	#11	#15	#19	Reserved	-	-	-	Reserved

~#8	4~#	2~#	0~#					
0	118	156	193					

Note:

- O: Retentive;
- X: Non-retentive;
- R: Only read is enabled;
- R/W: Both read and write are enabled;

5.2 Details of buffer memories

1) Buffer Memory BFM #0: Thermocouple Type K or J selection mode

BFM #0 is used for selecting type K or J thermocouples for each channel. Each bit of a 4 digit hexadecimal number corresponds to one channel, the last digit is channel 1.

[Example]

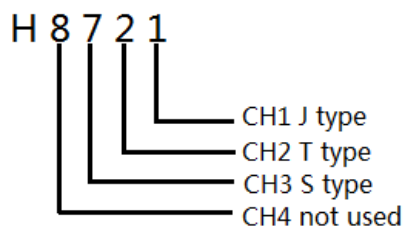

The time of A/D conversion is 240ms for each channel. When "3" (unused) is set for a channel, this channel would not have A/D conversion, therefore, the total time for conversion decreases.

In the above example, the conversion time is as follows:

240ms (conversion time per channel) × 2channels (number of channels used) = 480ms (total conversion time)

2) Buffer Memory BFMs #1 to #4: Number of temperature readings to be averaged

When the value of averaged temperature is assigned to BFMs #1 to #4, the averaged data is stored in BFMs #5 to #8 (°C) and #13 to #16 (°F). Only the range 1 to 256 is valid for the number of averaged temperature. If a value out of this range, the default value is 8.

3) Buffer Memory BFMs #9 to #12 and #17 to #20: Current temperature

These BFMs store the current input value. This value is stored in units of 0.1°C or 0.1°F, but the resolution is only 0.4°C or 0.72°F for Type K and 0.3°C or 0.54°F for Type J.

4) Buffer Memory BFM #28: Digital range error latch

BFM #29 b10(digital range error) is used for confirm if the measured temperature is in the

range of this unit.

BFM #28 latches the error status of each channel and can be used to check for thermocouple disconnection.

b15 ~ b8	b7	b6	b5	b4	b3	b2	b1	b0
Not used	High	Low	High	Low	High	Low	High	Low
	CH4		CH3		CH2		CH1	

Low: Latches ON when the measured temperature drops down and less than the lowest temperature threshold.

High: Turns ON when measured temperature rises up and more than the highest temperature threshold, or the thermocouple was disconnected.

When an error occur the temperature data before the error is latched. If the measured value returns to normal threshold, all data return to run properly again. (Note: The error remains latched in (BFM #28))

An error can be cleared by writing K0 to BFM #28 using the TO instruction or turning off the power.

5) Buffer Memory BFM #29: Error status

Bit devices of BFM #29	Error information
b0	Error, when either b1~ b3 is ON, A/D conversion is stopped.
b1, b4~b7	Not used;
b2	24V DC power supply failed;
b3	Hardware failed;
b8	Backup error of set value.
b10	Digital output/analog input value is out of the specified range;
b11	The value of averaged results is out of the available range;
b13	Backup error, during executing of backup,(BFM42 is non-zero) , and backup failed, this bit sets to ON;
b14	It is in backup status, this bit sets to ON;
b15	Initialization completion flag;

6) ID Code Buffer Memory BFM #30

The identification code or ID number for this Special Block is read from buffer memory BFM #30 by FROM instruction. This number for the LX3V-4LTC unit is K2130. The PLC can use this ID in program to identify the special block before commencing data transfer to and from the special block.

7) Error flag BFM #43, BFM#81, BFM#119, BFM#157 (Temperature control is stopped)

Error flag	Content	Remark
b0, b4, b5	Not used;	-
b1	Error in setting value range.	When set value is out of the specified range, this bit sets to ON. The error addresses will be showed in BFM#75, BFM#113, BFM#151, BFM#189
b2	PID self-tuning error;	When either b3 or b8 is ON, this bit set ON
b3	The difference of set value and offset are too small.	The difference between measured temperature (PV) and SV + DIFF less than 100 in self-tuning mode, or SV+DIFF exceeded PV's range. This bit sets to ON
b6	Channel mode Error/ This channel is disable;	When the channel is disabled by BFM#0, this bit sets to ON.
b7	PV exceeded;	When measured temperature exceeded PV's range, this bit sets to ON.
b8	PID self-tuning parameters are changed in process;	When one of upper & lower threshold, set value, bias changes, this bit sets to ON.

8) BFM #48 (CH1), BFM #86 (CH2), BFM#124(CH3), BFM#162(CH4) : Auto/manual mode changeover

BFM #48 is used for changing the mode of CH1. BFM #86 is used for changing the mode of CH2. BFM #124 is used for changing the mode of CH3. BFM #162 is used for the mode of CH4. When BFM #48/#86/#124/#162 is set to "K0 (initialized value)", the auto mode is selected. When BFM #48/#86/#124/#162 is set to "K1", the manual mode is selected.

Auto mode:

The measured value (PV) is compared with the set value (SV), PID arithmetic operation is performed, then output the control value (MV).

In the auto mode, the manual output set value (CH1: BFM #48, CH2: BFM #86, CH3: BFM#124, CH4:BFM#162) is always equal with the control output value.

Manual mode:

The control output (MV) value is fixed to the manual output set value (CH1: BFM #48, CH2: BFM #86, CH3: BFM#124, CH4:BFM#162).

The manual output set value can be changed while b13 of the event (CH1: BFM #48, CH2: BFM #86, CH3: BFM#124, CH4:BFM#162) is ON even if operation is performed in the manual mode.

The temperature alarm function is effective even in the manual mode.

9) Self-tuning function

Self-tuning

The self-tuning function automatically measures, calculates and sets the most optimal PID constants in accordance with the set temperature.

When the self-tuning execution command (CH1: BFM #48, CH2: BFM #86, CH3: BFM#124, CH4: BFM#162) is set to "1", self-tuning is performed. (Self-tuning can start from an arbitrary status at any time immediately after the power is turned ON, while the temperature is rising or while control is stable.)

When self-tuning starts, two-position control is performed using the set value (SV). By two-position control, the output is forcedly hunted and its amplitude and oscillation cycle are measured. PID constants are calculated based on the measured values, and stored in each parameter. When self-tuning normally finishes, control continues with new calculated PID constants.

While self-tuning is performed, b14 of the event (CH1: BFM #48, CH2: BFM #86, CH3: BFM#124, CH4: BFM#162) is set to "1".

(In order to calculate proper PID constants by self-tuning, set the upper limit of the output limiter to 2000, the lower limit of the output limiter to 0.)

a) Self-tuning can be started with the following conditions:

- The control start/stop changeover set to "1: Starts control".
- The operation mode sets to "2: Monitor + Temperature alarm + Control".
- The auto/manual mode is "0: AUTO".
- The measured value PV is normal.
- The upper threshold and lower threshold for output should be different.

b) Self-tuning would be canceled with one of the following conditions:

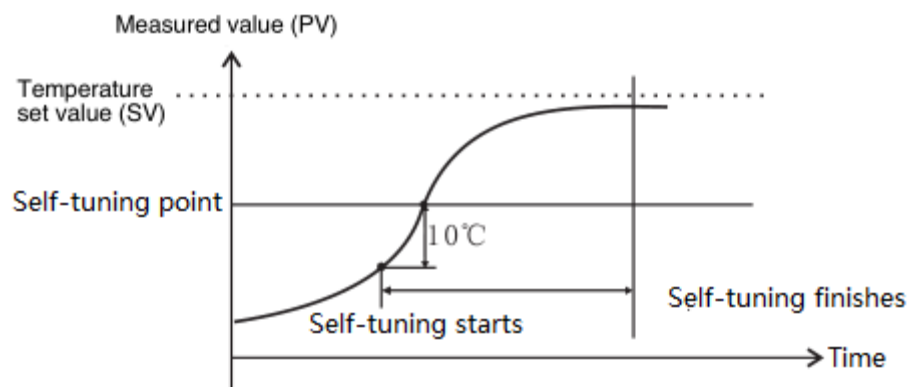

- SV value has been changed.
- The control has been stopped, the operation mode is "0: Stops control".
- The auto/manual mode is set to "1: MAN".
- The PV bias has been changed.

- The upper and lower threshold for output has been changed.
- The self-tuning executed command is set to "0: Stops auto tuning".
- Power failed

Self-tuning bias

If the self-tuning bias has been used for auto-tuning, The measured value (PV) should not exceed the set value (SV). The self-tuning makes the measured value vibrating and SV switching ON/OFF, then calculates and sets each PID constant. However, for some control targets, overshoot by vibration is not permitted, Set the self-tuning bias is necessary for this case. The set value(SV) could be changed when self-tuning bias is set.

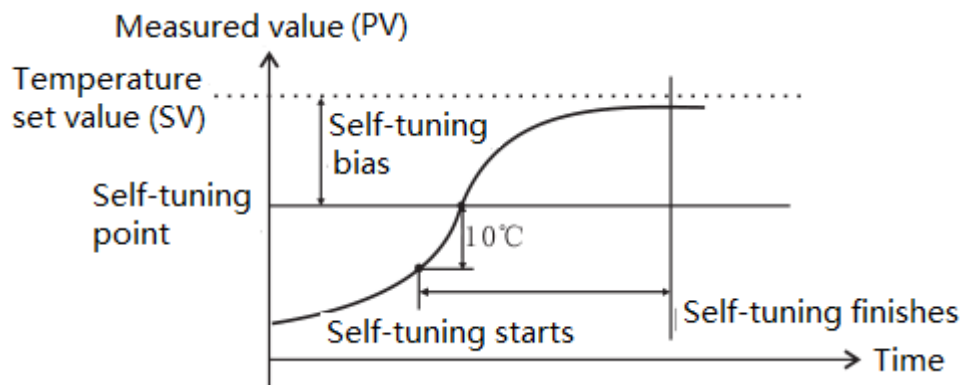

10) Dead zone (adjustment sensitivity) setting

BFM #62 is used for dead zone of CH1. BFM #100 is used for the dead zone of CH2. BFM #138 is used for the dead zone of CH3. BFM #176 is used for the dead zone of CH4.

When system has been turning ON/OFF operations, if the adjustment sensitivity has been configured, it could avoid temperature value (SV) show ON/OFF changes nearby.

The value set to BFM #62/#100/#138/#176 is equally to the value of the upper and the lower area of the temperature set value (BFM #52/#90/#128/#166).

For example, if the sensitive value sets to "10%", 5% above and 5% below of the set value would be treated as the dead zone (width of 10% in total).

Example

a) Conditions:

When BFM #41/#60 is set to "10.0%" in the range span of 400°C

$$400^{\circ}\text{C} \times 10.0\% / 100 = 40^{\circ}\text{C}$$

When the temperature set value is 200°C, the range from 180 to 220°C is treated as the dead zone.

When the dead zone sets to a large value, vertical fluctuation would be larger. But if dead zone is too small, small oscillations of the measured value may cause vibration.

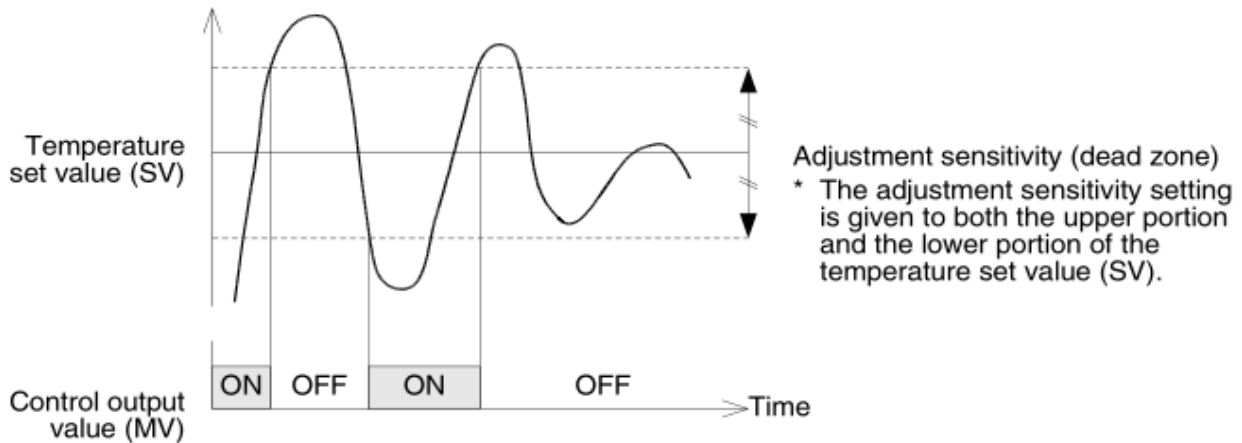

11) Output(MV) upper threshold: BFM #65/#103/#141/#179

Output(MV) lower threshold: BFM #66/#104/#142/#180

BFM #65/#103/#141/#179 are used for output upper threshold of CH1/CH2/CH3/CH4.

BFM #66/#104/#142/#180 are used for output lower threshold of CH1/CH2/CH3/CH4.

These BFM's could be used for setting the upper threshold and the lower threshold of the control output value (MV) (BFM #46/#84/#122/#160). The range of the upper threshold is from the lower threshold of the output limiter to 2000. The range of the upper threshold is from 0 to the upper threshold of the output limiter.

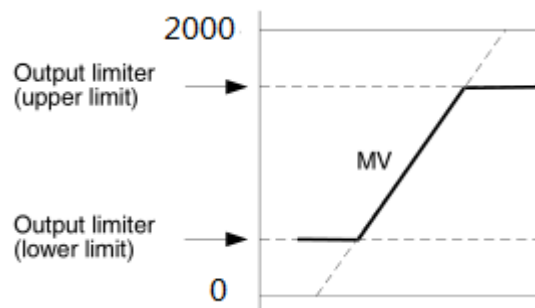

- Proper PID constants could not be obtained during self-tuning while the output limiter is active. So it is not recommended not to use the output limiter when self-tuning is active.
- The output limiter would not be active when two-position control is active.
- If lower threshold and self-tuning is active, please set the upper and lower threshold for PV, otherwise the temperature may continue to rise, and out of system control.

12) Alarm mode setting: BFM#68/ BFM#106/ BFM#144/ BFM#182

LX3V-4LTC has 12 alarm modes. Four of them most could be used meanwhile. BFM #68 is used for CH1 alarm mode, BFM#106 is used for CH2 alarm mode, BFM#144 is used for CH3 mode, BFM#182 is used for CH4 alarm mode.

Each channel could have four alarm modes.

[Example]

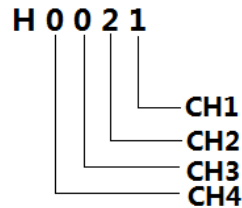

0: Disable alarm

1: Alarm upper limit

2: Alarm lower limit

Example: BFM#68=H0021 means CH1 has the following four type alarm modes: the first is upper threshold alarm, second is lower threshold, third is close alarm, and fourth is close alarm.

For detailed please refer to the following table

Alarm No.	Alarm mode	Description	Set range
0	Alarm is disabled	Alarm function is disabled.	---
1	Alarm for Upper threshold of input value	Alarms if measured value (PV) is more than value of alarm.	Input range
2	Alarm for lower threshold of input value	Alarms if measured value (PV) is less than value of alarm.	Input range
3	Alarm for upper threshold deviation	Alarms if deviation (= Measured value (PV) – Set value (SV)) is more than value of alarm.	\pm Input width
4	Alarm for lower threshold deviation	Alarms if deviation (= Measured value (PV) – Set value (SV)) is less than value of alarm.	\pm Input width
5	Alarm for Upper/lower limit deviation	Alarms if absolute deviation (= Measured value (PV) – Set value (SV)) is less than value of alarm.	+Input width
6	Range alarm	Alarms if absolute deviation (= Measured value (PV) – Set value (SV)) is less than value of alarm.	+Input width
7	Alarm for upper threshold input value alarm with wait	Alarms if measured value (PV) is more than set value, However, measured value is ignored at the start of system.	Input range
8	Alarm for lower threshold input value alarm with wait	Alarms if measured value (PV) is less than set value, However, measured value are ignored at the start of system.	Input range
9	Alarm for upper threshold deviation with wait	Alarms if deviation (= Measured value (PV) – Set value (SV)) is more than value of alarm. However, measured value is ignored at the	\pm Input width

		start of system.	
10	Alarm for lower threshold deviation with wait	Alarms if deviation (= Measured value (PV) – Set value (SV)) is less than value of alarm. However, measured value is ignored at the start of system.	±Input width
11	Alarm for Upper/lower limit deviation with wait	Alarms if absolute deviation (= Measured value (PV) – Set value (SV)) is less than value of alarm. However, measured value is ignored at the start of system.	+Input width

Note:

- Input range: it is from the lower threshold to the upper threshold of input value
- Input width: Width from the lower threshold to the upper threshold of input value (Input width = Upper threshold value - Lower threshold value).
- ±Input width: it could be positive and negative.
- + Input width: it could be positive only.

13) Alarm dead zone setting

BFM #73 is used for the dead zone of alarms 1 to 4 for CH1. BFM #111 is used for the dead zone of alarms 1 to 4 for CH2. BFM #149 is used for the dead zone of alarms 1 to 4 for CH3. BFM #187 is used for the dead zone of alarms 1 to 4 for CH4. When the measured value (PV) is near the alarm set value, the alarm status and the non-alarm status may be repeated by fluctuation in input area. In this case, setting the alarm dead zone could avoid the repeating of the alarm status and the non-alarm status.

The allowable set range is the input range (from 0.0 to 10.0 %.)

Calculation of dead zone

In deviation mode: dead zone = (SV + deviation) * dead zone

In upper/lower threshold mode: dead zone = alarm setting value * dead zone

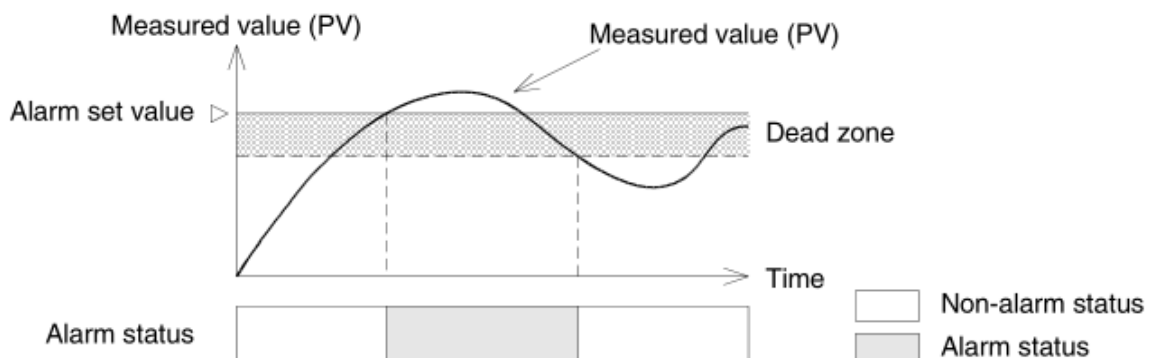
a) Upper threshold input alarm and upper threshold deviation alarm

b) Lower threshold input alarm and lower threshold deviation alarm

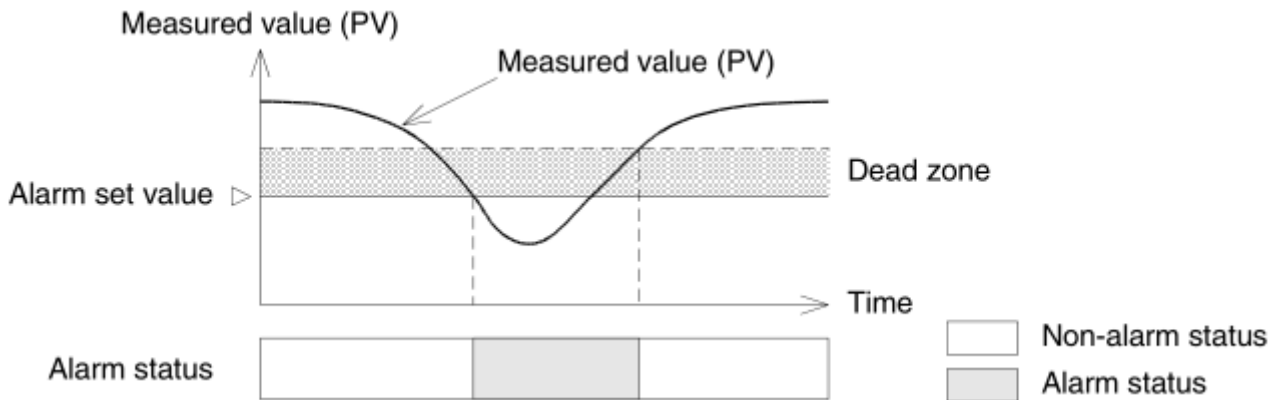

c) Upper/lower threshold deviation alarm

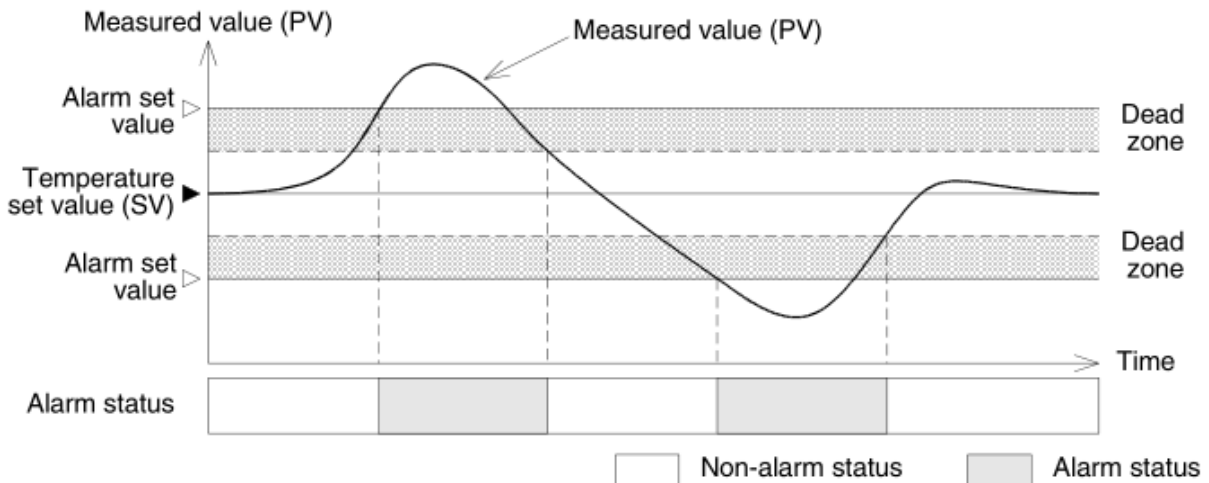

14) Number of times of alarm delay

BFM #74/#112/#150/#188 are used for the number of alarm delays of CH1/CH2/CH3/CH4 respectively. This setting is active for all alarms 1 to 4.

The alarm delay function keeps non-alarm status until the number of input samples exceeds the number of alarm delays, after the deviation between the measured value (PV) and the set value (SV) reaches the alarm set value. If the deviation is in the alarm range, the Alarm happens when the deviation remains in the alarm range until the number of input samples exceeds the number of alarm delays

Example: the number of alarm delay sets to 5 times

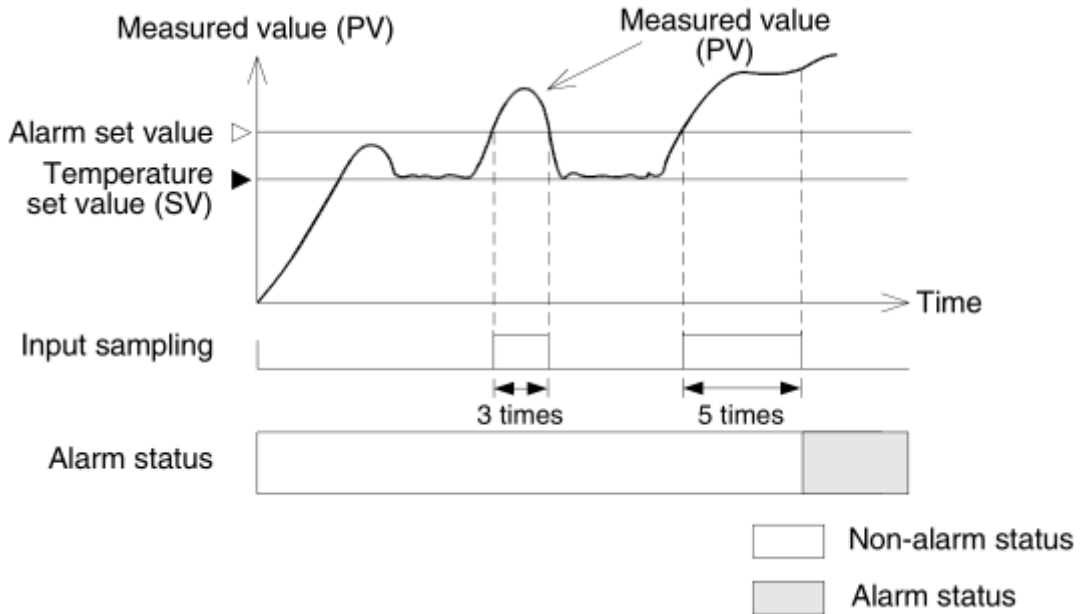

15) Address of value range error

When there has an out-of-range error occurs in the set value, BFM #75/#113/#151/#189 will show the error address,

BFM #75/#113/#151/#189 sets to "0" when no error happens.

When an error occurs, the value of BFM #75/#113/#151/#189 is the address of BFM has errors, please check the range, and give a normal value for this BFM, please clear the error after that (BFM#41).

16) Output cycle control

BFM #59 is used for the control output cycle of CH1. BFM #97 is used for the control output cycle of CH2. BFM #135 is used for control output cycle of CH3. BFM #173 is used for the control output cycle of CH4. Control cycle is longer than sampling cycle, the sampling cycle is equal with control output cycle when control cycle is less than sampling cycle.

This value multiplies by the control output value and divided by 2000 is treated as the ON time.

This value multiplies by "2000 - Control cycle value (%)/2000" is the OFF time.

The allowable range of this value is from 1 to 100 sec.

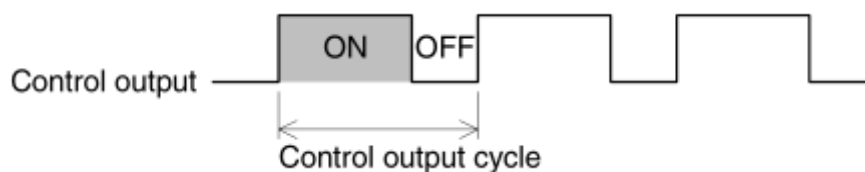

6. Program Example

- Keep doing nothing while the power is supplied.
If you touch a terminal while the power is supplied, you may get electrical shock or the unit may malfunction.
- Make sure the power be OFF before cleaning the unit or tightening the terminals.
If you clean the unit or tighten the terminals while the power is supplied, you may get electrical shock.
- To run temperature control module in safe, please read this manual carefully firstly.
Damages or accidents would happen if the operations is not right.
- Never disassemble or modify the unit. Disassembly or modification may cause failure, malfunction and fire.
* For repair, contact WECON Technology Co., Ltd.
- Make sure power is off before wiring.
Failure or malfunction maybe happen because of wiring during power is on.

6.1 Simple example

In this example, LX3V-4LTC module occupies the position of No.2 special module (This is the 3rd model connects with CPU). CH1 connects with K type thermocouple, CH2 connects with J type thermocouple, CH3 and CH4 connects with E type thermocouple, the average is 4. The value of CH1~CH4 are written to D0~D3.

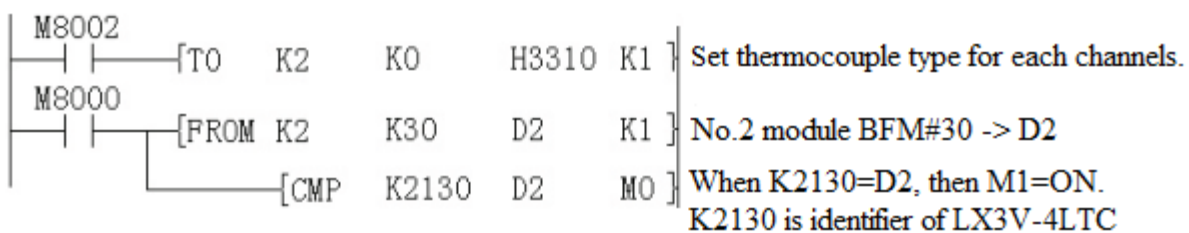

Initialization to check if the No.2 special module is LX3V-4LTC. The ID code should be as K2130 (BFM#30).

6.2 Program example

Input range: K type -- 100.0 to 400.0 °C

PID values: it is determined by auto-tuning

Alarm: Upper threshold alarm is 820 and lower threshold alarm is 780

Heater/cooling control: Heater (Initialization)

- Device assignment:
 - X000: initialization
 - X001: Reset the flag of error bit.
 - X002: Control starts (ON)/stop (OFF);
 - X003: self-tuning beginning when it changes from 0 to 1.
 - M0~M15: Flags of error
 - M20~M35: Flags of events
 - D0~D199: Read value from BFM
 - D200~D399: Write set value(SV) into BFM

● Project:

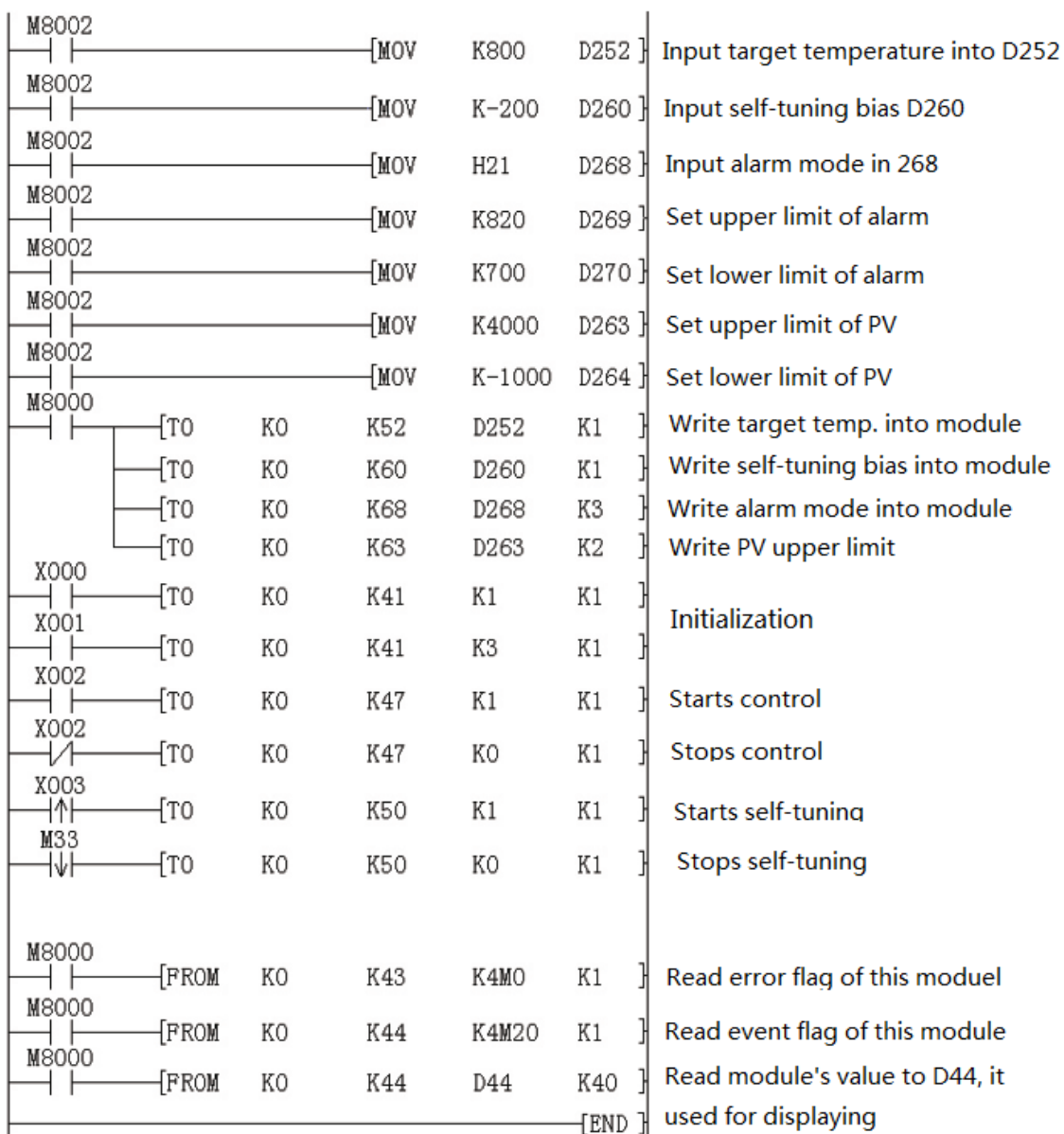

7. Diagnostic

7.1 Basic check

- Check whether the input/output wiring and/or extension cables are properly connected with LX3V-4LTC analog special function block
- All configurations should follow the rule of LX3V configuration. The number of special function blocks does not exceed 16 and the total number of PLC system should exceed 256.
- Ensure that all operating ranges is normal.
- Ensure there is no power overload in either the 5V or 24V power supplies, Warning: the load for LX3V MPU or other powered extension unit is variable with the number of modules or special modules .
- The main processing unit (MPU) is in RUN status.

7.2 Error checking

If LX3V-4LTC cannot run properly, please check the following items.

- Check the status of the POWER LED.
Lit: The extension cable is connected properly.
Otherwise: Check the connection of the extension cable.
- Check the external wiring.
- Check the status of the “24V” LED (top right corner of the LX3V-4LTC).
Lit:LX3V-4LTC is ON, 24V DC power source is ON.
Otherwise: Possible 24VDC power failure, if ON possible LX3V-4LTC failure.
- Check the status of the “A/D” LED (top right corner of the LX3V-4LTC).
Lit: A/D conversion is proceeding normally.
Otherwise :Check buffer memory #29 (error status). If any bits (b0, b2, b3) are ON, then this is why the A/D LED is OFF.