

VFD dimensions

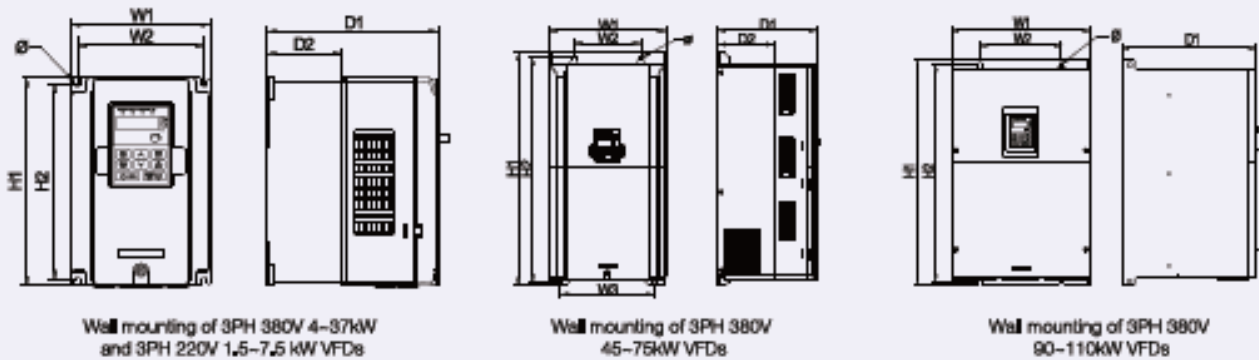

Wall mounting of 3PH 380V 4-37kW
and 3PH 220V 1.5-7.5 kW VFDs

Wall mounting of 3PH 380V
45-75kW VFDs

Wall mounting of 3PH 380V
90-110kW VFDs

Dimensions (unit: mm)

Model	W1	W2	W3	H1	H2	D1	D2	Hole (d)
GD20-1R5G-2	146,0	131,0	—	256,0	243,5	167,0	84,5	6
GD20-2R2G-2	146,0	131,0	—	256,0	243,5	167,0	84,5	6
GD20-004G-2	146,0	131,0	—	256,0	243,5	167,0	84,5	6
GD20-5R5G-2	170,0	151,0	—	320,0	303,5	196,3	113,0	6
GD20-7R5G-2	170,0	151,0	—	320,0	303,5	196,3	113,0	6
GD20-004G-4	146,0	131,0	—	256,0	243,5	167,0	84,5	6
GD20-5R5G-4	146,0	131,0	—	256,0	243,5	167,0	84,5	6
GD20-7R5G-4	170,0	151,0	—	320,0	303,5	196,3	113,0	6
GD20-011G-4	170,0	151,0	—	320,0	303,5	196,3	113,0	6
GD20-015G-4	170,0	151,0	—	320,0	303,5	196,3	113,0	6
GD20-018G-4	200,0	185,0	—	340,6	326,6	184,3	104,5	6
GD20-022G-4	200,0	185,0	—	340,6	326,6	184,3	104,5	6
GD20-030G-4	250,0	230,0	—	400,0	380,0	202,0	123,5	6
GD20-037G-4	250,0	230,0	—	400,0	380,0	202,0	123,5	6
GD20-045G-4	282,0	160,0	226,0	560,0	542,0	238,0	138,0	9
GD20-055G-4	282,0	160,0	226,0	560,0	542,0	238,0	138,0	9
GD20-075G-4	282,0	160,0	226,0	560,0	542,0	238,0	138,0	9
GD20-090G-4	338,0	200,0	—	554,0	535,0	329,2	—	9,5
GD20-110G-4	338,0	200,0	—	554,0	535,0	329,2	—	9,5

