

TECHNICAL REFERENCE

– Realtime Express (RTEX) Communication Specification –

MODEL

Product Name: AC Servo Driver

Model No.: MINAS-A6N series (RTEX communication type)

Issued on
Dec. 28, 2015

Revised on
May. 28, 2018

Motor Business Unit, Electromechanical Control Business Division
Automotive & Industrial Systems Company, Panasonic Corporation

7-1-1 Morofuku, Daito-City, Osaka 574-0044, Japan

Phone: +81-72-871-1212

Fax : +81-72-870-3151

この英文仕様書は、原本である和文仕様書を元にパナソニック株式会社モータビジネスユニットが翻訳・発行するものです。翻訳は、原本の利用に際して一応の参考となるように便宜的に仮訳したものであり、公的な校閲を受けたものではありません。英語訳のみを使用して生じた不都合な事態に関しては、当社は一切責任を負うものではありません。和文仕様書のみが有効です。

パナソニック株式会社 オートモーティブ&インダストリアルシステムズ社
メカトロニクス事業部 モータビジネスユニット

This English specification is made and published by Motor Business Unit, Panasonic Corporation based on the original Japanese specification. Translation is provided unofficially only for the sake of convenience of utilizing the original Japanese specification as a measure of reference. It is not officially reviewed. Motor Business Unit, Panasonic Corporation is not liable for any disadvantages caused by utilizing only English specification. Only the Japanese specification is effective.

Motor Business Unit, Electromechanical Control Business Division,
Automotive & Industrial Systems Company, Panasonic Corporation

Revisions

Date	Page	Rev.	Description	Signed
Dec. 28, 2015		1.0	NEWLY ISSUED	-
Feb. 12, 2016	All pages	1.1	<ul style="list-style-type: none"> • Changed the parameter names below in consideration of consistency with other models. Pr7.10、Pr7.11、Pr7.12、Pr7.15 	
	P152		<ul style="list-style-type: none"> • Addition Added the precautions about NOP (00h) switching immediately after control mode switching. 	
	P156		<ul style="list-style-type: none"> • Addition Added the precautions about the feedforward function. 	
May. 20, 2016	P1	2.0	Software upgrade CPU1 Ver1.04 -> Ver1.05 CPU2 Ver1.01 -> Ver1.02 1) Function addition "Extend the quadrant projection suppression function" (* No additions and corrections to this document) 2) Function addition "Correction function for detection delay of latch position" - Added the description of correcting of delaying latch position detection.	
	P70		<ul style="list-style-type: none"> • Addition Added The table of changes. 	
	P1		<ul style="list-style-type: none"> • Addition Added cautions of default setting 	
	P74		<ul style="list-style-type: none"> • Correction Corrected the description of Type Code 004h -> Manufacturer use 	
	P91		<ul style="list-style-type: none"> • Correction Corrected the description of Type Code 37h -> Manufacturer use 	
Sep. 9,2016	P1, P2, P3	3.0	Software upgrade CPU1 Ver1.05 -> Ver1.20 CPU2 Ver1.02 -> Ver1.20 Added the functional comparison chart of A6N series.	
	P106		1) Function addition "Deterioration diagnosis warning function"	
	(No change in this document)		2) Function addition "Slow stop function"	
	(No change in this document)		3) Function addition "Dynamic brake (DB) operation function by I/O."	
	(No change in this document)		4) Function addition "Battery refresh function"	
	(No change in this document)		5) Function addition "Extend the protection function of motor working range setting"	
	(No change in this document)		6) Function addition "Support of electronic gear to single-turn absolute function/ininitely rotatable absolute function"	
	P96		7) Function addition "Pause function of profile operation"	
	P76,79,81,82,84,85,86		8) Function addition "Extend the RTEX alarm command function"	
	(No change in this document)		9) Function addition "Extend the settable range of electronic gear"	
	P36,P44,P106,P187		10) Function addition "Extend the RANATERM command function during the establishment of RTEX communication"	
	P102-P104,P110		11) Function addition "Extend the data of RTEX monitor command"	
	(No change in this document)		12) Function addition "Extend the data of front panel display"	
	P94,P115,P161-P162,P166,P182		13) Function addition "Extend the profile homing function"	
	(No change in this document)		14) Function addition "Extend the data of monitor signal output function"	

Note: The page number (Page) is the current page number at the time of revision.

Revisions

Date	Page	Rev.	Description	Signed
	P9,10,44,51,53-56,63,67,68,72,80,94-95,101,102,103,104,106,115,117,120,123,129,136,138,167,129,136,138,167		15) Function addition "Full-closed control"	
	P107,P108		16) Function addition "Safety function"	
	P9,P10,P31,P67		17) Function addition "External scale position information monitor function under semi-closed control"	
	(No change in this document)		18) Function addition "Hybrid vibration suppression function"	
	P12,P33		• Addition Added the description of the setting of Update_Counter.	
	P12		• Addition Added the precautions about the timing of operation command setting	
	P44		• Addition Added the description of Homing_Complete.	
	P67		• Correction Corrected the support of ABS latch start to semi-closed control.	
	P73		• Addition Added the precautions about clearing the values of Latch_Comp1 and Latch_Comp2.	
	P101		• Addition Added the precautions about regenerative load ratio.	
	P143,P149		• Addition Added the precautions when infinitely rotatable absolute function is effective.	
	P167		• Addition Added the precautions in the two-degree-of-freedom control.	
	P184,P185,P186		•Correction Corrected to set bits to 1 when disabling the warning.	
Apr. 14, 2017	P77, P78, P80	3.1	•Addition Added the change in specifications for response alarm codes/warning codes with the alarm command.	
	P80		•Addition Added error clear for external scale.	
	Overall		• Corrected all incorrect entries.	
June. 9, 2017	P4	4.0	Software upgrade CPU1 Ver1.20 -> Ver1.21 CPU2 Ver1.20 -> Ver1.21	
	P142		1) Function addition "Extension of the range of absolute data"	
	P16		2) Function addition "Functional extension of RTEX communication setting"	
	P94, P95, P112, P119		3) Function addition "Addition of RTEX monitor data"	
	P93		• Addition Added "13h: Warning flag". Added notes *2) and *3).	
	P111		• Addition Added "A6h: Speed deviation" and "B3h: Deterioration diagnosis torque command standard value". Added note *3.	
	P109		• Change Added Note*2) to the unit of regenerative load factor.	
	P5		• Addition Added (4) and (5) in <IMPORTANT>.	
	P6-P10		• Addition Added the description of differences from the MINAS-A5N series,	
	P75		• Addition Added precautions for homing operation.	
	P79		• Addition Added a description in the explanation of the latch mode.	
	P80		• Addition Added the timing chart of the latch mode completion state.	
	P88, P89		• Addition Added a note on alarm accessory information read.	
	P149		• Addition Added a description in <IMPORTANT>.	
	P5		• Correction Corrected the notes on references in "Related documentation".	
	P109		• Delete Deleted the notes on incremental mode for mechanical angle.	
	Overall		• Corrected all incorrect entries.	

Note: The page number (Page) is the current page number at the time of revision.

Revisions

Date	Page	Rev.	Description	Signed
July 10, 2017	P4	5.0	Software upgrade CPU1 Ver1.21 -> Ver1.22 CPU2 Ver1.21 -> Ver1.22	
	P70		1) Function change "Expansion in range of the manufacturing number indication function"	
	P1, P4, P6, P9, P51, P73, P74, P82toP85, P128, P150toP152, P189, P201		2) Function addition "Latch mode with stop function"	
	P73, P77		3) Function addition "Expansion of the range for actual position setting/command position setting"	
May 31, 2018	P5	6.0	Software upgrade CPU1 Ver1.22 → Ver1.23 CPU2 Ver1.22 → Ver1.23	
	P9,P86-P89, P133,P156-P159		1) Function change "Function extension of latch mode with stop function"	
	P1,P9,P11,P37, P42,P49,P52,P54, P55,P124,P125, P133,165		2) Function addition "Retreat operation function"	
	P1,P9,P37,P42, P52-P54,P70,P78, P115,P120,P130, P131,P134,P208		3) Function addition "Virtual full-closed control mode function"	
	P6,P9,P208		4) Function addition "Torque control under two-degrees-of-freedom control"	
	P9,		5) Function change "Extension of Pr5.09 (Main power supply off detection period) setup range"	
	P9,		6) Function change "Extension of Pr6.35 (Hybrid vibration suppression filter) setup range"	
	P78,P142,P209		7) Function change "Alarm change at return to origin command cancellation"	
	Overall		• Corrected all incorrect entries.	

Note: The page number (Page) is the current page number at the time of revision.

Contents

1. Introduction	1
1-1 Main differences from the MINAS-A5N series	7
2. Configuration and Initialization of RTEX Communication System.....	12
2-1 Outline	12
2-2 System structure	12
2-3 Basic specifications of network	13
2-4 Node address (MAC-ID) setting and front panel configuration	14
2-5 Communication cycle/command updating cycle, control mode and data size setup	15
2-5-1 Mode reference table	16
2-5-2 Related Parameter.....	17
2-5-3 Example of mode setup	18
2-6 COM LED, LINK LED and RTEX communication state	19
3. Transmission Protocol of RTEX Communication Data	20
3-1 Transmission timing of data	20
3-1-1 Transmission timing of communication period 0.0625 ms/command updating period 0.125 ms	21
3-1-2 Transmission timing of communication cycle 0.125 ms/command updating cycle 0.125 ms	21
3-1-3 Transmission timing of communication cycle 0.125 ms/command updating cycle 0.250 ms	22
3-1-4 Transmission timing of communication period 0.250 ms/command updating period 0.250 ms	22
3-1-5 Transmission timing of communication cycle 0.250 ms/command updating cycle 0.5 ms	23
3-1-6 Transmission timing of communication period 0.5 ms/command updating period 0.5 ms.....	23
3-1-7 Transmission timing of communication cycle 0.5 ms/command updating cycle 1.0 ms	24
3-1-8 Transmission timing of communication period 1.0 ms/command updating period 1.0 ms.....	24
3-1-9 Transmission timing of communication cycle 1.0 ms/command updating cycle 2.0 ms	25
3-1-10 Transmission timing of communication period 2.0 ms/command updating period 2.0 ms	25
3-1-11 Transmission timing of communication cycle 2.0 ms/command updating cycle 4.0 ms	26
3-2 Transmission of cyclic data	27
3-2-1 Cyclic transmission area.....	27
3-3 Transmission of Non-Cyclic Data	28
3-3-1 Non-cyclic transmission area.....	28
3-3-2 Non-cyclic status flag.....	29
3-3-3 Non-cyclic command startup mode setting	30
3-3-4 Startup of non-cyclic command (MINAS-A4N compatible mode)	31
3-3-4-1 Basic sequence of non-cyclic command	32
3-3-4-2 Read sequence of non-cyclic command.....	33
3-3-4-3 Write sequence of non-cyclic command	34
3-3-5 Startup of non-cyclic command (extend mode).....	35

4. RTEX Communication Data Block	36
4-1 Transmission and reception memory in the RTEX communication IC	36
4-2 Command data block arrangement (16-byte/32-byte mode)	37
4-2-1 Command code and command argument (Command bytes 1, 4–15)	38
4-2-1-1 TMG_CNT setup and inter-axis synchronous mode	39
4-2-2 Command header (command byte 0)	41
4-2-2-1 Update_Counter setup	41
4-2-3 Control bit (Command Bytes 2 and 3)	42
4-2-3-1 Servo_On/off command (Servo_on)	43
4-2-3-2 Gain switching command (Gain_SW)	45
4-2-3-3 Torque limit switching command (TL_SW)	46
4-2-3-4 Speed limit switching command (SL_SW)	47
4-2-3-5 External output signal operation instruction (EX-OUT 1/2)	48
4-3 Data block in response (16-byte/32-byte)	49
4-3-1 Command_Code_Echo and Response_Data (Response byte 1, 4 to 15)	50
4-3-2 Response header (Response byte 0)	51
4-3-3 Status flag (Response byte 2)	52
4-3-3-1 Servo Ready state (Servo_Ready)	54
4-3-3-2 Internal position command generation state (In_Progress)/main power off alarm state (AC_OFF)	54
4-3-4 Input signal status flag (Response byte 3)	55
4-4 Command data block of sub-command (only for 32-byte mode)	56
4-4-1 Sub-command code and sub-command argument (Command bytes 16 to 31)	57
4-5 Response data block of sub-command (only for 32-byte mode)	58
4-5-1 Sub-command code echo and response data (Command bytes 16 to 31)	59
5. Cyclic Command Description	60
5-1 Cyclic command list	60
5-2 NOP command (Command code: 0□h)	61
5-3 Profile position control (PP) command (Command code: 1□h)	62
5-4 Cyclic position control (CP) command (Command code: 2□h)	63
5-5 Cyclic velocity control (CV) command (Command code: 3□h)	64
5-6 Cyclic torque control (CT) command (Command code: 4□h)	65
6. Non-cyclic Command Description	66
6-1 Non-cyclic command list	66
6-2 Normal command (Command code: □0h)	67
6-3 Reset Command (Command code: □1h)	68
6-3-1 Software reset mode (Type_Code: 001h)	69
6-3-2 Attribute C parameter validation mode (Type_Code: 011h)	70
6-4 System ID Command (Command code: □2h)	71
6-4-1 System ID command Type_Code list	72
6-4-2 Example of reading of vendor name (“Panasonic”)	73
6-4-3 Device type	73
6-4-4 Servo driver software version	74
6-4-5 Servo driver type	74

6-5 Homing command (Command code: □4h).....	75
6-5-1 Type Code list of Homing Command	76
6-5-2 Assignment of external input signals related to return to home sequence	79
6-5-3 Actual position setup and command position setup	80
6-5-4 Latch mode.....	82
6-5-4-1 Starting/canceling latch mode	82
6-5-4-2 Selecting latch trigger signal.....	83
6-5-4-3 Checking latch mode complete status and latch position data	84
6-5-4-4 Correction function for detection delay of latch position.....	85
6-5-5 Latch mode with stop function	86
6-5-5-1 Starting up, cancellation and termination of latch mode with stop function	88
6-5-5-2 Selection of latch trigger signal with stop function.....	89
6-5-5-3 State of latch mode with stop function and check on latch position data	90
6-6 Alarm command (Command code: □5h).....	91
6-6-1 Alarm command Type_Code list	93
6-6-2 Setting up of alarm code	99
6-6-3 Alarm attribute.....	99
6-6-4 Multiple alarm/warning information	100
6-6-5 Alarm accessory information.....	102
6-7 Parameter Command (Command code: □6h).....	103
6-7-1 Type code list of parameter command	104
6-7-2 Parameter number of MINAS-A5N/A6N series.....	106
6-7-4 Parameter attribute of MINAS-A6N series	107
6-7-5 Protecting parameter writing/EEPROM writing through RTEX	107
6-8 Profile command (Command code: 17h).....	108
6-8-1 Profile command Type_Code list	110
6-8-2 Selection of latch trigger signal for positioning profile position latch.....	111
6-8-3 Checking latch mode complete status and latch position data	111
6-8-4 Stop command.....	112
6-8-5 Profile positioning neighborhood output (NEAR).....	113
6-8-6 Software limit (PSL/NSL).....	114
6-8-7 Other precautions related to profile command.....	115
6-9 Monitor Command (Command Code: □Ah)	116
6-9-1 Type code list of monitor command	117
6-9-2 Cause of no revolution	122
6-9-3 Assignment of the warning flag.....	123
6-9-4 Position information during servo off, velocity control and torque control.....	123
6-9-5 Status of input and output signals	124
6-9-6 Multiple alarm/warning information	127
6-9-7 Function for reading control mode and absolute setting	128
6-10 Command error (Command code: □□h).....	129
6-10-1 Command error detection	130
6-10-1-1 Command error common to 16-byte and 32-byte modes.....	130
6-10-1-2 Command error in 32-byte mode.....	132
6-10-2 List of command error code.....	133
6-11 Communication Error (Command code: □□h/ Response code: FFh).....	135

7. Operation.....	136
7-1 Cyclic position control (CP) operation	136
7-1-1 Command follow-up process (command position at servo-off).....	136
7-1-2 Prohibited matter of NOP command (0□h)	137
7-1-3 Command position upon communication error	137
7-1-4 Variations in command position during command updating period.....	138
7-1-4-1 Limiting variations in command position	138
7-1-4-2 Wrap rounding command position	138
7-1-4-3 Clearing position deviations	138
7-1-4-4 Amount of change saturation function of command position.....	139
7-2 Homing operation	141
7-2-1 Normal return-to-home sequence in cyclic position control (CP) mode.....	142
7-2-2 Sequence of actual position/command position setup	144
7-2-3 Example of cyclic homing operation	146
7-2-3-1 Example of cyclic homing operation 1	147
7-2-3-2 Example of cyclic homing operation 2	149
7-2-3-3 Example of cyclic homing operation 3	150
7-2-3-4 Example of cyclic homing operation 4	151
7-2-4 Initialization of the absolute encoder.....	152
7-2-4-1 Absolute data	152
7-2-4-2 Clearing multi-turn data.....	155
7-2-5 Sequence for latch mode with stop function.....	156
7-2-5-1 Example of latch mode with stop function.....	160
7-3 Cyclic velocity control (CV) operation	161
7-4 Cyclic torque control (CT) operation	163
7-5 Profile position control (PP) operation	165
7-5-1 Profile position control (PP) related parameter	165
7-5-2 Profile absolute positioning (Type_Code: 10h)	166
7-5-3 Profile relative positioning (Type_Code: 11h).....	169
7-5-4 Profile position latch absolute positioning (Type_Code: 12h).....	172
7-5-5 Profile position latch relative positioning (Type_Code: 13h)	175
7-5-6 Profile continuous revolution (JOG) (Type_Code: 20h).....	176
7-5-7 Profile homing 1 (HOME + Z phase) (Type_Code: 31h)	178
7-5-8 Profile homing 2 (HOME) (Type_Code: 32h).....	180
7-5-9 Profile homing 3 (Z phase) [Type_Code: 33h]	182
7-5-10 Profile homing 4 (POT/NOT + HOME) (Type_Code: 34h)	184
7-5-11 Profile homing 6 (POT/NOT + Z phase) (Type_Code: 36h)	186
7-5-12 Precautions for profile position control operation	188
7-6 Control mode switching	190
7-6-1 Control mode switching method.....	190
7-6-2 Precautions for control mode change during operation	191
7-6-3 Other precautions related to control mode switching	192
7-7 Feedforward function	193
7-7-1 Feedforward function validation parameter and command area to be used	193
7-7-2 Setting unit and setting range	195
7-7-3 Compatible control mode	195
7-7-4 Other precautions related to feedforward function	196

8. RTEX Communication Related Protective Function and Troubleshooting.....	197
8-1 RTEX communication related protective function	197
8-1-1 PLL incomplete error protection (Err80.3).....	198
8-1-2 RTEX node address setting error protection (Err82.0)	199
8-1-3 RTEX continuous communication error protection 1 (Err83.0)	200
8-1-4 RTEX continuous communication error protection 2 (Err83.1)	201
8-1-5 RTEX time out error protection (Err84.0)	202
8-1-6 RTEX synchronization error protection (Err84.3)	203
8-1-7 RTEX communication cycle error protection (Err84.5)	204
8-1-8 RTEX cyclic data error protection 1/2 (Err86.0/Err86.1)	205
8-1-9 RTEX_Update_Counter error protection (Err86.2)	206
8-1-10 RTEX interaxis sync establishment error protection (Err90.2).....	207
8-1-11 RTEX command error protection (Err91.1).....	208
8-1-12 RTEX command error protection 2 (Err91.3).....	209
8-1-13 RTEX hardware error protection 1/2/3 (Err98.1/Err98.2/Err98.3)	210
8-2 RTEX communication warnings	211
8-2-1 RTEX continuous communication error warning (WngC0h)	211
8-2-2 RTEX accumulated communication error warning (WngC1h).....	212
8-2-3 RTEX Update_Counter error warning (WngC2h).....	213
8-2-4 PANATERM command execution warning (WngD2h).....	214
8-3 Locating disconnection point of network cable	215

1. Introduction

This technical reference describes the specifications of the network interface “Realtime Express (RTEX)” which connects the driver MINAS-A6N series to the host controller.

<MINAS-A6 series Functional comparison>

○:Usable ×:Not usable

Function		Product	[A6NE] (Standard type) Product number ending with: E	[A6NF] (Multi-function type) Product number ending with: F
			CPU1:Ver1.23 CPU2:Ver1.23	CPU1:Ver1.23 CPU2:Ver1.23
Control mode	Position control(CP)		○	○
	Position control(PP)		○	○
	Velocity control(CV)		○	○
	Torque control(CT)		○	○
	Full-closed control(CP)		×	○
	Full-closed control(PP)		×	○
Function	Two-degree-of-freedom control (Position)		○	○
	Two-degree-of-freedom control (Velocity)		○	○
	Two-degree-of-freedom control (Full-closed)		×	○
	Safety function		×	○
	Vibration control		○	○
	Model type damping filter		○	○
	Feed forward function		○	○
	Load change suppression control		○	○
	Third gain switching function		○	○
	Friction torque compensation		○	○
	Hybrid vibration suppression function		×	○
	Quadrant projection suppressionfu nction		○	○
	Torque limit switching function		○	○
	Motor movable range setting function		○	○
	Torque saturation protection function		○	○
	Single-turn absolute function		○	○
	Infinitely rotatable absolute function		○	○
	External scale position information monitor function under semi-closed control		×	○
	Latch mode with stop function		○	○
	Retreat operation function		○	○
Virtual full-closed control mode function		×	○	

- [A6NF] : All functions described in this reference can be used.
- [A6NE] : There are some functions that cannot be used.
Where applicable, these items are indicated with “Cannot be used in [A6NE]” in the descriptions contained in this reference for your confirmation.

<Software version>

This technical reference applies to the servo drivers of the following software version:

*Please check the software version by setup support software PANATERM or RTEX communication command.

Software version	Contents of function change	Available PANATERM						
CPU1 Ver1.04 CPU2 Ver1.01	First edition	6.0.0.6 or later						
CPU1 Ver1.05 CPU2 Ver1.02	Function extended edition 1 <table border="1" data-bbox="443 481 1318 645"> <thead> <tr> <th>Additional capability</th> <th>Reference</th> </tr> </thead> <tbody> <tr> <td>1) Extend the quadrant projection suppression function</td> <td>SX-DSV03077 5-2-13, 8-1</td> </tr> <tr> <td>2) Correction function for detection delay of latch position</td> <td>This document 6-5-4-4</td> </tr> </tbody> </table>	Additional capability	Reference	1) Extend the quadrant projection suppression function	SX-DSV03077 5-2-13, 8-1	2) Correction function for detection delay of latch position	This document 6-5-4-4	6.0.0.8 or later
Additional capability	Reference							
1) Extend the quadrant projection suppression function	SX-DSV03077 5-2-13, 8-1							
2) Correction function for detection delay of latch position	This document 6-5-4-4							

(To be continued)

Software version	Contents of function change	Available PANATERM																																						
CPU1 Ver1.20 CPU2 Ver1.20	Function extended edition 2	6.0.0.9 or later																																						
	<table border="1"> <thead> <tr> <th data-bbox="368 286 1038 324">Additional capability</th> <th data-bbox="1038 286 1315 324">Reference</th> </tr> </thead> <tbody> <tr> <td data-bbox="368 324 1038 479">1) Deterioration diagnosis warning function</td> <td data-bbox="1038 324 1315 479">This document 6-9-2, 6-9-3 2-2, 2-4-2, 6-8, 7-3, 9-1 SX-DSV03077 2-2, 2-4-2, 6-8, 7-3, 9-1</td> </tr> <tr> <td data-bbox="368 479 1038 544">2) Slow stop function</td> <td data-bbox="1038 479 1315 544">SX-DSV03077 6-3-7, 9-1</td> </tr> <tr> <td data-bbox="368 544 1038 609">3) Dynamic brake (DB) operation function by I/O.</td> <td data-bbox="1038 544 1315 609">SX-DSV03077 2-1, 2-4, 6-3-3, 9-1</td> </tr> <tr> <td data-bbox="368 609 1038 674">4) Battery refresh function</td> <td data-bbox="1038 609 1315 674">SX-DSV03077 4-7-1-4</td> </tr> <tr> <td data-bbox="368 674 1038 739">5) Extend the protection function of motor working range setting</td> <td data-bbox="1038 674 1315 739">SX-DSV03077 6-2, 9-1</td> </tr> <tr> <td data-bbox="368 739 1038 804">6) Support of electronic gear to single-turn absolute function/ infinitely rotatable absolute function</td> <td data-bbox="1038 739 1315 804">SX-DSV03077 6-6, 6-7</td> </tr> <tr> <td data-bbox="368 804 1038 869">7) Pause function of profile operation</td> <td data-bbox="1038 804 1315 869">This document 6-8-4</td> </tr> <tr> <td data-bbox="368 869 1038 934">8) Extend the RTEX alarm command function</td> <td data-bbox="1038 869 1315 934">This document 6-6, 6-6-4, 6-6-5</td> </tr> <tr> <td data-bbox="368 934 1038 999">9) Extend the settable range of electronic gear</td> <td data-bbox="1038 934 1315 999">SX-DSV03077 1-2, 4-2-2, 7-2</td> </tr> <tr> <td data-bbox="368 999 1038 1108">10) Extend the RANATERM command function during the establishment of RTEX communication</td> <td data-bbox="1038 999 1315 1108">This document 4-2-3, 4-3-3, 6-9-3 SX-DSV03077 7-3, 9-1</td> </tr> <tr> <td data-bbox="368 1108 1038 1173">11) Extend the data of RTEX monitor command</td> <td data-bbox="1038 1108 1315 1173">This document 6-9-1, 6-9-6</td> </tr> <tr> <td data-bbox="368 1173 1038 1238">12) Extend the data of front panel display</td> <td data-bbox="1038 1173 1315 1238">SX-DSV03077 3-2</td> </tr> <tr> <td data-bbox="368 1238 1038 1303">13) Extend the profile homing function</td> <td data-bbox="1038 1238 1315 1303">This document 7-5-11</td> </tr> <tr> <td data-bbox="368 1303 1038 1368">14) Extend the data of monitor signal output function</td> <td data-bbox="1038 1303 1315 1368">SX-DSV03077 3-4</td> </tr> <tr> <td data-bbox="368 1368 1038 1603">15) Full-closed control</td> <td data-bbox="1038 1368 1315 1603">This document 2-5-1, 2-5-2, 6-4-1, 6-5-1, 6-6-1, 6-8-1, 6-9-1, 6-9-3, 7-2-3-1 SX-DSV03077 2-5, 3-2, 3-4, 4-2-2, 4-2-5, 4-5, 4-7-2, 5-2-4, 5-2-18, 7-1, 7-2, 7-3, 9-1</td> </tr> <tr> <td data-bbox="368 1603 1038 1727">16) Safety function</td> <td data-bbox="1038 1603 1315 1727">This document 6-9-5 SX-DSV03077 3-2, 7-1, 7-2, 8, 9-1</td> </tr> <tr> <td data-bbox="368 1727 1038 1850">17) External scale position information monitor function under semi-closed control</td> <td data-bbox="1038 1727 1315 1850">This document 2-5-2, 6-6-1 SX-DSV03077 2-5, 4-2-5, 4-8, 9-1</td> </tr> <tr> <td data-bbox="368 1850 1038 1915">18) Hybrid vibration suppression function</td> <td data-bbox="1038 1850 1315 1915">SX-DSV03077 5-2-13, 9-1</td> </tr> </tbody> </table>		Additional capability	Reference	1) Deterioration diagnosis warning function	This document 6-9-2, 6-9-3 2-2, 2-4-2, 6-8, 7-3, 9-1 SX-DSV03077 2-2, 2-4-2, 6-8, 7-3, 9-1	2) Slow stop function	SX-DSV03077 6-3-7, 9-1	3) Dynamic brake (DB) operation function by I/O.	SX-DSV03077 2-1, 2-4, 6-3-3, 9-1	4) Battery refresh function	SX-DSV03077 4-7-1-4	5) Extend the protection function of motor working range setting	SX-DSV03077 6-2, 9-1	6) Support of electronic gear to single-turn absolute function/ infinitely rotatable absolute function	SX-DSV03077 6-6, 6-7	7) Pause function of profile operation	This document 6-8-4	8) Extend the RTEX alarm command function	This document 6-6, 6-6-4, 6-6-5	9) Extend the settable range of electronic gear	SX-DSV03077 1-2, 4-2-2, 7-2	10) Extend the RANATERM command function during the establishment of RTEX communication	This document 4-2-3, 4-3-3, 6-9-3 SX-DSV03077 7-3, 9-1	11) Extend the data of RTEX monitor command	This document 6-9-1, 6-9-6	12) Extend the data of front panel display	SX-DSV03077 3-2	13) Extend the profile homing function	This document 7-5-11	14) Extend the data of monitor signal output function	SX-DSV03077 3-4	15) Full-closed control	This document 2-5-1, 2-5-2, 6-4-1, 6-5-1, 6-6-1, 6-8-1, 6-9-1, 6-9-3, 7-2-3-1 SX-DSV03077 2-5, 3-2, 3-4, 4-2-2, 4-2-5, 4-5, 4-7-2, 5-2-4, 5-2-18, 7-1, 7-2, 7-3, 9-1	16) Safety function	This document 6-9-5 SX-DSV03077 3-2, 7-1, 7-2, 8, 9-1	17) External scale position information monitor function under semi-closed control	This document 2-5-2, 6-6-1 SX-DSV03077 2-5, 4-2-5, 4-8, 9-1	18) Hybrid vibration suppression function	SX-DSV03077 5-2-13, 9-1
	Additional capability		Reference																																					
	1) Deterioration diagnosis warning function		This document 6-9-2, 6-9-3 2-2, 2-4-2, 6-8, 7-3, 9-1 SX-DSV03077 2-2, 2-4-2, 6-8, 7-3, 9-1																																					
	2) Slow stop function		SX-DSV03077 6-3-7, 9-1																																					
	3) Dynamic brake (DB) operation function by I/O.		SX-DSV03077 2-1, 2-4, 6-3-3, 9-1																																					
	4) Battery refresh function		SX-DSV03077 4-7-1-4																																					
	5) Extend the protection function of motor working range setting		SX-DSV03077 6-2, 9-1																																					
	6) Support of electronic gear to single-turn absolute function/ infinitely rotatable absolute function		SX-DSV03077 6-6, 6-7																																					
	7) Pause function of profile operation		This document 6-8-4																																					
	8) Extend the RTEX alarm command function		This document 6-6, 6-6-4, 6-6-5																																					
	9) Extend the settable range of electronic gear		SX-DSV03077 1-2, 4-2-2, 7-2																																					
	10) Extend the RANATERM command function during the establishment of RTEX communication		This document 4-2-3, 4-3-3, 6-9-3 SX-DSV03077 7-3, 9-1																																					
	11) Extend the data of RTEX monitor command		This document 6-9-1, 6-9-6																																					
	12) Extend the data of front panel display		SX-DSV03077 3-2																																					
	13) Extend the profile homing function		This document 7-5-11																																					
	14) Extend the data of monitor signal output function		SX-DSV03077 3-4																																					
	15) Full-closed control		This document 2-5-1, 2-5-2, 6-4-1, 6-5-1, 6-6-1, 6-8-1, 6-9-1, 6-9-3, 7-2-3-1 SX-DSV03077 2-5, 3-2, 3-4, 4-2-2, 4-2-5, 4-5, 4-7-2, 5-2-4, 5-2-18, 7-1, 7-2, 7-3, 9-1																																					
	16) Safety function		This document 6-9-5 SX-DSV03077 3-2, 7-1, 7-2, 8, 9-1																																					
17) External scale position information monitor function under semi-closed control	This document 2-5-2, 6-6-1 SX-DSV03077 2-5, 4-2-5, 4-8, 9-1																																							
18) Hybrid vibration suppression function	SX-DSV03077 5-2-13, 9-1																																							

(To be continued)

Software version	Contents of function change	Available PANATERM								
CPU1 Ver1.21 CPU2 Ver1.21	Function extended edition 3 <table border="1" data-bbox="368 275 1318 533"> <thead> <tr> <th data-bbox="368 275 1034 304">Additional capability</th> <th data-bbox="1042 275 1318 304">Reference</th> </tr> </thead> <tbody> <tr> <td data-bbox="368 309 1034 360">1) Extension of the range of absolute data</td> <td data-bbox="1042 309 1318 360">This document 7-2-4</td> </tr> <tr> <td data-bbox="368 365 1034 472">2) Functional extension of RTEX communication setting</td> <td data-bbox="1042 365 1318 472">This document 2-5-2 SX-DSV03077 9-1</td> </tr> <tr> <td data-bbox="368 477 1034 528">3) Addition of RTEX monitor data</td> <td data-bbox="1042 477 1318 528">This document 6-7-1, 6-9-1, 6-9-7</td> </tr> </tbody> </table>	Additional capability	Reference	1) Extension of the range of absolute data	This document 7-2-4	2) Functional extension of RTEX communication setting	This document 2-5-2 SX-DSV03077 9-1	3) Addition of RTEX monitor data	This document 6-7-1, 6-9-1, 6-9-7	6.0.1.5 or later
	Additional capability	Reference								
	1) Extension of the range of absolute data	This document 7-2-4								
	2) Functional extension of RTEX communication setting	This document 2-5-2 SX-DSV03077 9-1								
3) Addition of RTEX monitor data	This document 6-7-1, 6-9-1, 6-9-7									
CPU1 Ver1.22 CPU2 Ver1.22	Function extended edition 4 <table border="1" data-bbox="368 620 1318 981"> <thead> <tr> <th data-bbox="368 620 1034 649">Additional capability</th> <th data-bbox="1042 620 1318 649">Reference</th> </tr> </thead> <tbody> <tr> <td data-bbox="368 654 1034 719">1) Expansion in range of the manufacturing number indication function</td> <td data-bbox="1042 654 1318 719">This document 6-4-1</td> </tr> <tr> <td data-bbox="368 723 1034 913">2) Latch mode with stop function</td> <td data-bbox="1042 723 1318 913">This document 1, 1-1, 4-3-3, 6-5, 6-5-1, 6-5-5, 6-10-2, 7-2-5, 8-1, 8-1-12 SX-DSV03077 1, 1-1, 2-1, 6-9, 7-1, 7-2, 9-1</td> </tr> <tr> <td data-bbox="368 918 1034 981">3) Expansion of the range for actual position setting/ command position setting</td> <td data-bbox="1042 918 1318 981">This document 6-5, 6-5-3</td> </tr> </tbody> </table>	Additional capability	Reference	1) Expansion in range of the manufacturing number indication function	This document 6-4-1	2) Latch mode with stop function	This document 1, 1-1, 4-3-3, 6-5, 6-5-1, 6-5-5, 6-10-2, 7-2-5, 8-1, 8-1-12 SX-DSV03077 1, 1-1, 2-1, 6-9, 7-1, 7-2, 9-1	3) Expansion of the range for actual position setting/ command position setting	This document 6-5, 6-5-3	6.0.1.6 or later
	Additional capability	Reference								
	1) Expansion in range of the manufacturing number indication function	This document 6-4-1								
	2) Latch mode with stop function	This document 1, 1-1, 4-3-3, 6-5, 6-5-1, 6-5-5, 6-10-2, 7-2-5, 8-1, 8-1-12 SX-DSV03077 1, 1-1, 2-1, 6-9, 7-1, 7-2, 9-1								
3) Expansion of the range for actual position setting/ command position setting	This document 6-5, 6-5-3									

(To be continued)

Software version	Contents of function change	Available PANATERM																
CPU1 Ver1.23 CPU2 Ver1.23	Function extended edition 5	6.0.1.10 or later																
<table border="1"> <thead> <tr> <th data-bbox="368 280 1034 309">Additional capability</th> <th data-bbox="1042 280 1316 309">Reference</th> </tr> </thead> <tbody> <tr> <td data-bbox="368 309 1034 421">1) Function extension of latch mode with stop function</td> <td data-bbox="1042 309 1316 421">This document 1-1, 6-5-5, 6-10-2,7- 2-5 SX-DSV03077 1, 1-2, 1-5, 6-9, 9-1</td> </tr> <tr> <td data-bbox="368 421 1034 645">2) Retreat operation function</td> <td data-bbox="1042 421 1316 645">This document 1, 1-1, 4-2, 4-2-3, 4-3, 4-3-3, 4-3-4, 6-9-5, 6-10-2, 7-5-1, 7-6-3 SX-DSV03077 1, 1-6, 2-1, 2-4-1, 2-4-2, 4-2, 4-3, 4-4, 6-3-3,6-10, 7-1, 7-2, 9-1</td> </tr> <tr> <td data-bbox="368 645 1034 869">3) Virtual full-closed control mode function</td> <td data-bbox="1042 645 1316 869">This document 1, 1-1, 4-2, 4-2-3, 4-3-3, 6-3-2, 6-5-1, 6-8-7, 6-9-1, 6-10-1, 6-10-2, 8-1-11 SX-DSV03077 1-2, 1-3, 1-4, 1-5, 4-2-5, 5-2, 5-2-19, 6-2, 6-5, 7-2, 9-1</td> </tr> <tr> <td data-bbox="368 869 1034 981">4) Torque control under two-degrees-of-freedom control</td> <td data-bbox="1042 869 1316 981">This document 5-1-3, 5-2-3, 7-2 SX-DSV03077 4-4, 5-1-3, 5-2-3, 7-2</td> </tr> <tr> <td data-bbox="368 981 1034 1093">5) Extension of Pr5.09 (Main power supply off detection period) setup range</td> <td data-bbox="1042 981 1316 1093">This document 1-1 SX-DSV03077 6-3-3,9-1</td> </tr> <tr> <td data-bbox="368 1093 1034 1205">6) Extension of Pr6.35 (Hybrid vibration suppression filter) setup range</td> <td data-bbox="1042 1093 1316 1205">This document 1-1 SX-DSV03077 5-2-13, 9-1</td> </tr> <tr> <td data-bbox="368 1205 1034 1317">7) Alarm change at return to origin command cancellation</td> <td data-bbox="1042 1205 1316 1317">This document 6-5-1, 7-2-1, 8-1-12 SX-DSV03077 7-2</td> </tr> </tbody> </table>			Additional capability	Reference	1) Function extension of latch mode with stop function	This document 1-1, 6-5-5, 6-10-2,7- 2-5 SX-DSV03077 1, 1-2, 1-5, 6-9, 9-1	2) Retreat operation function	This document 1, 1-1, 4-2, 4-2-3, 4-3, 4-3-3, 4-3-4, 6-9-5, 6-10-2, 7-5-1, 7-6-3 SX-DSV03077 1, 1-6, 2-1, 2-4-1, 2-4-2, 4-2, 4-3, 4-4, 6-3-3,6-10, 7-1, 7-2, 9-1	3) Virtual full-closed control mode function	This document 1, 1-1, 4-2, 4-2-3, 4-3-3, 6-3-2, 6-5-1, 6-8-7, 6-9-1, 6-10-1, 6-10-2, 8-1-11 SX-DSV03077 1-2, 1-3, 1-4, 1-5, 4-2-5, 5-2, 5-2-19, 6-2, 6-5, 7-2, 9-1	4) Torque control under two-degrees-of-freedom control	This document 5-1-3, 5-2-3, 7-2 SX-DSV03077 4-4, 5-1-3, 5-2-3, 7-2	5) Extension of Pr5.09 (Main power supply off detection period) setup range	This document 1-1 SX-DSV03077 6-3-3,9-1	6) Extension of Pr6.35 (Hybrid vibration suppression filter) setup range	This document 1-1 SX-DSV03077 5-2-13, 9-1	7) Alarm change at return to origin command cancellation	This document 6-5-1, 7-2-1, 8-1-12 SX-DSV03077 7-2
Additional capability	Reference																	
1) Function extension of latch mode with stop function	This document 1-1, 6-5-5, 6-10-2,7- 2-5 SX-DSV03077 1, 1-2, 1-5, 6-9, 9-1																	
2) Retreat operation function	This document 1, 1-1, 4-2, 4-2-3, 4-3, 4-3-3, 4-3-4, 6-9-5, 6-10-2, 7-5-1, 7-6-3 SX-DSV03077 1, 1-6, 2-1, 2-4-1, 2-4-2, 4-2, 4-3, 4-4, 6-3-3,6-10, 7-1, 7-2, 9-1																	
3) Virtual full-closed control mode function	This document 1, 1-1, 4-2, 4-2-3, 4-3-3, 6-3-2, 6-5-1, 6-8-7, 6-9-1, 6-10-1, 6-10-2, 8-1-11 SX-DSV03077 1-2, 1-3, 1-4, 1-5, 4-2-5, 5-2, 5-2-19, 6-2, 6-5, 7-2, 9-1																	
4) Torque control under two-degrees-of-freedom control	This document 5-1-3, 5-2-3, 7-2 SX-DSV03077 4-4, 5-1-3, 5-2-3, 7-2																	
5) Extension of Pr5.09 (Main power supply off detection period) setup range	This document 1-1 SX-DSV03077 6-3-3,9-1																	
6) Extension of Pr6.35 (Hybrid vibration suppression filter) setup range	This document 1-1 SX-DSV03077 5-2-13, 9-1																	
7) Alarm change at return to origin command cancellation	This document 6-5-1, 7-2-1, 8-1-12 SX-DSV03077 7-2																	

* A new software version is downward compatible with a old software version.

Parameters used in a old software version can be used in a new software version, as is.

The parameter settings added to the “Function extended edition 1” are the default settings with additional capability invalidated and compatible with the “First edition”.

When using the additional capability, set parameters according to the description of each function in this document.

<Object person>

This document is intended for use by engineers who design a host system that controls the servo driver MINAS-A6N series.

< Related documentation >

SX-DSV03089: Reference specifications

(The specification about hardware, Safety Precautions, Warranty etc. is indicated.

Please be sure to read carefully, After understanding the contents, refer to this specification.)

SX-DSV03077: Technical reference – Functional Specification –

<IMPORTANT>

- All rights reserved. No part of this publication may be reproduced or transmitted in any form without prior permission.
- Motor Business Unit, Panasonic Corp. reserves the right to make modifications and improvements to its products and/or documentation, including specifications and software, without prior notice.
- The MINAS-A6N series have changed the default setting from the previous series, such as to enable the two-degree-of-freedom control mode.
When replacing the previous series to MINAS-A6N series, please note that it is necessary to re-adjust the parameters.
Refer to the Reference specifications for the default settings of MINAS-A6N series.
- Since the shipment value has the two-degrees-of-freedom control mode valid, note that Err91.1 “RTEX command error protection” will occur when torque control mode is set without changing the shipment setting values in function extended version 4 and earlier versions.
- Although the MINAS-A6N series is trying to operate compatible with the previous series(MINAS-A5N series etc), It may not be fully compatible operation.
In the case of replacing the previous series to the MINAS-A6N series, be sure to evaluate.

1-1 Main differences from the MINAS-A5N series

There are mainly the following differences in specifications when comparing the MINAS-A6N series with the MINAS-A5N series.

<SX-DSV03078: Technical reference (RTEX Communication Specifications)>

chapter	function	Description	[A5N](Safety function present) specification	[A6NE] (Standard type) specification	[A6NF] (Multi-function type) specification
			Ver3.06	CPU1:Ver1.23, CPU2:Ver1.23	CPU1:Ver1.23, CPU2:Ver1.23
2-1	Communication cycle/ Command updating cycle	Communication cycle (semi-closed)	83.3us, 166.6us, 500us, 1ms	62.5us, 125us, 250us, 500us, 1ms, 2ms * Only electric gear 1:1 is supported for 250 us and lower.	
		Communication cycle (full-closed)	500us, 1ms	Not supported	500us, 1ms, 2ms
		Command updating cycle (semi-closed)	166.6us, 500us, 1ms	125us, 250us, 500us, 1ms, 2ms, 4ms	
		Command updating cycle (full-closed)	500us, 1ms	Not supported	500us, 1ms, 2ms, 4ms
2-3	Slaves to be connected (axes)	Maximum number of slaves that can be connected	Communication cycle time is 83.3us :Max5 Communication cycle time is 166.6us :Max10 Others :Max32	Communication cycle time is 62.5us :Max4 Communication cycle time is 125us :Max8 Communication cycle time is 250us :Max16 Others :Max32	
2-5-2	RTEX communication setting for PANATERM	Parameter setting/communication state monitor related to RTEX communication from PANATERM	Not supported	Supported	
4-2-3-1	Servo ON command for PANATERM operation	PANATERM operation such as test run operation, FFT, and pin assignment setting while establishing communication	Not supported	Supported	
5-5	Cyclic velocity control (CV) command	Setting range for command velocity	-motor maximum speed to motor maximum speed	-motor maximum speed to motor maximum speed * When speed setting is in r/min, it is converted to command unit/s through internal computation and the equivalent value is limited within the range as shown below. -80000001h~7FFFFFFh(-2147483647~2147483647)	
6-5-4-4	Correction function for detection delay of latch position	Setting the correction time for the delay of the latch trigger signal detection	Not supported	Supported	
6-5-5	Latch mode with stop function	Stops at the latched position in detection of latch trigger signal.	Not supported	Supported * For details, refer to 6-5-5.	
6-6-1	Alarm command	Read out multiple alarm/warning information (Type_Code:004h)	Not supported	Supported	
		Read out present alarm accessory information (Type_Code:0A0h)	Not supported	Supported	
		Read out alarm accessory information of the latest alarm (Type_Code:0A1h)	Not supported	Supported	
		Read out accessory information of alarm that occurred 2 times before (Type_Code:0A2h)	Not supported	Supported	
		Read out accessory information of alarm that occurred 2 times before (Type_Code:0A3h)	Not supported	Supported	
6-7-1	Parameter command	Parameter initial value read-out (Type_Code:020h)	Not supported	Supported	
6-9-1	Monitor command	Monitor data	38 kinds	59 kinds * For details, refer to 6-9-1.	68 kinds * For details, refer to 6-9-1.
7-1-4-4	Amount of change saturation function of command position	Saturating a received excessive command position with the maximum motor speed	Not supported	Supported	
7-2-4	Initialization of the absolute encoder	Effective bit length for multi-turn data at position information initialization	17bit absolute: 15bit 20bit absolute: 12bit	23bit absolute: Max16bit *Dependent on electronic gear ratio * For details, refer to 7-2-4.	
7-5-10	Profile homing	Profile homing 4 (Homing operation using POT/NOT and HOME)	Not supported	Supported	
		Profile homing 6 (Homing operation using POT/NOT and Z phase)	Not supported	Supported	
8-1	RTEX communication related protective function	Err80.3 "PLL incomplete error protection"	Not supported	Supported	
8-2	RTEX communication warnings	WngD2h "PANATERM command execution warning"	Not supported	Supported	

<SX-DSV03077: Technical reference (Functional Specifications)>

chapter	function	Description	[A5N](Safety function present) specification	[A6NE] (Standard type) specification	[A6NF] (Multi-function type) specification
			Ver3.06	CPU1:Ver1.23, CPU2:Ver1.23	CPU1:Ver1.23, CPU2:Ver1.23
1-1	Encoder feedback	Compatible encoders	17bit/20bit absolute encoder 20bit incremental encoder	23bit absolute encoder	
2-1	Input signal function	Dynamic brake (DB) switching input "DB-SEL"	Not supported	Supported	
2-2	Output signal function	Position comparison output "CMP-OUT"	Not supported	Supported	
		Deterioration diagnosis velocity output "V-DIAG"	Not supported	Supported	
3-2	7-segment LED	Overload load rate	Not supported	Supported	
3-4	Monitor signal output function	Analog monitor signal	21 kinds	23 kinds * For details, refer to 3-4.	25 kinds * For details, refer to 3-4.
		Updating cycle	500us	125us	
		Output selecting the unit for command position deviation	Not supported(Command position fixing after filtering)	Supported (Switching the after filtering and the before filtering by Pr7.23 bit14)	
4-2-2	Electronic gear function	Valid range of electric gear specification	1/1000 to 1000	1/1000 to 8000	
4-2-4	Positioning complete output (INP/INP2) function	Position setup unit select	Not supported(Encoder unit fixed)	Supported (Switching the command unit and the encoder unit by Pr5.20)	
4-5-1	Supported speeds for external scale	Serial communications type (increment specification)	-400Mpps	Not supported	-4Gpps
		Serial communications type (absolute specification)	-400Mpps	Not supported	-4Gpps
4-7-1-4	Battery refreshment of the absolute encoder	Battery discharge process (refresh) in USB communication (setup support software)	Not supported	Supported	
4-8	External scale position information monitor function under semi-closed control	External scale position information monitor during semi-closed control by RTEX communication	Supported	Not supported	Supported
5-2-5	Gain Switching Function	Control modes that can be used	Position control, velocity control, torque control, full-closed control	Position control, velocity control, torque control	Position control, velocity control, torque control, full-closed control
5-2-6	Notch filter	Maximum quantity used	4 filters available	5 filters available	
5-2-7	Damping Control	Maximum quantity used	Maximum of 2 (Restricted to 1 during two-degree-of-freedom control)	Maximum of 3 (Restricted to 2 during two-degree-of-freedom control)	Maximum of 3 (Restricted to 2 during full-closed control) (Restricted to 2 during two-degree-of-freedom control)
		Control modes that can be used:	Position control, full-closed control	Position control	Position control, full-closed control
5-2-8	Model-type damping filter	Reducing the vibration by using the model type damping filter to remove the vibration frequency from the position command	Not supported	Supported	
--	Disturbance observer function	Estimating the motor speed using the load model to increase the accuracy of speed detection and to realize both quicker responses and the reduction of shaking at the time of stopping	Supported	Not supported	
5-2-10	Load variation suppression function	Reducing the motor speed variation caused by disturbance torque and load variation to stabilize the operation	Not supported	Supported	
5-2-11	3rd gain switching function	Control modes that can be used:	Position control, full-closed control	Position control	Position control, full-closed control
5-2-12	Friction torque compensation	Control modes that can be used:	Position control, velocity control, full-closed control	Position control, velocity control	Position control, velocity control, full-closed control
5-2-13	Hybrid vibration suppressing function	Control modes that can be used:	Full-closed control	Not supported	Full-closed control
		Extension of Pr6.35 (Hybrid vibration suppression filter) setup range	6400[0.01ms]	Not supported	32000[0.01ms]
5-2-14	Two-stage torque filter	Control modes that can be used:	Position control, velocity control, torque control, full-closed control	Position control, velocity control, Torque control,	Position control, velocity control, torque control, full-closed control
5-2-15	Quadrant projection suppression function	Reducing the quadrant projection that occurs at the time of circular interpolation of two axes or more	Not supported	Supported	

(To be continued)

< SX-DSV03077 : Technical reference (Functional Specifications) >

chapter	function	Description	[A5N](Safety function present) specification	[A6NE] (Standard type) specification	[A6NF] (Multi-function type) specification
			Ver3.06	CPU1:Ver1.23, CPU2:Ver1.23	CPU1:Ver1.23, CPU2:Ver1.23
5-2-16 5-2-17 5-2-18	Two-degree-of-freedom control mode	Factory default setting value of two-degree-of-freedom control	Two-degree-of-freedom control disabled (Factory default value: 0)	Two-degree-of-freedom control enabled (Factory default value: 1)	
		Control modes that can be used:	Position control	Position control, velocity control torque control * * Operation will be similar to that when two-degrees-of-freedom is disabled.	Position control, velocity control torque control * Full-closed control * Operation will be similar to that when two-degrees-of-freedom is disabled.
5-2-19	Virtual full-closed control mode function	There are areas in motor operation range where full-closed system cannot be established, and this is an effective function when operation with semi-closed control is required.	Not supported	Not supported	Supported
6-1	Torque limit switching function	Control modes that can be used:	Position control, velocity control, full-closed control	Position control, velocity control	Position control, velocity control, full-closed control
6-2	Motor working range setup function	Control modes that can be used:	Position control, full-closed control	Position control	Position control, full-closed control
		Extended function of the protection of the motor working range setting(Expansion of effective range for detection)	Not supported	Supported	
6-3-3	Sequence at main power OFF	Dynamic brake operation by a dynamic brake (DB) switching input after stopping	Not supported	Supported	
		Lower limit value for setting range in Pr5.09 "Main power supply off detection period"	70ms	20ms	
6-3-7	Slow stop function	Function of smoothly stopping the motor at emergency stopping	Not supported	Supported	
6-4	Torque saturation protection function	Method of specifying the condition for setting the protection function on	Specifying by 0.1666 ms × count	Specifying by 0.25 ms × count or in ms units	
		Control modes that can be used:	Position control, velocity control, full-closed control	Position control, velocity control	Position control, velocity control, full-closed control
6-5	Position comparison output function	Outputting a pulse signal as a general output or from the encoder output pin when the actual position passes the parameter setting position	Not supported	Supported	
6-7	Continuous rotating absolute encoder	Setting any value as the upper limit of the absolute encoder multi-turn data	Not supported	Supported	
6-8	Deterioration diagnosis warning function	Checking the motor and the connected devices for any property changes to output deterioration diagnosis warnings	Not supported	Supported	
6-9	Latch mode with stop function	The function to stop at the latched position at the timing of latch trigger signal input	Not supported	Supported	
6-10	Retreat operation function	The function to execute retreat operation by the speed and amount of travel specified in parameters when the condition is satisfied	Not supported	Supported	
7-1 7-2	Protective function	Err25.0 "Hybrid deviation excess protection"	Supported	Not supported	Supported
		Err30.0 "Safety input protection"	Supported	Not supported	
		Err36.2 "EEPROM parameter error protection"	Supported	Not supported	
		Err43.0 "Incremental encoder initialization error protection"	Supported	Not supported	
		Err48.0 "Incremental encoder Z-phase error protection"	Supported	Not supported	
		Err49.0 "Incremental encoder CS signal error protection"	Supported	Not supported	
		Err50.0 "External scale connection error protection"	Supported	Not supported	Supported
		Err50.1 "External scale communication error protection"	Supported	Not supported	Supported

(To be continued)

<SX-DSV03077 : Technical reference (Functional Specifications)>

chapter	function	Description	[A5N](Safety function present) specification	[A6NE] (Standard type) specification	[A6NF] (Multi-function type) specification
			Ver3.06	CPU1:Ver1.23, CPU2:Ver1.23	CPU1:Ver1.23, CPU2:Ver1.23
7-1 7-2	Protective function	Err51.0-Err51.5 “External scale ST error protection 0-5”	Supported	Not supported	Supported
		Err55.0 “Phase A connection error protection”	Supported	Not supported	Supported
		Err55.1 “Phase B connection error protection”	Supported	Not supported	Supported
		Err55.2 “Phase Z connection error protection”	Supported	Not supported	Supported
		Err92.1 “External scale date recovery error protection”	Supported	Not supported	Supported
		Err93.2 “Parameter setting error protection 2”	Supported	Not supported	Supported
		Err93.3 “External scale connection error protection”	Supported	Not supported	Supported
		Err15.1 “Encoder overheat error protection”	Not supported	Supported	
		Err31.0-Err31.2 “Safety function error protection 1-2”	Not supported	Not supported	Supported
		Err50.2 “External scale communication data error protection”	Not supported	Not supported	Supported
		Er70.0 “Phase U current detector error protection”	Not supported	Supported	
		Err70.1 “Phase W current detector error protection”	Not supported	Supported	
		Err72.0 “Thermal relay error protection”	Not supported	Supported	
		Err80.3 “PLL incomplete error protection”	Not supported	Supported	
		Err91.3 “RTEX command error protection 2”	Not supported	Supported	
		Err92.3 “Multi-turn data upper-limit value disagreement error protection”	Not supported	Supported	
		Err93.8 “Parameter setting error protection 6”	Not supported	Supported	
		Err94.3 “Home position return error protection2”	Not supported	Supported	
		Err96.2-Err96.7 “Control unit error protection 1-6”	Not supported	Supported	
		Err16.1 “Torque saturation error protection” Occurrence factor	Torque saturated has continued for the period set to Pr 7.16 “Torque saturation error protection frequency”	Torque saturated has continued for the period set to Pr 7.16 “Torque saturation error protection frequency” or Pr6.57 “Torque saturation error protection detection time”.	
Err27.6 “Operation commands contention protection” Occurrence factor	FFT operated only by the driver: RTEX communication was established during trial run.	<ul style="list-style-type: none"> When Pr7.99 bit0 = 0, RTEX communications established during test run of FFT operating on the amplifier alone. When Pr7.99 bit0 = 1, servo ON command by RTEX communications received during test run of FET operating on the amplifier alone. 			
Err34.0 “Software limit protection” Occurrence factor	Not supported	Add the following occurrence factors Detection of Err34.0 if Pr6.97 “function expansion setup 3” bit2 = 1, even in the range where detection of Err34.0 is disabled. * For details, refer to 6-2.			

(To be continued)

<SX-DSV03077: Technical reference (Functional Specifications)>

chapter	function	Description	[A5N](Safety function present) specification	[A6NE] (Standard type) specification	[A6NF] (Multi-function type) specification
			Ver3.06	CPU1:Ver1.23, CPU2:Ver1.23	CPU1:Ver1.23, CPU2:Ver1.23
7-1 7-2	Protective function	Err83.0 “RTEX continues communication error protection 1” Occurrence factor	An error (CRC error) with reading data received by a local node continued for a specified period.	Error (CRC error) detection for the read of receive data sent to the node itself continued for the number of times set for Pr7.95 “Number of RTEX continuous communication error protection 1 detections”.	
		Err83.1 “RTEX continues communication error protection 2” Occurrence factor	An error with the reading data received by a local node continued for a specified period.	Error detection for the read of receive data sent to the node itself continued for the number of times set for Pr7.96 “Number of RTEX continuous communication error protection 2 detections”.	
		Err84.0 “RTEX communication timeout error protection” Occurrence factor	No communication data was received and no signal to start receive interrupt handling was received from MNM1221 (RTEX communication control ASIC) for a specified period.	The condition, in which the receive interrupt startup signal was not output from the RTEX communication IC with no reception of communication data, continued for the number of times set for Pr7.97 “Number of RTEX communication timeout error protection detections”.	
		Err86.0 “RTEX cyclic data error protection 1” Occurrence factor	A problem with the data (C/R and MAC-ID) in the cyclic command area, or a problem with the Sub_Chk in 32-byte mode continued for a specified period.	The condition, in which there is an error in cyclic command area data (C/R, MAC-ID) or there is an error in Sub_Chk during 32-byte mode, continued for the number of times set for Pr7.98 “Number of RTEX cyclic data error protection 1/2 detections”.	
		Err86.1 “RTEX cyclic data error protection 2” Occurrence factor	A problem with cyclic command code continued for a specified period.	The condition, in which there is an error in the cyclic command code, continued for the number of times set for Pr7.98 “Number of RTEX cyclic data error protection 1/2 detections”.	
		Err85.0 Retracting operation completion (I/O)	Not supported	Supported	
		Err85.2 Retracting operation error	Not supported	Supported	
		Err87.1 Retracting operation completion (I/O)	Not supported	Supported	
		Err87.3 Retracting operation error	Not supported	Supported	
7-3	Alarm function	WngACh “Deterioration diagnosis warning”	Not supported	Supported	
		WngD2h “PANATERM command execution warning”	Not supported	Supported	
8-1	safe torque off (STO) function	Performance level	SIL2	Not supported	SIL3
		Safety integrity level	Pld (Category 3)	Not supported	Ple (Category 3)
		The state when STO function is activated.	Alarm state Occurrence of Err30.0	Not supported	Safety state(Alarm does not occur.) Front panel display is “St”.
		Restoration method	Restoration with alarm clear after cancellation of STO command	Not supported	Restoration with STO command cancellation after turning OFF the servo command

2. Configuration and Initialization of RTEX Communication System

2-1 Outline

The MINAS-A6N series is a servo driver equipped with an RTEX communication IC that functions in combination with a 100BASE-TX PHY (physical layer chip) compliant with IEEE 802.3.

A ring connection of a master (host device) and slave (MINAS-A6N series, etc.) equipped with an RTEX communication IC comprises a master/slave type 100 Mbps real-time communication system suitable for multi-axis servo control.

2-2 System structure

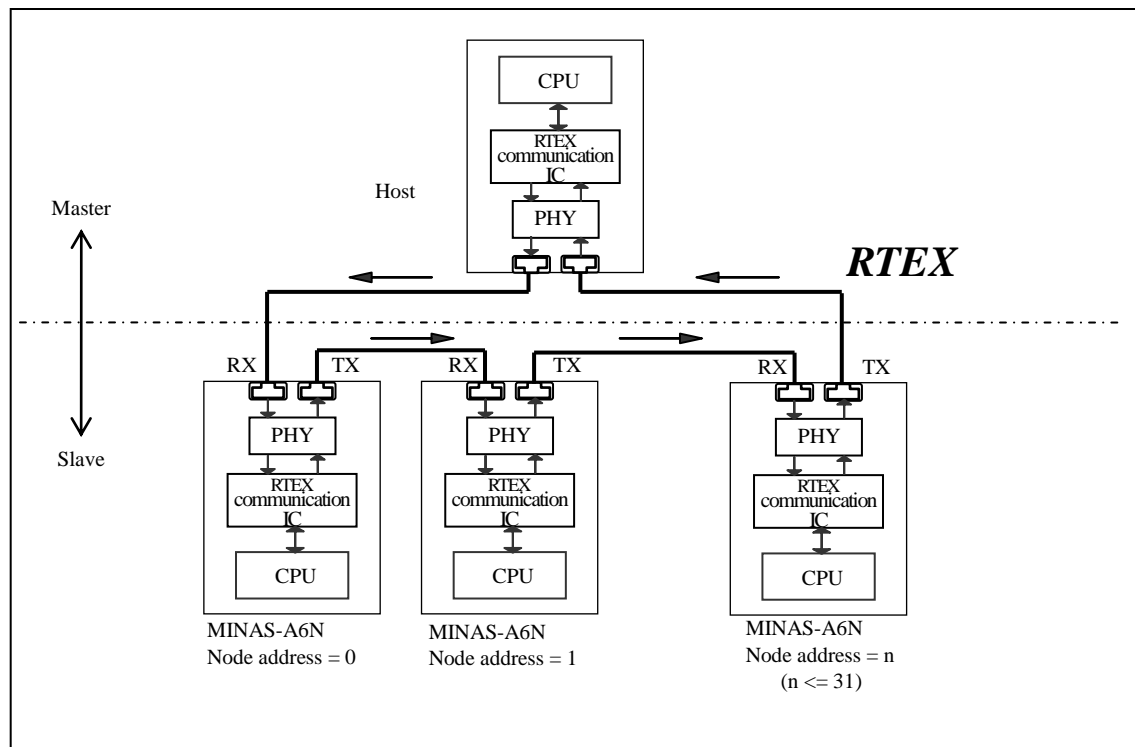

Node address is the ID (MAC-ID) used to identify the slave on the network, and set up with the rotary switch (RSW) on the front panel.

For the master produced by using the sample code provided by us, the node address setting procedure shown in the figure above will not be required.

Notes:

- A Hub required in standard 100BASE-TX is not used because of ring topology.
- In the above figure, pulse transformer which is connected between PHY and connector and other components are omitted.
- Use the STP (shield twisted pair) cable of Category-5e or upper specified by TIA/EIA-568 Standards for the communication cable.

For details of wiring, refer to Reference Specification.

2-3 Basic specifications of network

The following describes the basic specifications of the network interface.

Item	Specifications
Topology	Ring
Physical layer	100BASE-TX (IEEE 802.3)
Baud rate	100 [Mbps]
Network Status LED	[COM], [LINK] 2 units
Setup of node address (MAC-ID)	Rotary switch (2-digit) on the front panel Setup range: 0 to 31 (Default 0)
Communication cycle (physical data transfer cycle)	0.0625, 0.125, 0.250, 0.5, 1, 2 [ms]
Command update period	0.125, 0.250, 0.5, 1, 2, 4 [ms]
Control mode	PP: Profile position mode CP: Cyclic position mode CV: Cyclic velocity mode CT: Cyclic torque mode
Connecting cable	STP (shield twisted pair) cable conforming to category 5e or more of TIA/EIA-568 standards. Note: Use the straight wiring.
Cable length	a) Inter nodes: Max. 100 [m] b) Total: Max. 200 [m] Note: Use within the range which satisfied both of the above conditions. Consult with us when you use exceeding the above b) condition.
Slaves to be connected (axes)	Max. 4 when communication cycle time is 0.0625 ms Max. 8 when communication cycle time is 0.125 ms Max. 16 when communication cycle time is 0.250 ms Max. 32 when communication cycle time is 0.5, 1.0 or 2.0 ms Notes: <ul style="list-style-type: none"> • Number of axes when all connected axes are in 16-byte mode. When in the 32-byte mode, the number of axes connected is one half that of axes connected in the 16-byte mode because the number of transmit-receive data blocks is twice that required in the 16-byte mode. • These figures depend on the arithmetic processing power of the host device. • For the use with the same communication system as the MINAS-A5N series, set the communication cycle to the same cycle (0.5 ms or 1.0 ms) as A5N.
Data size	16-byte mode: Transmit/receive 32-byte mode: Transmit/receive
Communication error detection	CRC-CCITT

2-4 Node address (MAC-ID) setting and front panel configuration

The figure below shows the front panel configuration of MINAS-A6N series.

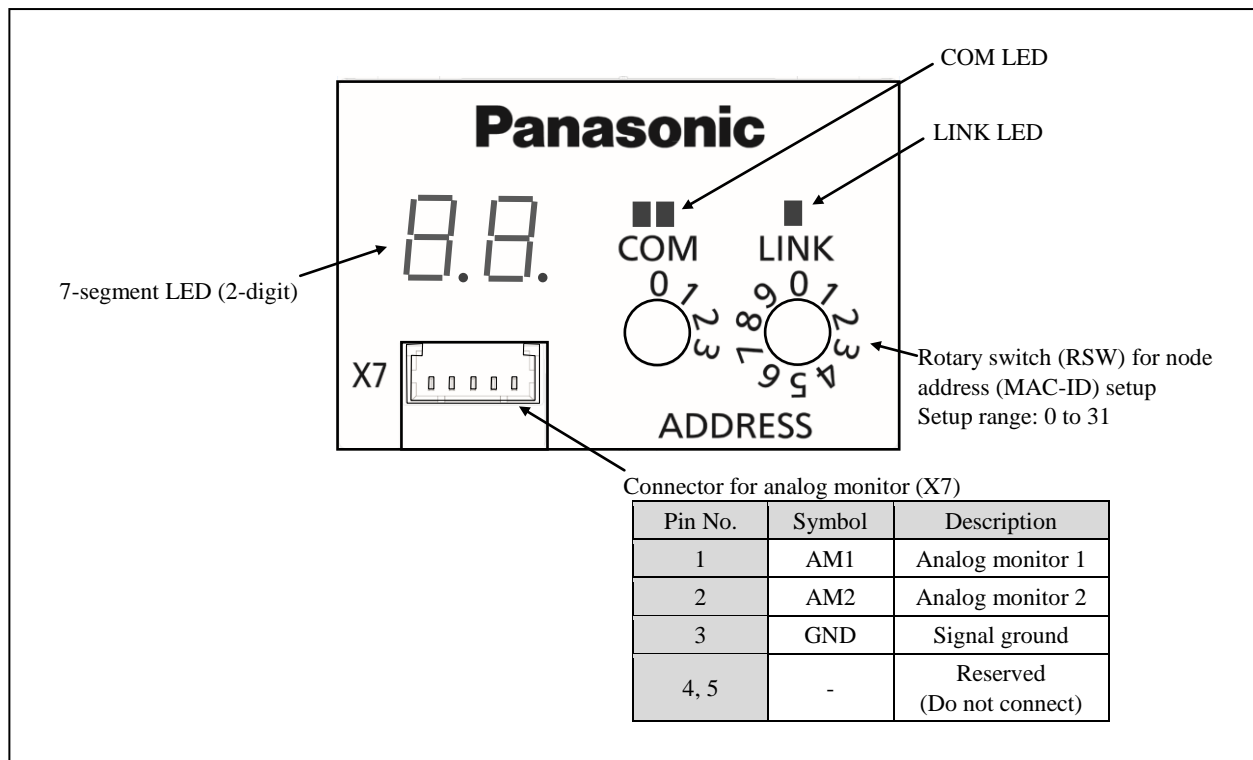

- Set the node address (MAC-ID) in a decimal number: high order digit on MSD rotary switch and low order on LSD switch.
Example: When MAC-ID is 13, MSD = 1, LSD = 3.
- Node address (MAC-ID) set with the rotary switch will be loaded once when the control power is turned on. Therefore, a change made after the power up will not be reflected to the control but will become active upon the next power up.
- Do not change the value of the rotary switch in power on to avoid a trouble.
- Setup range of the node address (MAC-ID) is 0 to 31.
If the setup value exceeds 31, Err 82.0 “COM invalid node-address protection” will be occurred.
- The host controller (master), when transmitting, should specify the node address (MAC-ID) in Byte 0, bits 4-0 of the command. If the node address is different from the address specified by the servo drive, Err 86.0 “Cyclic data error protection 1” will occur.

2-5 Communication cycle/command updating cycle, control mode and data size setup

Designation	Description							
Communication cycle	<ul style="list-style-type: none"> The cycle at which command or response RTEX frame is transferred. The servo driver processes the command and response basically at this cycle. Exception: when the communication cycle is 0.0625 [ms] 							
Command updating cycle	<ul style="list-style-type: none"> The cycle at which the host controller will update the command. In response, the servo driver performs the following processes. <table border="1"> <tr> <td>Communication cycle 0.0625 ms</td> <td> <ul style="list-style-type: none"> Processes the command and response with a period of 0.125 ms. Set the command updating cycle to 0.125 ms. </td> </tr> <tr> <td rowspan="2">Other communication cycles</td> <td>CP</td> <td> <ul style="list-style-type: none"> Calculates the changes in command position (CPOS) during command updating period and generates the movement command. If the command updating cycle on the servo driver is different from that on the host controller, operation error will occur. Processes commands and responses at a position other than the command position during communication cycle. </td> </tr> <tr> <td>PP/CV/CT</td> <td> <ul style="list-style-type: none"> Processes commands and responses at the communication cycle, regardless of the command updating cycle. </td> </tr> </table> 	Communication cycle 0.0625 ms	<ul style="list-style-type: none"> Processes the command and response with a period of 0.125 ms. Set the command updating cycle to 0.125 ms. 	Other communication cycles	CP	<ul style="list-style-type: none"> Calculates the changes in command position (CPOS) during command updating period and generates the movement command. If the command updating cycle on the servo driver is different from that on the host controller, operation error will occur. Processes commands and responses at a position other than the command position during communication cycle. 	PP/CV/CT	<ul style="list-style-type: none"> Processes commands and responses at the communication cycle, regardless of the command updating cycle.
Communication cycle 0.0625 ms	<ul style="list-style-type: none"> Processes the command and response with a period of 0.125 ms. Set the command updating cycle to 0.125 ms. 							
Other communication cycles	CP	<ul style="list-style-type: none"> Calculates the changes in command position (CPOS) during command updating period and generates the movement command. If the command updating cycle on the servo driver is different from that on the host controller, operation error will occur. Processes commands and responses at a position other than the command position during communication cycle. 						
	PP/CV/CT	<ul style="list-style-type: none"> Processes commands and responses at the communication cycle, regardless of the command updating cycle. 						

Control mode	Abbreviation	Command code	Description
NOP	NOP	0□h	Use this mode when transmitting temporary invalid data immediately after establishment of the network. Never use this mode for any other purpose. Upon receiving this command, perform the control based on the previously received command.
Profile position mode	PP	1□h	Use this mode when operating by specifying target position, target speed and target acceleration/deceleration (parameter) and by generating position command in the servo driver.
Cyclic position mode	CP	2□h	Use this mode when operating by generating position command in the host controller and by updating (transmitting) the command position at the command updating cycle.
Cyclic velocity mode	CV	3□h	Use this mode when operating by generating velocity command in the host controller and by updating (transmitting) the command velocity at the communication cycle.
Cyclic torque mode	CT	4□h	Use this mode when operating by generating torque command in the host controller and by updating (transmitting) the command torque at the communication cycle.

2-5-1 Mode reference table

MINAS-A6N is compatible with the communication cycle, command updating cycle, control mode and data size shown in the table below.

Responds only to position control (PP, CP) under full-closed control. Switching over to CV or CT is not possible.

Note:

- Communication cycle and command update cycle are different from the part MINAS-A5N series.
- In case of communication cycle 0.25 [ms] or less, the electronic gear ratio supports only 1/1.
- The accuracy of communication cycle of a host controller shall be designed within $\pm 0.05\%$.
- Full-closed control cannot be used in [A6NE].
- In semi-closed control, external scale position information monitor function cannot be used in [A6NE].

(1) 16 byte mode

- ⊙: Compatible with both semi- and full- closed control; ○: Compatible only with semi-closed control;
 -: Not compatible

Communication period (ms)	Command update period (ms)																							
	0.125				0.250				0.5				1.0				2.0				4.0			
	PP	CP	CV	CT	PP	CP	CV	CT	PP	CP	CV	CT	PP	CP	CV	CT	PP	CP	CV	CT	PP	CP	CV	CT
0.0625	-	○	○	○	-	-	-	-	-	-	-	-	-	-	-	-	-	-	-	-	-	-	-	-
0.125	-	○	○	○	-	○	○	○	-	-	-	-	-	-	-	-	-	-	-	-	-	-	-	-
0.250	/				-	○	○	○	-	○	○	○	-	-	-	-	-	-	-	-	-	-	-	-
0.5	/				/				⊙	⊙	○	○	⊙	⊙	○	○	-	-	-	-	-	-	-	-
1.0	/				/				/				⊙	⊙	○	○	⊙	⊙	○	○	-	-	-	-
2.0	/				/				/				/				⊙	⊙	○	○	⊙	⊙	○	○

* In case bit 4 of Pr7.22 “External scale position information monitor function under semi-closed control” is set to valid, it will not respond to communication cycle of 0.250 [ms] or less. (Excluding NOP)

(2) 32 byte mode

- ⊙: Compatible with both semi- and full- closed control; ○: Compatible only with semi-closed control;
 -: Not compatible

Communication period (ms)	Command update period (ms)																							
	0.125				0.250				0.5				1.0				2.0				4.0			
	PP	CP	CV	CT	PP	CP	CV	CT	PP	CP	CV	CT	PP	CP	CV	CT	PP	CP	CV	CT	PP	CP	CV	CT
0.0625	-	-	-	-	-	-	-	-	-	-	-	-	-	-	-	-	-	-	-	-	-	-	-	-
0.125	-	-	-	-	-	-	-	-	-	-	-	-	-	-	-	-	-	-	-	-	-	-	-	-
0.250	/				-	-	-	-	-	-	-	-	-	-	-	-	-	-	-	-	-	-	-	-
0.5	/				/				⊙	⊙	○	○	⊙	⊙	○	○	-	-	-	-	-	-	-	-
1.0	/				/				/				⊙	⊙	○	○	⊙	⊙	○	○	-	-	-	-
2.0	/				/				/				/				⊙	⊙	○	○	⊙	⊙	○	○

2-5-2 Related Parameter

Class	No.	Attribute	Title	Setup range	Unit	Function
0	01	R	Control mode setup	0-6	-	You can set up the control mode to be used. 0: semi-closed control Selectable between position (PP/CP), velocity (CV) and torque (CT) controls 6: Full-closed control Position control (PP/CP) only Others (can be set only by the manufacturer and not by the user)
7	20	R	RTEX communication cycle setup	1-12	-	Set up the RTEX communication cycle. -1: Enable the setup by Pr7.91 3: 0.5 (ms) 6: 1.0 (ms) Others (can be set only by the manufacturer and not by the user)
7	21	R	RTEX command updating cycle setup	1-2	-	Set up the ratio of RTEX communication cycle to command updating cycle. Setting = command updating cycle to communication cycle ratio 1: 1 (time) 2: 2 (times)
7	22	R	RTEX function extended setup 1	-32768-32767	-	[bit 0] specifies the data size of RTEX communication. 0: 16-byte mode 1: 32-byte mode [bit 1] specifies the inter-axis sync mode when 2 or more axes are used with TMG_CNT. Set this parameter to 0 when not using TMG_CNT. 0: Interaxis semi-synchronous mode 1: Interaxis full-synchronous mode ▪ For details, refer to 4-2-1-1. [bit4] External scale position information monitoring function under semi-closed control setting: 0 : Invalid 1 : Valid ▪ Under full-closed control, external scale position information can be monitored regardless of the setting of this bit.
7	91	R	RTEX communication cycle expansion setting	0-2000000	ns	Set the communication cycle of RTEX communication in a unit of ns. This parameter is enabled only when Pr7.20 is -1. *Do not set other value than 0.0625, 0.125, 0.250, 0.5, 1, and 2 [ms].

Note:

Make sure to set the same cycle as the upper equipment for the RTEX communication cycle (Pr7.20, Pr7.91) and RTEX command updating cycle (Pr7.21).
Also, make sure to set the same setting as the upper equipment for the extended RTEX function (Pr7.22).
Otherwise, the operation cannot be guaranteed.

■ RTEX communication setting by the setup support software

You can easily set RTEX communication parameters using “RTEX communication setting function *1)” of the setup support software.

In the communication status monitoring screen of the “RTEX communication setting function”, you can monitor the measurement results of the RTEX communication data sent from the host device in the real cycles. This function allows you to check the cycle fluctuation of the communication data sent from the host device. So use this function for the analysis of communication establishment and communication errors. *2)

*1) It can be used in combination with PANATERM (6.0.1.5 or later) and an amplifier of function extended edition 3 or a later version.

*2) The monitor values are the real-cycle representation of the measurement results of the RTEX communication data that the driver received from the host device. Use the values to check the communication intervals just for reference because they include internal clock errors of the driver.

2-5-3 Example of mode setup

Communication period of 0.5 ms, command updating period 1.0 ms, semi-closed control, 16-byte mode and interaxis semi-synchronous mode

- Pr.0.01 = 0 (Semi-closed control)
- Pr.7.20 = 3 (Communication cycle 0.5 ms)
- Pr.7.21 = 2 (Command updating cycle 1.0 ms = 0.5 ms × 2)
- Pr.7.22 = 0 (16-byte mode and interaxis semi-synchronous mode)

* When Pr7.20 is not "-1", Pr7.91 is not available.

In this example setting, CP/CV/CT control mode selection is necessary by specifying command code.

Note:

If the combination of Pr7.20 "RTEX communication cycle setup", Pr7.91 "RTEX communication cycle expansion setting", Pr7.21 "RTEX command updating cycle setup" and electronic gear ratio is are not suitable, Err93.5 "Parameter setting error protection 4" is generated.

2-6 COM LED, LINK LED and RTEX communication state

The table below shows display state of COM LED and LINK LED and RTEX communication status.

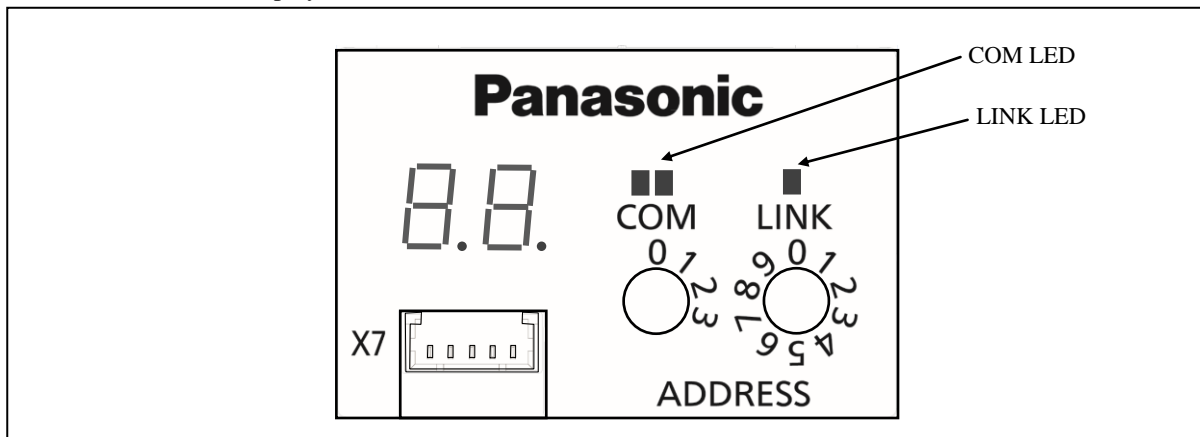

■ COM LED

State	Description				
	RTEX communication state	Pr.7.23 bit 4 = 0		Pr.7.23 bit 4 = 1	
		RTEX communication IC state	Communication and servo are Synced	RTEX communication IC state	Communication and servo are Synced
OFF	Not established	• INITIAL	Not dependent	• INITIAL	Not established
Flashing Green	Under configuring	• RING_CONFIG • READY		• RING_CONFIG • READY • RUNNING	Not established
Solid Green	Established	• RUNNING		• RUNNING	Established
Flashing Red	Clearable alarm relating to RTEX communication has occurred.				
Solid Red	Non-clearable alarm relating to RTEX communication has occurred.				

■ LINK LED

State	Description
OFF	Non-connecting (No power entry of transmitter node, or cable disconnection)
Solid Green	Proper connecting (“TX” of transmitter node and own “RX” is electrically connected)

- If RTEX communication related alarm occurs while non-RTEX alarm (e.g. Err. 16.0) has occurred, COM LED shows the new alarm by lighting or flashing in red as described above.
Note that the 7-seg LED still displays the non-RTEX related alarm.
- Upon power up or upon issuing of the reset command, LINK LED will blink once. This is normal because the LED is initialized by the servo driver.
- Lighting condition of COM LED can be changed by the setting of bit 4 of Pr.7.23 “RTEX function extended setup 2”.

3. Transmission Protocol of RTEX Communication Data

3-1 Transmission timing of data

- If the synchronization between the communication and servo is not established, the command receiving timing and response transmitting timing are unstable.
The timing diagram in this chapter shows established synchronization which can be verified through the logic output signal (extended portion) of the monitor command.
- Because the echo back of the Update_Counter is generated in the data exchanging process of the servo driver, the echo back (Update_Counter_Echo) is immediately returned unless a communication error occurs.
- In contrast, the echo back (Command_Code_Echo) in response to the command code is not immediately returned because it is generated in command/response process. Relationship between Update_Counter and command code may not be the same for transmitted data and received data.
- If the control mode is switched to a different control mode when the communication cycle is 0.0625 ms or 0.125 ms, the response timing of the command code echo back is different from the response timing of internal data e.g. position deviation which depends on the control mode. For details, refer to timing diagram in 3-1-3 and 3-1-4.
- If the command is not correctly received due to problem caused by command code or argument, the command error bit (CMD_Error or Sub_CMD_Err) is set to 1 and returned. When the servo driver correctly receives the command, the command error bit is set to 0.
For secure command transfer, hold the command code value until the echo back is received.
- Check the echo back of command (echo data such as Command_Code_Echo, Type_Code_Echo and Index_Echo) to confirm whether the correct command is surely transferred.
Operated without checking echo back, it may be an unintended operation.
- When communication cycle is 250 μ s or less, set Update_Counter with the same value and update with the command updating cycle for all axes.
- Set operation commands (position, speed and torque commands) after a lapse of 100 ms or more after Servo-ON command.
Refer to technical reference Functional Specification “Section 9-2” for the timing chart.

3-1-1 Transmission timing of communication period 0.0625 ms/command updating period 0.125 ms

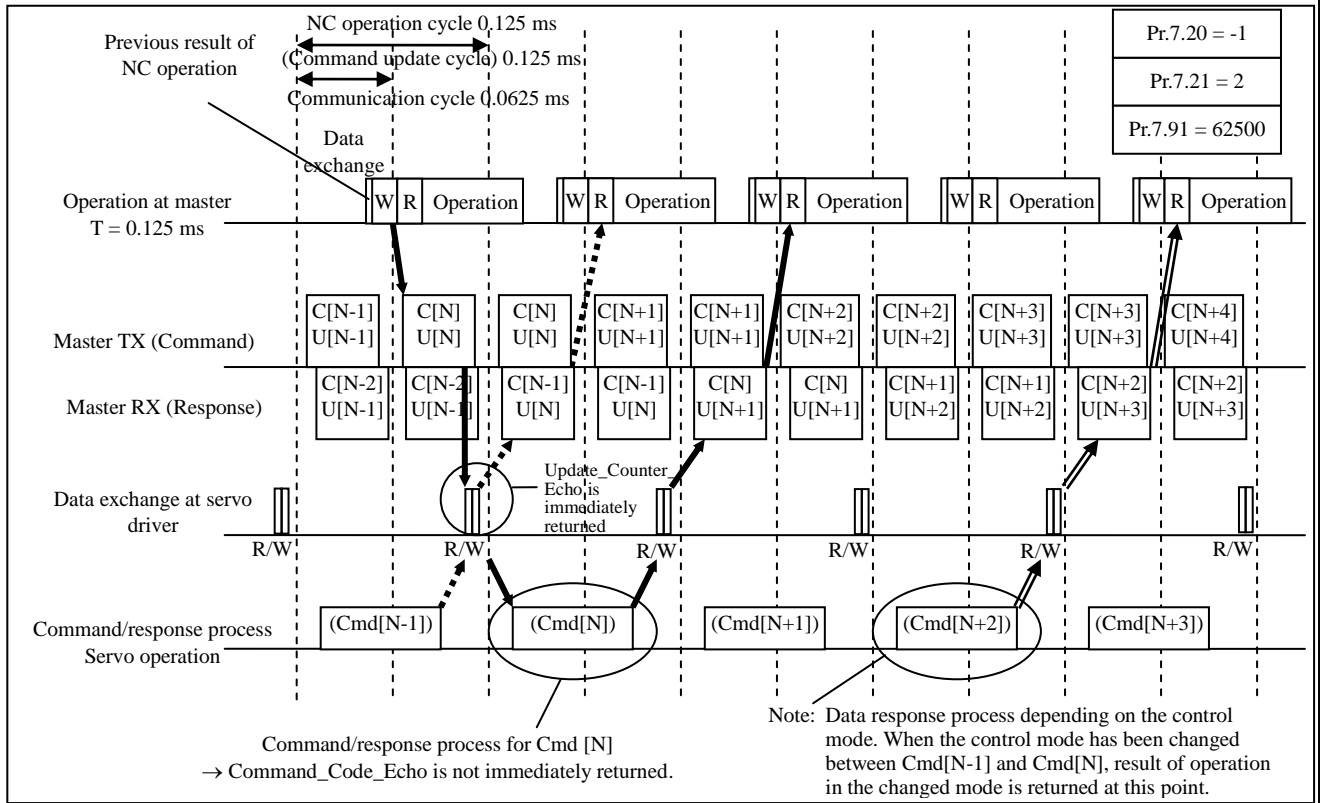

3-1-2 Transmission timing of communication cycle 0.125 ms/command updating cycle 0.125 ms

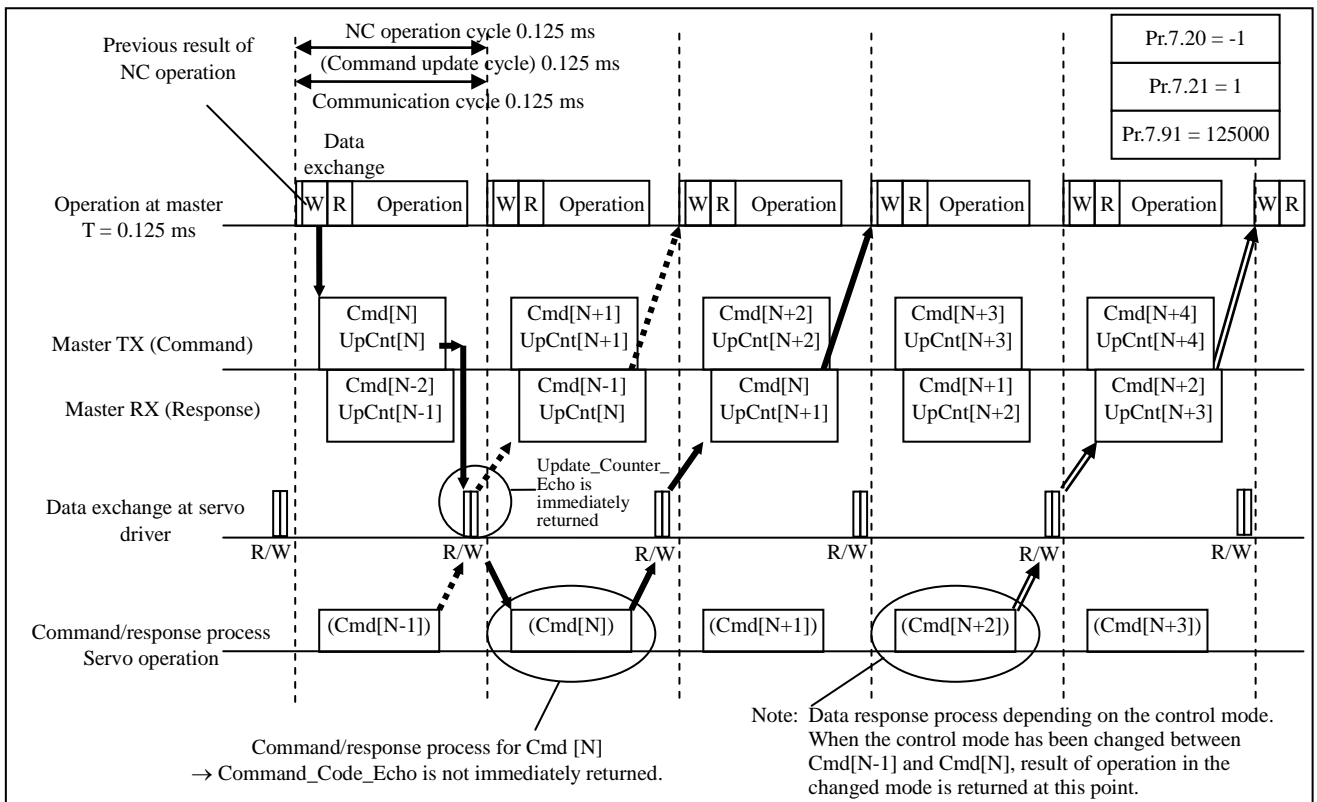

3-1-3 Transmission timing of communication cycle 0.125 ms/command updating cycle 0.250 ms

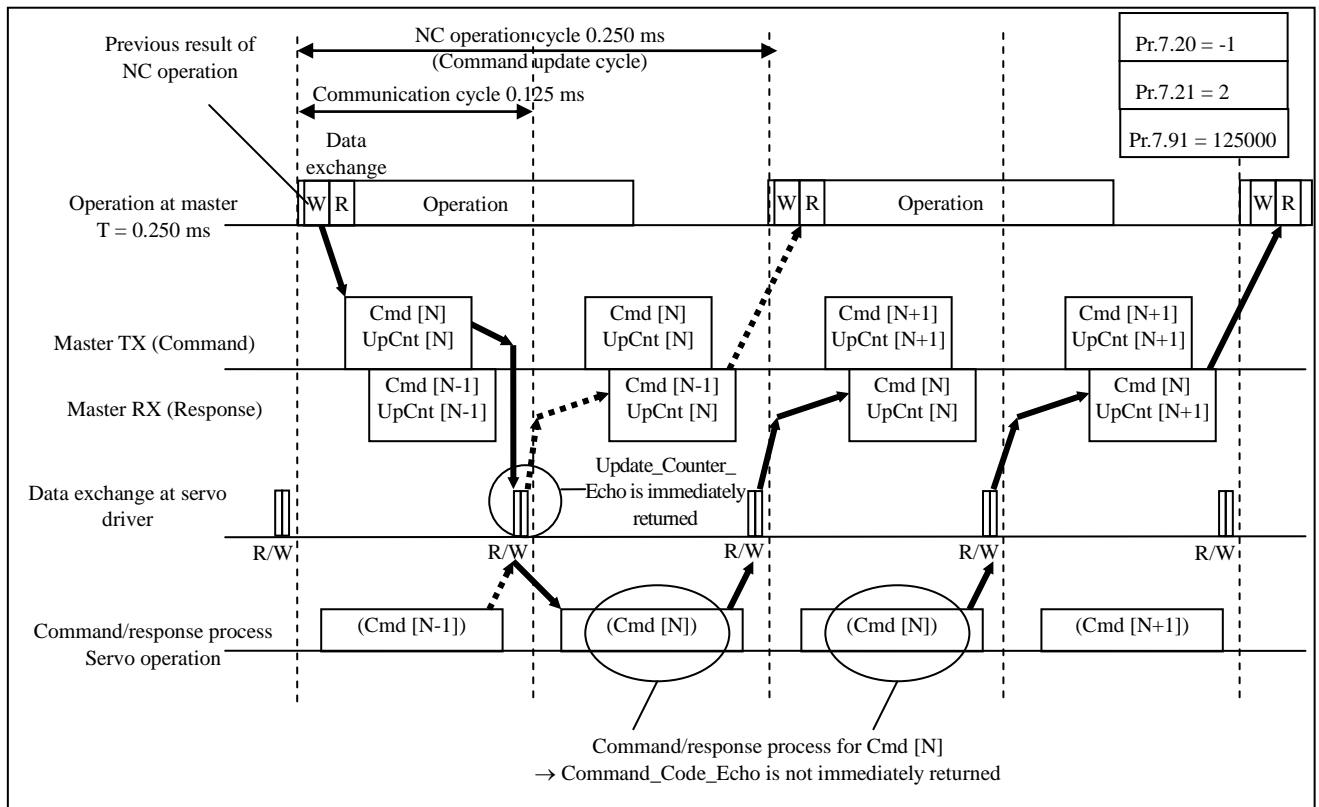

3-1-4 Transmission timing of communication period 0.250 ms/command updating period 0.250 ms

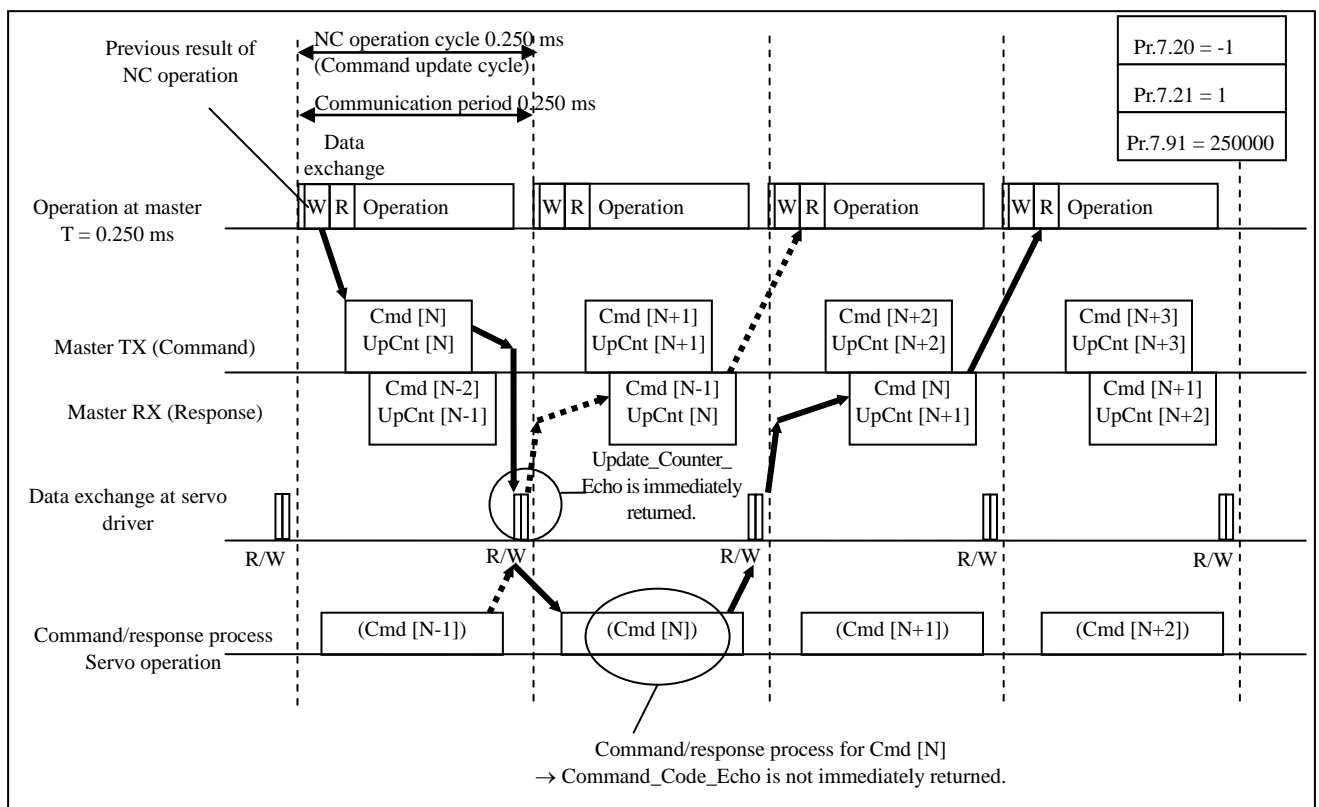

3-1-5 Transmission timing of communication cycle 0.250 ms/command updating cycle 0.5 ms

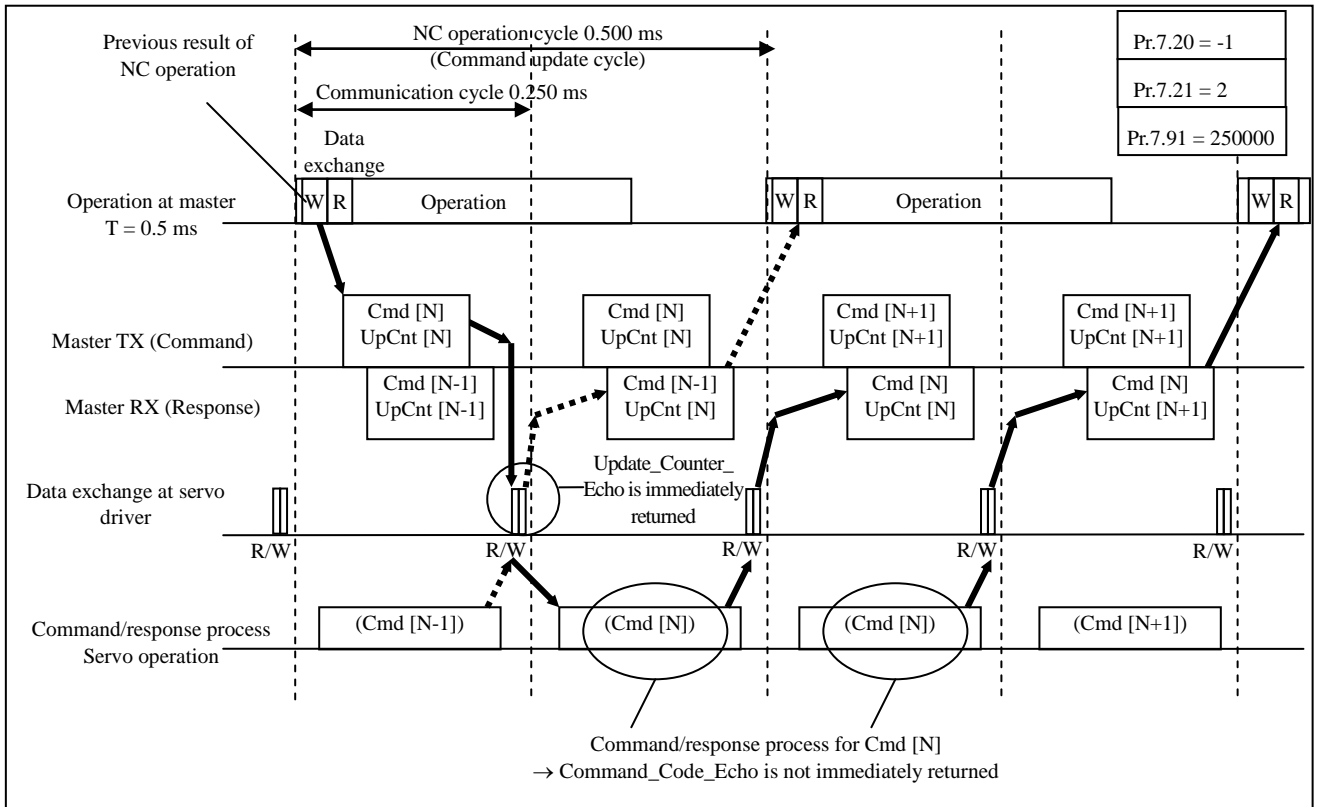

3-1-6 Transmission timing of communication period 0.5 ms/command updating period 0.5 ms

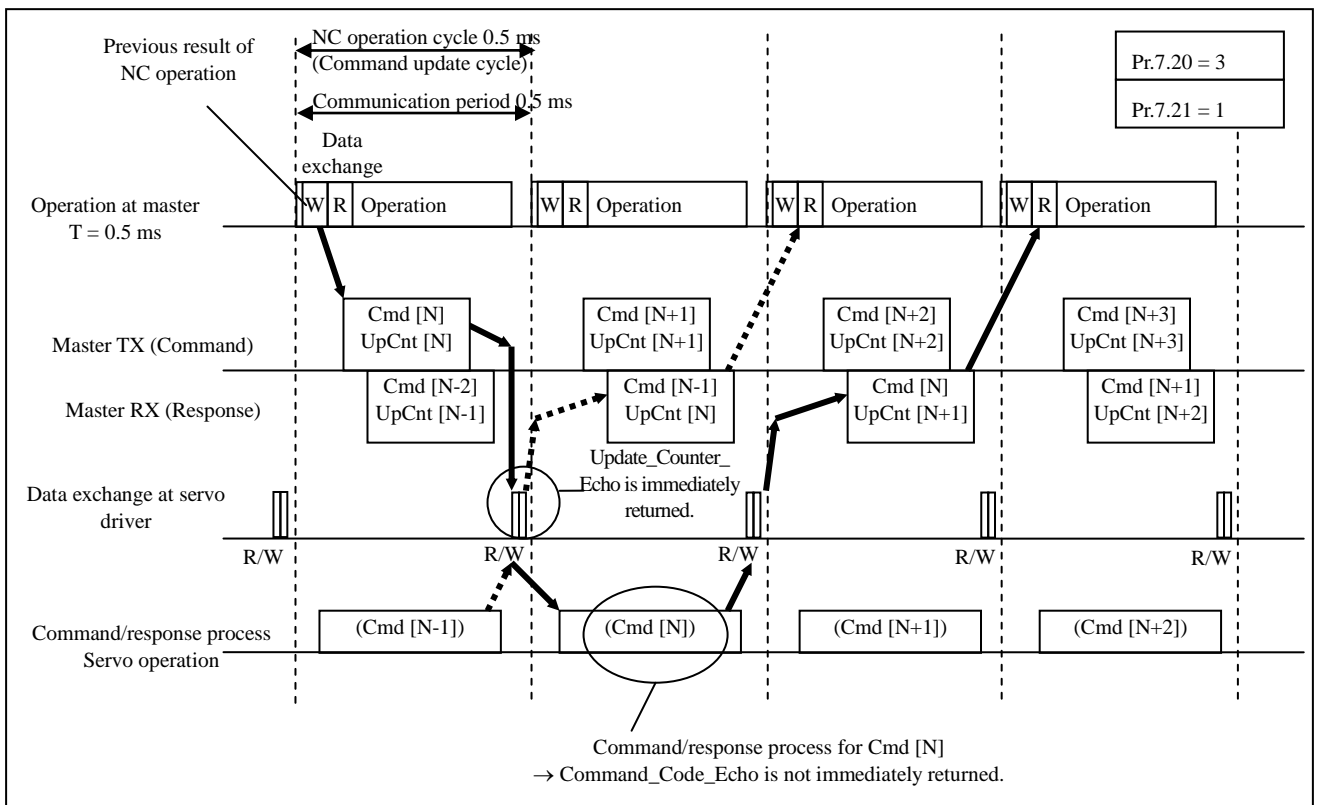

3-1-7 Transmission timing of communication cycle 0.5 ms/command updating cycle 1.0 ms

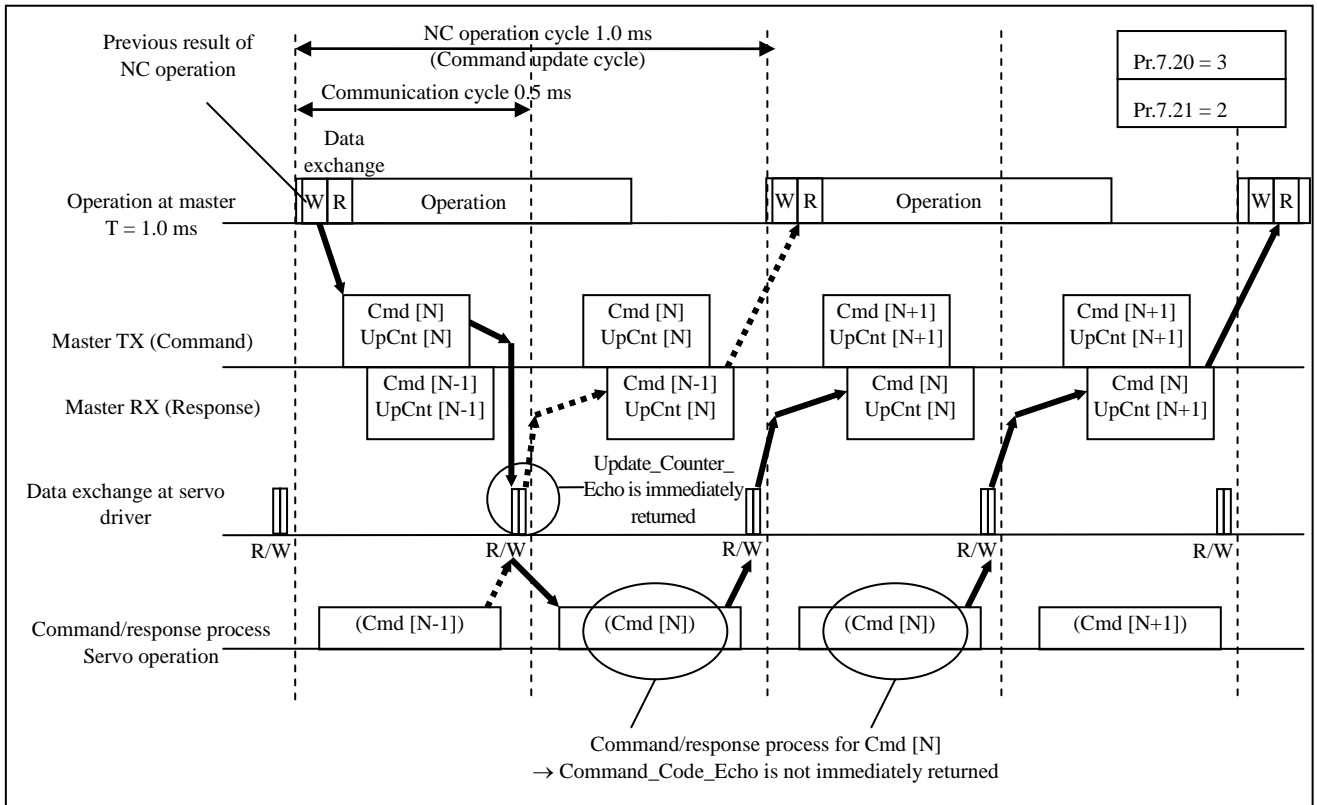

3-1-8 Transmission timing of communication period 1.0 ms/command updating period 1.0 ms

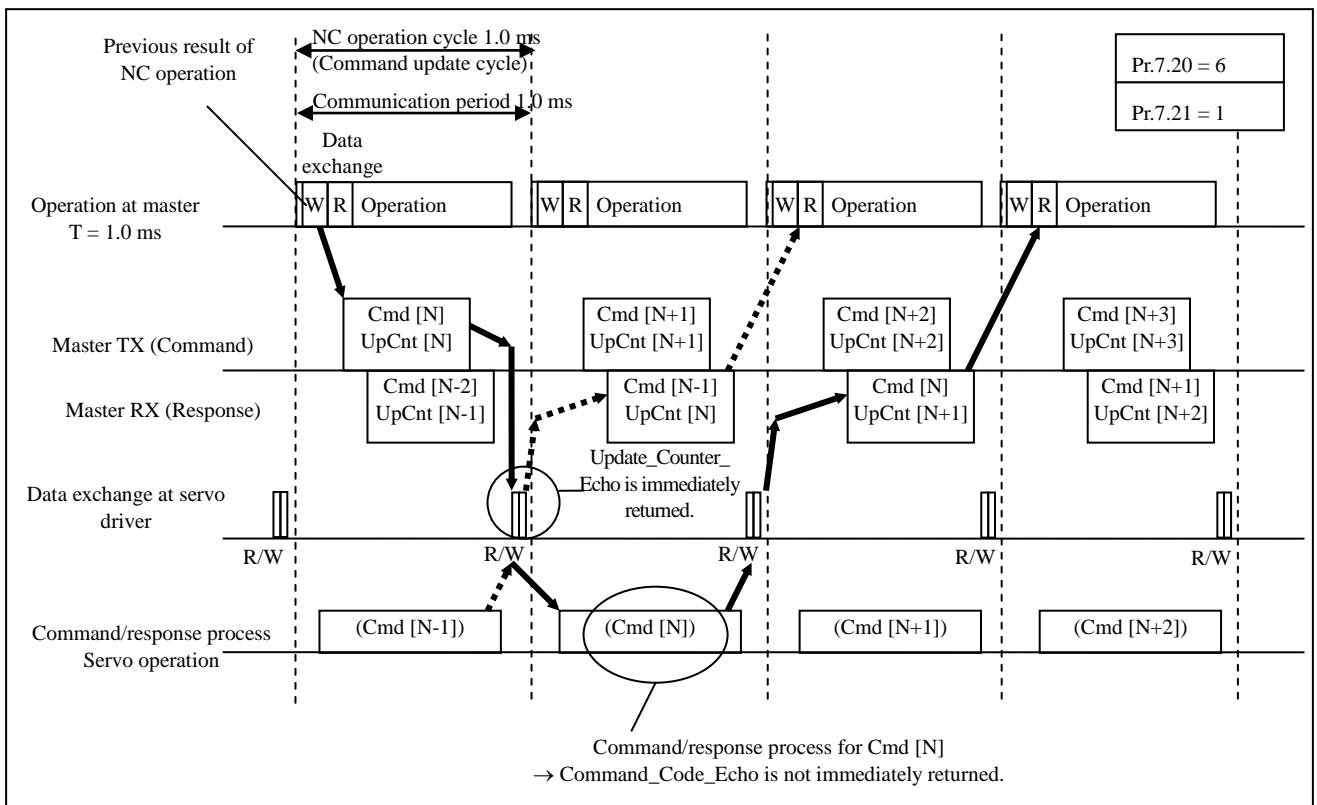

3-1-9 Transmission timing of communication cycle 1.0 ms/command updating cycle 2.0 ms

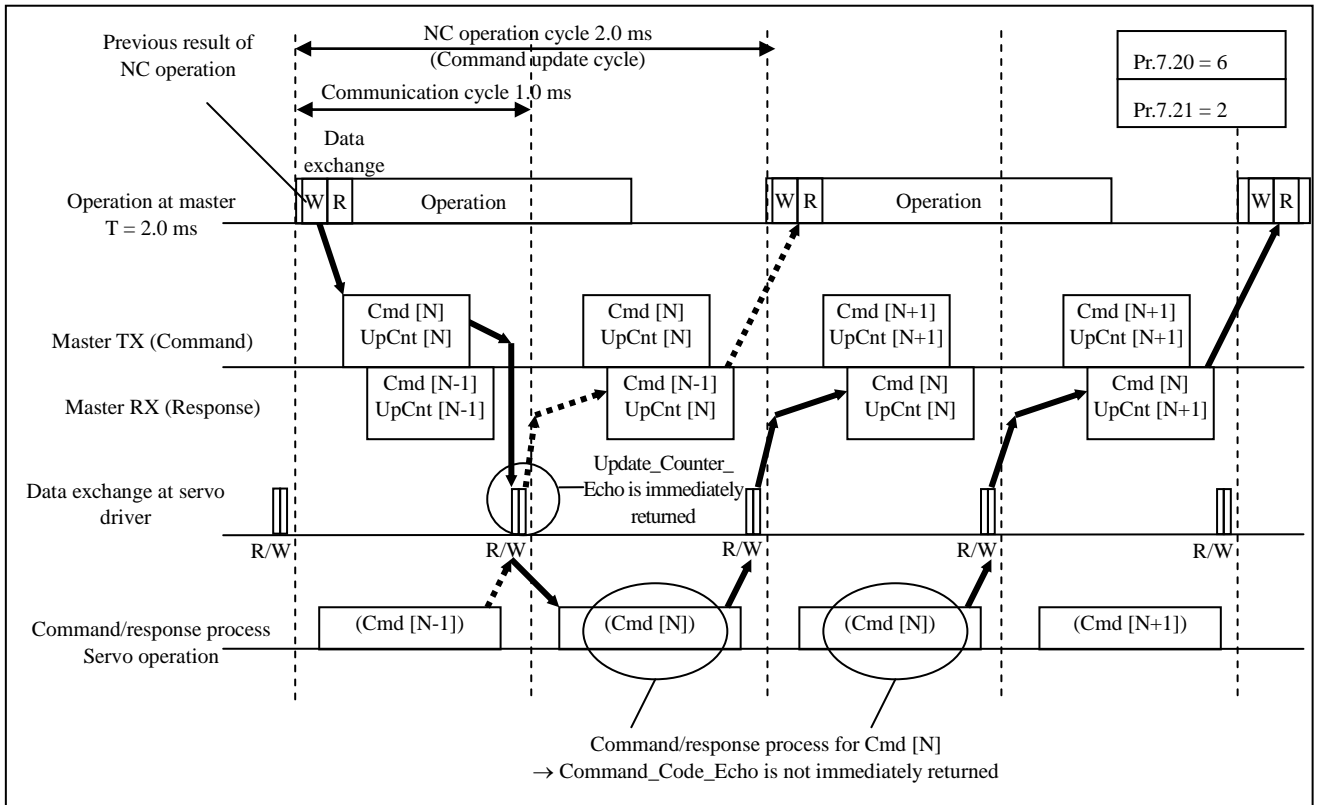

3-1-10 Transmission timing of communication period 2.0 ms/command updating period 2.0 ms

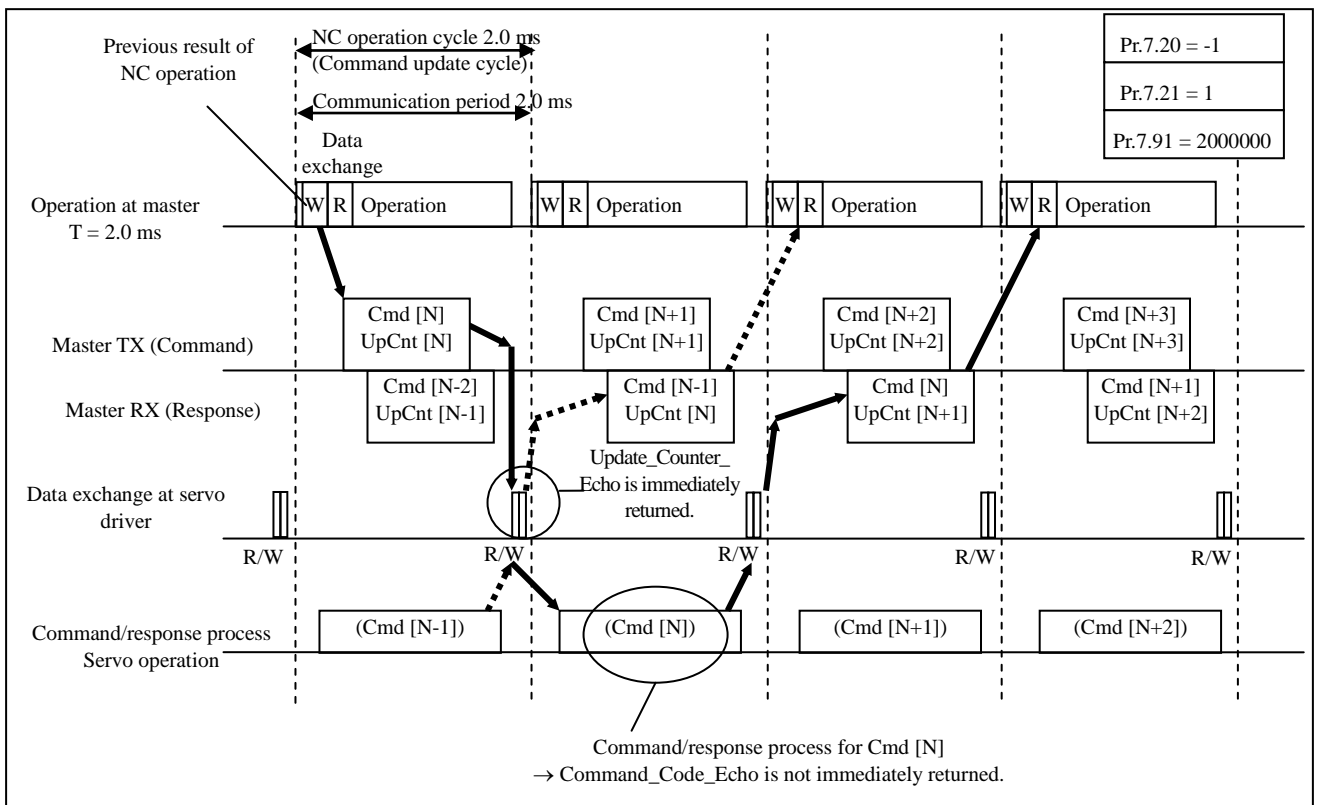

3-1-11 Transmission timing of communication cycle 2.0 ms/command updating cycle 4.0 ms

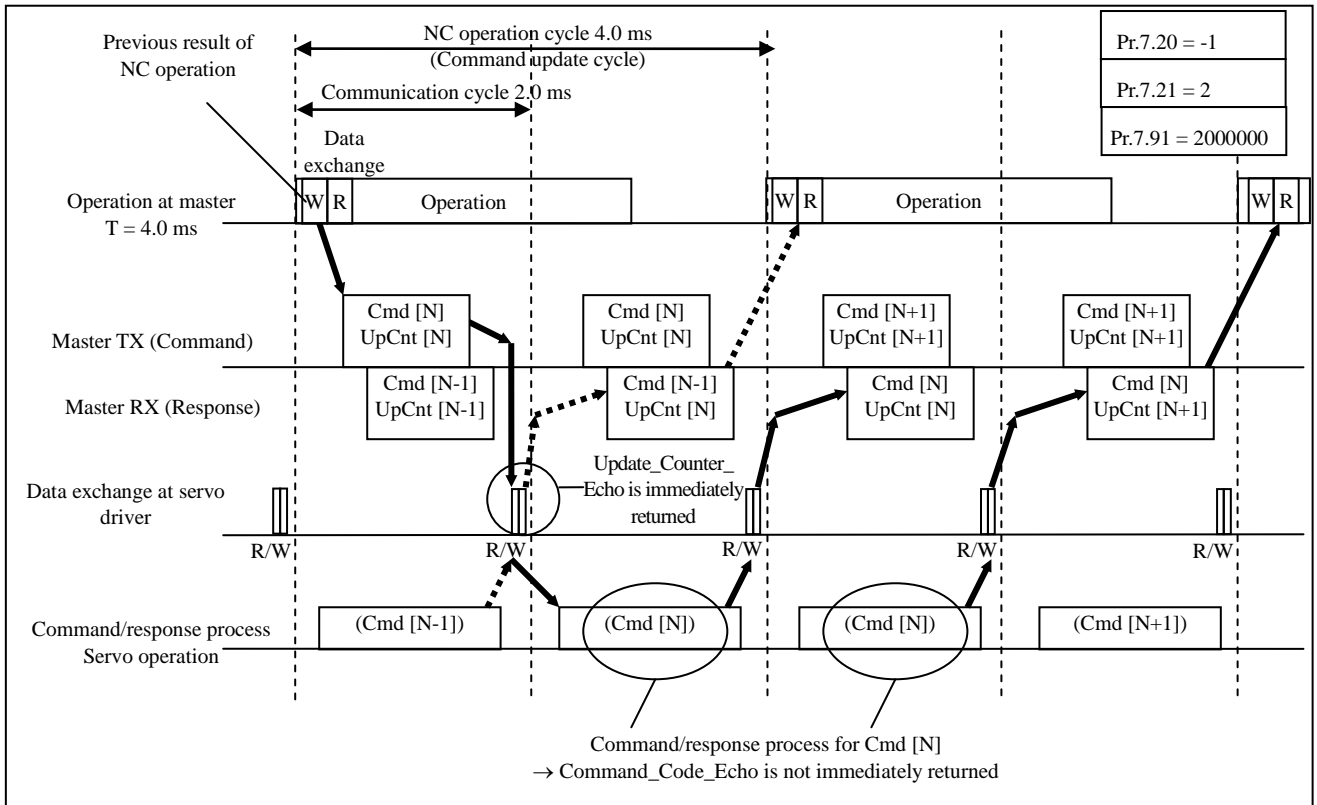

3-2 Transmission of cyclic data

3-2-1 Cyclic transmission area

Use bytes 2 to 7 in command/response data block or bytes 24 to 31 in the 32-byte mode, as cyclic transmission area for real-time data such as command position and feedforward data.

Use bytes 12 to 15 (Command_Data3) in command data block as cyclic transmission area by using Pr.7.35 “RTEX command setting 1”. For details, refer to 7-7.

Use bytes 8 to 15 (Reponse_Data2/3) in response data block, or bytes 20 to 23 (Sub_Response_Data1) in the 32-byte mode, as cyclic transmission area by using Pr.7.30 to Pr.7.32 “RTEX monitor select 2/3/4”. For details, refer to 4-3-1.

There is no special transmission procedure for the cyclic command area data. The servo driver will reflect the received cyclic command data in the control at once, and will return the latest value of the cyclic response data.

■ Main command: Common to 16 byte and 32 byte mode

	Byte	Command								Byte	Response									
		bit7	6	5	4	3	2	1	0		bit7	6	5	4	3	2	1	0		
Cyclic	0	C (0)	Update_Counter		MAC-ID						0	R (1)	Update_Counter _Echo		Actual MAC-ID					
	1	TMG_ CNT	Command_Code								1	CMD_ Error	Command_Code_Echo							
	2	Control_Bits								2	Status_Flags									
	3									3										
	4									4										
	5	Command_Data1								5	Response_Data1									
	6									6										
Non-Cyclic	7									7										
	8	Command_Data2								8	Response_Data2									
	9									9										
	10									10										
	11									11										
	12	Command_Data3								12	Response_Data3									
	13									13										
14									14											
15									15											

■ Sub-command: Only for 32 byte mode

	Byte	Command								Byte	Response							
		bit7	6	5	4	3	2	1	0		bit7	6	5	4	3	2	1	0
Non-cyclic	16	Sub_ Chk	0	0	0	Sub_Command_Code				16	Sub_ CMD_ Err	Sub_ ERR	Sub_ WNG	Sub_ Busy	Sub_Command_Code_Echo			
	17	Sub_Type_Code								17	Sub_Type_Code_Echo							
	18	Sub_Index								18	Sub_Index_Echo							
	19									19								
	20	Sub_Command_Data1								20	Sub_Response_Data1							
	21									21								
Cyclic	22									22								
	23									23								
	24	Sub_Command_Data2								24	Sub_Response_Data2							
	25									25								
	26									26								
	27	Sub_Command_Data3								27	Sub_Response_Data3							
28									28									
29									29									
30									30									
31									31									

3-3 Transmission of Non-Cyclic Data

3-3-1 Non-cyclic transmission area

Use bytes 8 to 15 in Command/Response Data Block and bytes 17 to 23 in 32-byte mode as Non-cyclic transmission area for event-driven data such as parameter setup.

■ Main command: Common to 16 byte and 32 byte mode

	Byte	Command								Byte	Response							
		bit7	6	5	4	3	2	1	0		bit7	6	5	4	3	2	1	0
Cyclic	0	C (0)	Update_Counter		MAC-ID				0	R (1)	Update_Counter_Echo		Actual MAC-ID					
	1	TMG_CNT	Command_Code						1	CMD_Error	Command_Code_Echo							
	2	Control_Bits						2	Status_Flags									
	3																	
	4	Command_Data1						4	Response_Data1									
	5																	
	6																	
7																		
Non-cyclic	8	Command_Data2						8	Response_Data2									
	9																	
	10																	
	11	Command_Data3						11	Response_Data3									
	12																	
	13																	
	14																	
15																		

■ Sub-command: Only for 32 byte mode

	Byte	Command								Byte	Response							
		bit7	6	5	4	3	2	1	0		bit7	6	5	4	3	2	1	0
Non-cyclic	16	Sub_Chk	0	0	0	Sub_Command_Code			16	Sub_CMD_Err	Sub_ERR	Sub_WNG	Sub_Busy	Sub_Command_Code_Echo				
	17	Sub_Type_Code						17	Sub_Type_Code_Echo									
	18	Sub_Index						18	Sub_Index_Echo									
	19	Sub_Command_Data1						19	Sub_Response_Data1									
	20																	
	21																	
	22																	
23																		
Cyclic	24	Sub_Command_Data2						24	Sub_Response_Data2									
	25																	
	26																	
	27	Sub_Command_Data3						27	Sub_Response_Data3									
	28																	
	29																	
	30																	
31																		

3-3-2 Non-cyclic status flag

Byte 9, bits 7–4 in the response show the status of the non-cyclic command, if the command is not a normal one (□0h).

bit	Title	Description
7	ERR	Set to 1 when error occurs during process after reception of the command.
6	WNG	Set to 1 when the command is processed but with certain problem, e.g. written with restriction during parameter setting.
5	Reserved	Always return 0.
4	Busy	Kept at 1 while command is processed.

Byte 16, bits 6–4 in the response show the status of the sub-command in the 32-byte mode.

bit	Title	Description
6	Sub_ERR	Set to 1 when error occurs during process after reception of the command.
5	Sub_WNG	Set to 1 when the command is processed but with certain problem.
4	Sub_Busy	Kept at 1 while command is processed.

3-3-3 Non-cyclic command startup mode setting

To set start-up condition of the non-cyclic command, use Pr.7.23 “RTEX function extended setup 2”.

To make this condition compatible with MINAS-A4N, set bit 5 to 0.

Class	No.	Attribute	Title	Setup range	Unit	Function		
7	23	B	RTEX function extended setup 2	-32768 - 32767	—	[bit 5] sets non-cyclic command startup mode		
						Value	Function	See
						0	(MINAS-A4N compatible mode) Changing from standard command	3-3-4
1	(Extend mode) Upon changing command mode and command argument	3-3-5						

3-3-4 Startup of non-cyclic command (MINAS-A4N compatible mode)

When transmitting non-cyclic command (including sub-command) in the MINAS-A4N compatible mode (Pr.7.23, bit 5 = 0), follow the procedure described below.

- 1) Be sure to change the code from the standard command (e.g. 20h) to the desired non-cyclic command. (Set also Type_Code, Index, Command_Data3, etc., at the same time or beforehand.)
- 2) Hold the command until the normal echo-back is returned.
- 3) When normal echo-back is returned and Busy bit is 0, get the necessary data after checking ERR bit and WNG bit. After that, bring the command code back to the standard command (e.g. normal command: 20h).

* Check the echo back of command (echo data such as Command_Code_Echo, Type_Code_Echo and Index_Echo) to confirm whether the correct command is surely transferred.
Operated without checking echo back, it may be an unintended operation.

Standard command	Description
10h, 20h, 30h, 40h	<p>These are reference command for handshaking when transferring non-cyclic command.</p> <p>Normal command (□0h) serves as standard command.</p> <ul style="list-style-type: none"> ▪ If a sub-command, Sub_Command_Code = 0h is the standard command.

The change of command code is the trigger for executing the process. Only one process will be executed per one trigger.

■ Example: Operating procedure of non-cyclic command when changing parameter

When changing the multiple parameters continuously, it is necessary to bring the command code back to the standard command (e.g. normal command: 20h) every time a parameter is changed.

Note that the process will not be executed only with changing the parameter number.

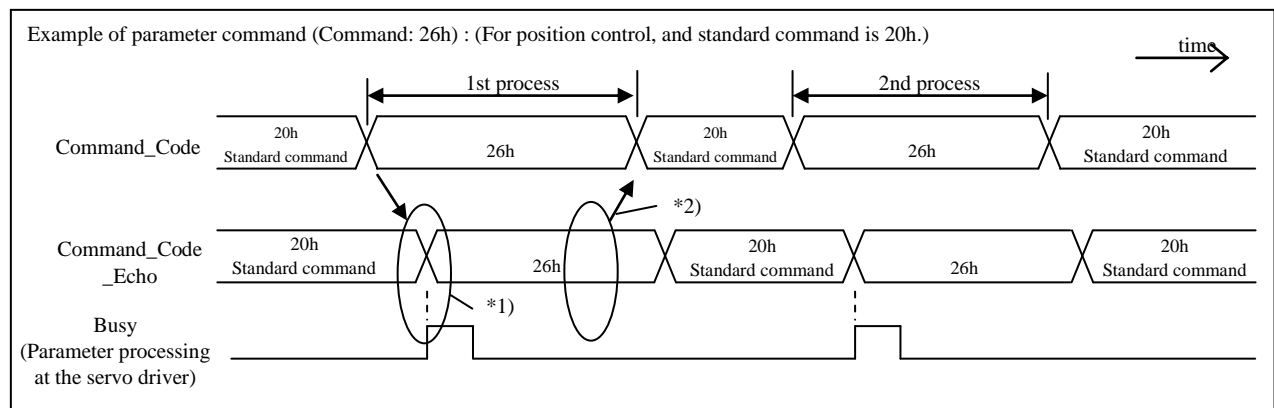

- *1) Parameter process will be executed in the servo driver at the transition from normal command (20h) to parameter command (26h).
 The servo driver will execute one process at transition of command code when it receives the same command during multiple communication cycles. (edge process)
- *2) Make sure that Busy is 0 and check for normal echo of command code (including Type_Code etc.), and then return to the normal command (20h).

3-3-4-1 Basic sequence of non-cyclic command

(When position control and the standard command is 20h)

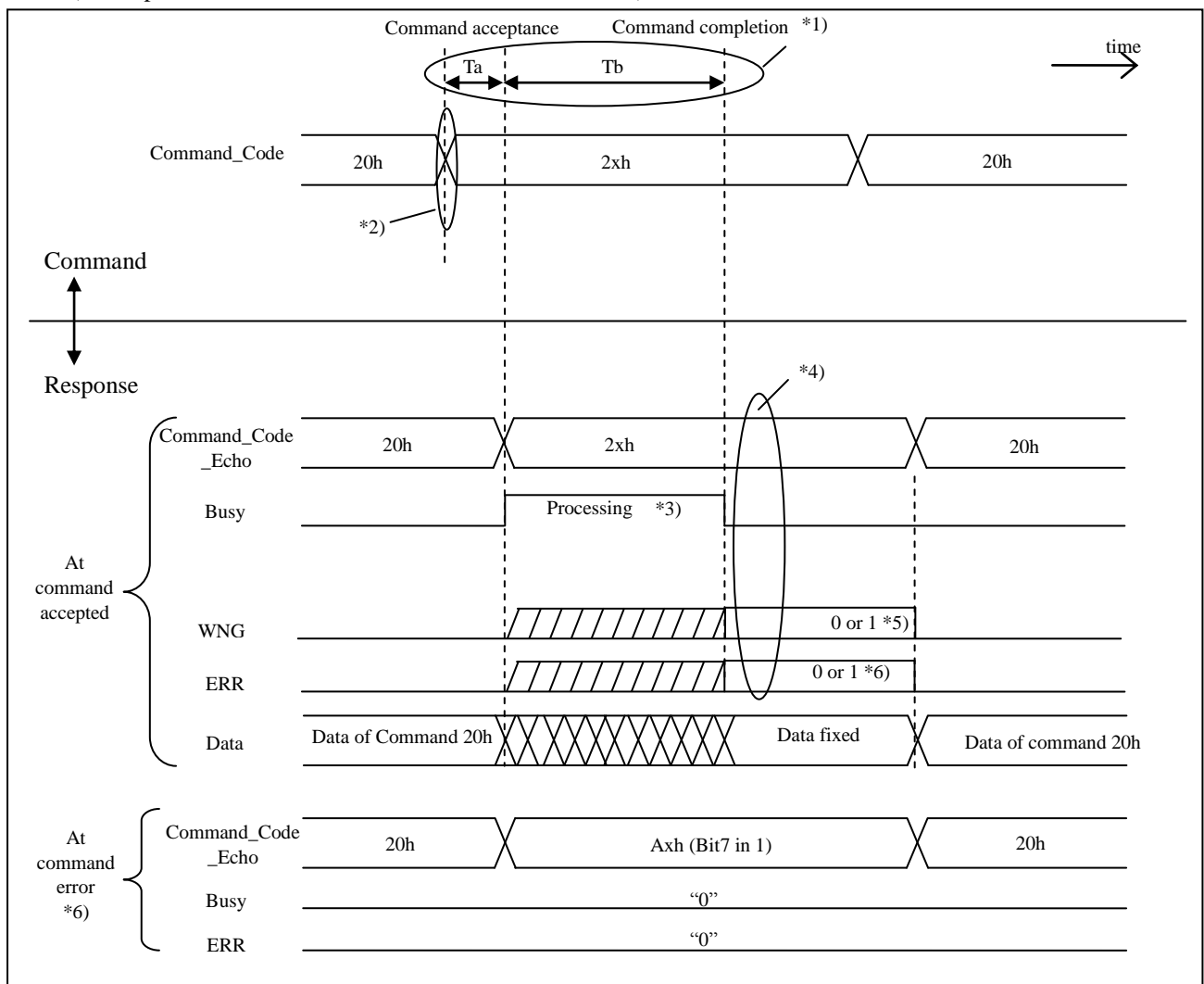

*1) Time of T_a and T_b depend on command.

In most reading processes, T_b will be 0 and Busy is not 1.

*2) Change of command code will be the trigger for executing the process.

*3) When you execute another non-cyclic command during processing (Busy is 1), command error (0101h) will occur.

*4) After confirming Busy is 0 (the process is completed), bring the command back to normal command (20h). The servo driver will continue to process even if command is returned to normal command during processing. (Note that part of homing process will be aborted.)

*5) WNG bit will be 1 when a problem occurs even though the process has been executed. (The parameter was set to the limited value that is different from the command value.)

*6) Command error shows whether the command could be accepted or not, and will be detected before executing the process.

Some kind of errors during processing will be shown in ERR bit instead of command error. An error might occur in some command (e.g. writing parameters to EEPROM) during processing. In such a case, retry the command after confirming that ERR bit becomes 1.

3-3-4-2 Read sequence of non-cyclic command

(When position control and the standard command is 20h)

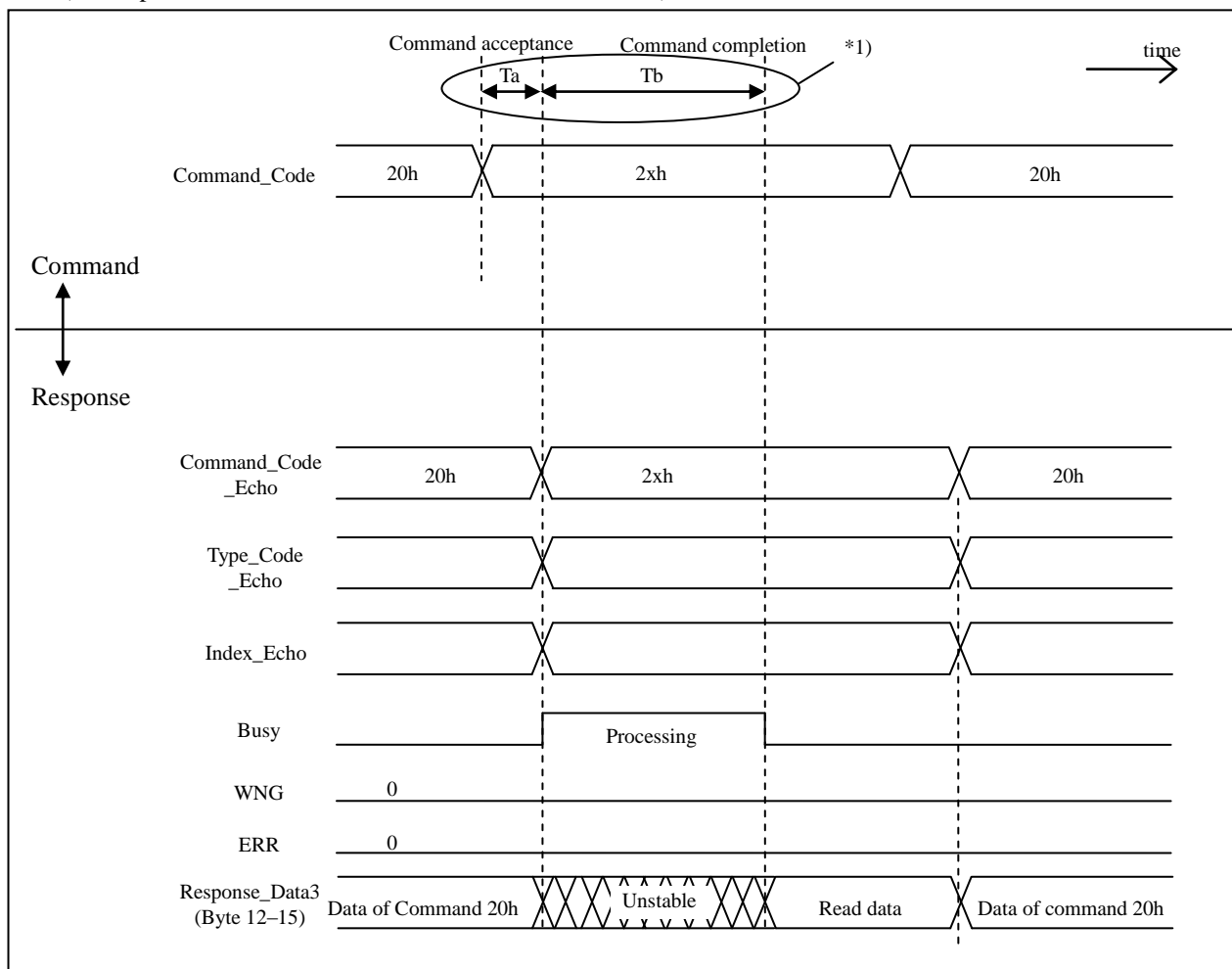

*1) Times of Ta and Tb depend on the command.
 In most reading cases, Busy will not be 1. (Tb is 0.)

3-3-4-3 Write sequence of non-cyclic command

(When position control and the standard command is 20h)

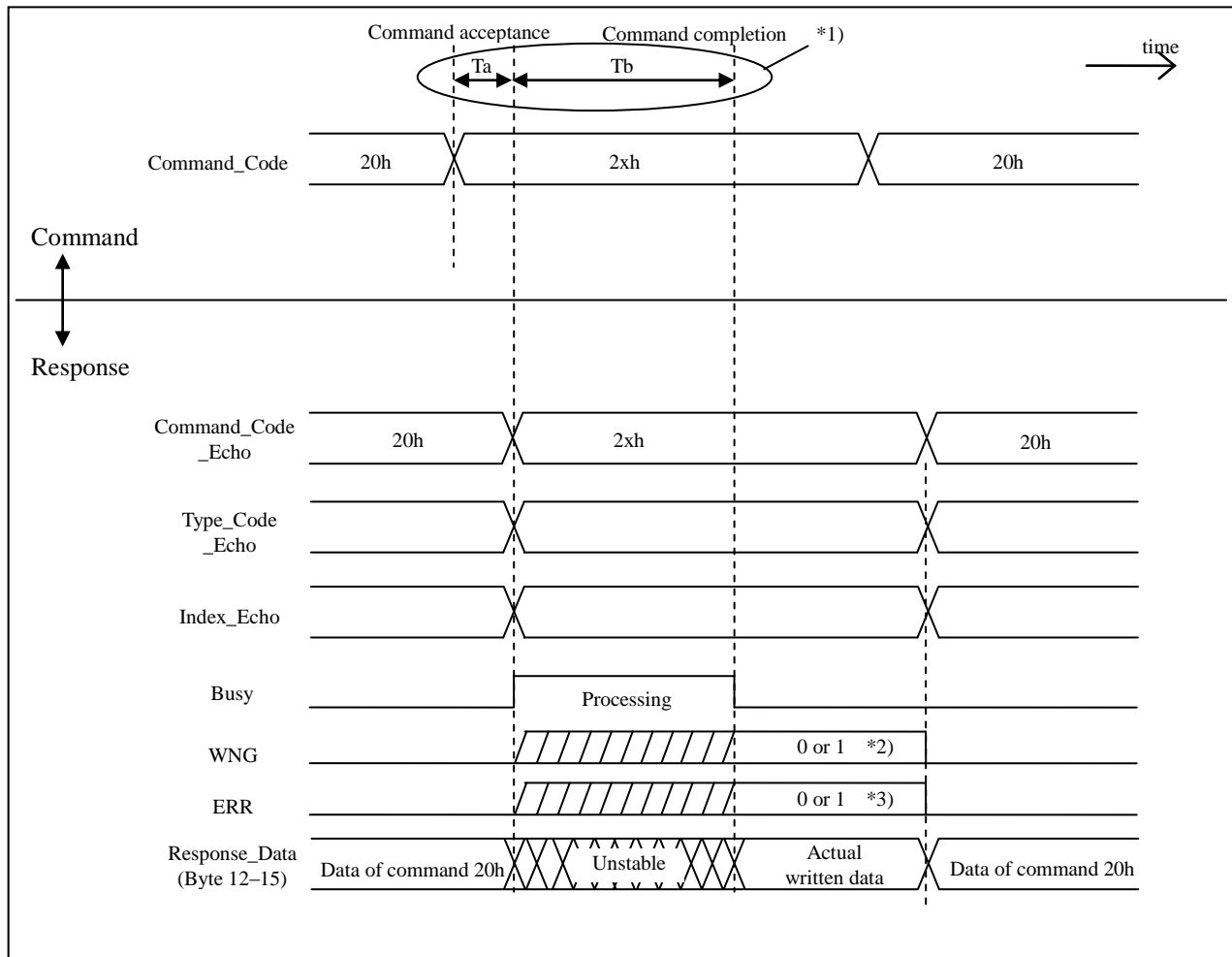

*1) Times of T_a and T_b depend on command.

*2) WNG bit will be 1 when a problem occurs even though the process has been executed.
(The parameter was set to the limited value that is different from the command value.)

*3) An error might occur in some command (e.g. writing parameters to EEPROM) during processing. In this case, ERR bit will be 1 and retry the command.

3-3-5 Startup of non-cyclic command (extend mode)

By setting non-cyclic command startup condition to the extend mode (Pr.7.23, bit 5 = 1), non-cyclic command can be started in the following condition as well as upon changing from the standard command. Because this condition is not applicable to certain commands, refer to individual command descriptions "Section 5,6".

1) Upon changing non-cyclic command code or sub-command code

2) Upon changing command argument (Command_Data2, Command_Data3)

Note: Not applied to Command_Data3 in feed forward data setting

Sub-command argument: Sub_Type_Code, Sub_Index or Sub_Command_Data1

■ Precautions

- Do not use this mode if two or more data which must be changed simultaneously cannot be updated at 1 cycle.
- Profile operation starts upon changing the command code from the normal command (10h) to profile command (17h).
Exception: When the target position or target speed is updated during profile operation, the servo drive will response to the change if the target position (TPOS) or target speed (TSPD) is changed while the command code 17h is maintained.

4. RTEX Communication Data Block

This chapter describes one or two data blocks (an axis worth of slave data: 16 or 32 bytes) allocated to the send/receive memory in the RTEX communication IC.

4-1 Transmission and reception memory in the RTEX communication IC

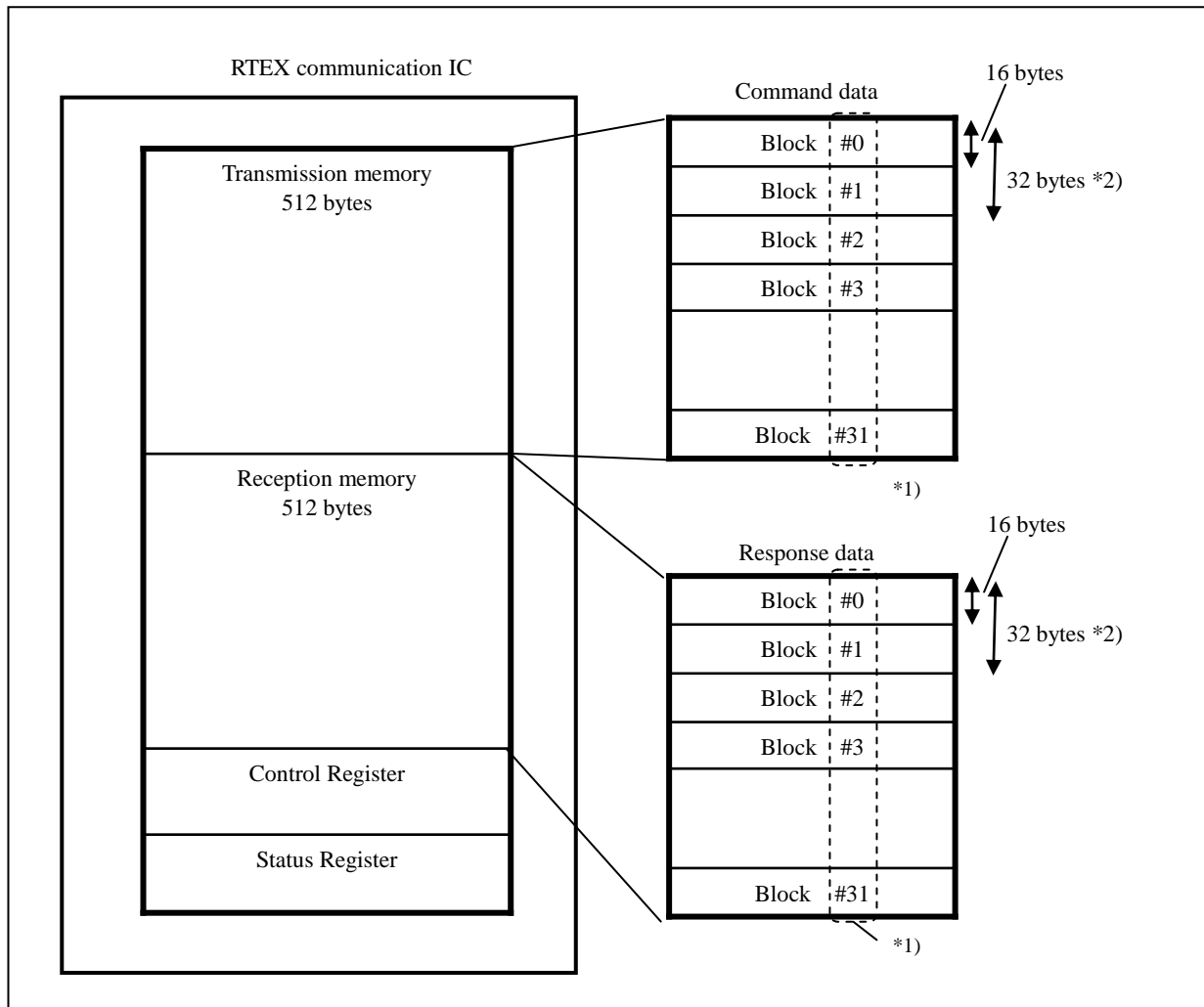

*1) Data block numbers, #0 to #31 represent the connecting order of the slaves.

Note that these are not the node addresses (MAC-ID).

*2) The slave set to 32-byte mode uses 2 consecutive 16-byte data blocks.

4-2 Command data block arrangement (16-byte/32-byte mode)

Command will be transmitted from the master (host controller) to slave (servo driver).

Byte	bit 7	bit 6	bit 5	bit 4	bit 3	bit 2	bit 1	bit 0
0	C/R(0)	Update_Counter		MAC-ID (0 to 31)				
1	TMG_CNT	Command_Code						
2	Servo_On	V_Full	0	Gain_SW	TL_SW	Homing_Ctrl	0	0
3	Hard_Stop	Smooth_Stop	Pause	0	SL_SW	0	EX-OUT2	EX-OUT1
4	Command_Data1							L
5								ML
6								MH
7								H
8	Command_Data2							L
9								ML
10								MH
11								H
12	Command_Data3							L
13								ML
14								MH
15								H

Notes: • Command code of byte 1 defines the contents from byte 4 to byte 15.

- Disposition of multiple byte data is little endian, which means that lower byte is first.
- Set the unused bit to 0.
- Of the commands from Byte2 to Byte15, only Byte2 bit7 (Servo On) and TFF (Torque feed forward) commands are accepted during retreat operation.
Refer to Chapter 7-7 for TFF.

4-2-1 Command code and command argument (Command bytes 1, 4–15)

Byte	bit 7	bit 6	bit 5	bit 4	bit 3	bit 2	bit 1	bit 0
1	TMG_CNT	Command_Code						
4–7	Command_Data1							
8–11	Command_Data2							
12–15	Command_Data3							

Title	Description
Command_Code	<ul style="list-style-type: none"> Set up the command code. Command code is classified into two types as cyclic command code for transmitting real-time data such as command position and non-cyclic command code for transmitting event-driven data such as parameter setup. Cyclic command code is assigned to bit 6 to 4 in byte 1 of command, and specifies the data for byte 4 to 7. Non-cyclic command code is assigned to bit 3 to 0 in byte 1 of command, and specifies the data for byte 8 to 15. Use of unsupported cyclic command causes Err. 86.1 “RTEX cyclic data error protection 2 alarm”. See the figure below for details.
TMG_CNT	<ul style="list-style-type: none"> Use in inter-axis full synchronous mode. • For details, refer to 4-2-1-1.
Command_Data1	<ul style="list-style-type: none"> Set up the command data specified by cyclic command code. For details, refer to the command description (Chapters 5 and 6).
Command_Data2	<ul style="list-style-type: none"> Set up the command data specified by non-cyclic command code. For details, refer to the command description (Chapters 5 and 6).
Command_Data3	<ul style="list-style-type: none"> Set up the command data specified by non-cyclic command code. For details, refer to the command description (Chapters 5 and 6).

Byte	bit 7	bit 6	bit 5	bit 4	bit 3	bit 2	bit 1	bit 0
1	TMG_CNT/ CMD_Error	Cyclic command code (Specify data of Bytes 4–7.)			Non-cyclic command code (Specify data of Bytes 8–15.)			

Application	
bit 7	Command Response
	TMG_CNT CMD_Error
0	Command normal
1	Command error

Cyclic command

bit 6–4	Application
0	NOP
1	Profile position control mode (PP)
2	Cyclic position control mode (CP)
3	Cyclic velocity control mode (CV)
4	Cyclic torque control mode (CV)
5–7	Reserved

Non-cyclic command

bit 3–0	Application
0	Normal command
1	Reset command
2	System ID command
3	Reserved
4	Return to home command
5	Alarm command
6	Parameter command
7	Profile command
8–9	Reserved
10	Monitor command
11–15	Reserved

Set the cyclic command code to NOP (bits 6–4:0) only when transmitting invalid data after canceling the reset, and specify the control mode to be used (PP, CP, CV or CT). Do not transmit NOP.

For details of each command, refer to Chapters 5 and 6.

4-2-1-1 TMG_CNT setup and inter-axis synchronous mode

When bit 1 of Pr.7.22 “RTEX function extended setup 1” is set at 1, the servo driver syncs its all internal control cycles to the timing of TMG_CNT.

Category	No.	Attribute	Parameter	Setting range	Unit	Description
7	22	R	RTEX function extended setup 1	-32768 -32767	—	<p>[bit 0] Set the data size of RTEX communication. 0: 16-byte mode 1: 32-byte mode</p> <p>[bit 1] Set the inter-axis synchronous mode that uses TMG_CNT. When not using TMG_CNT, set this bit to 0. 0: Inter-axis semi-synchronous mode 1: Inter-axis full-synchronous mode</p> <p>[bit4] External scale position information monitoring function under semi-closed control setting: 0 : Invalid 1 : Valid</p> <ul style="list-style-type: none"> Under full-closed control, external scale position information can be monitored regardless of the setting of this bit.

(1) Inter-axis semi-synchronous mode (Pr.7.22, bit 1 = 0)

In this mode, inter-axis synchronization will fail in some functions (e.g. Servo off sequence), although receiving timing of operation instructions such as position instruction is coincident.

- Do not use TMG_CNT.

(2) Inter-axis full-synchronous mode (Pr.7.22, bit 1 = 1)

This mode is used when MINAS-A6N's all internal control process start timings between 2 or more axes are to be synchronized. Some functions (e.g. Servo off sequence) other than operation instructions may also be synchronized.

- Set the same value to the TMG_CNT for all axes and update the count every 2 ms.
- If TMG_CNT is not counted up correctly, communication is not established (COM_LED is not lit in green) or inter-axis synchronization is not established.
- The time necessary to establish the communication (COM-LED is lit in green) varies depending on a pair of axes to be synchronized.
- Even if synchronization is established, inter-axis synchronization will not be established when start-stop communication error occurs at the start of the operation (especially at the beginning of the PP control mode).

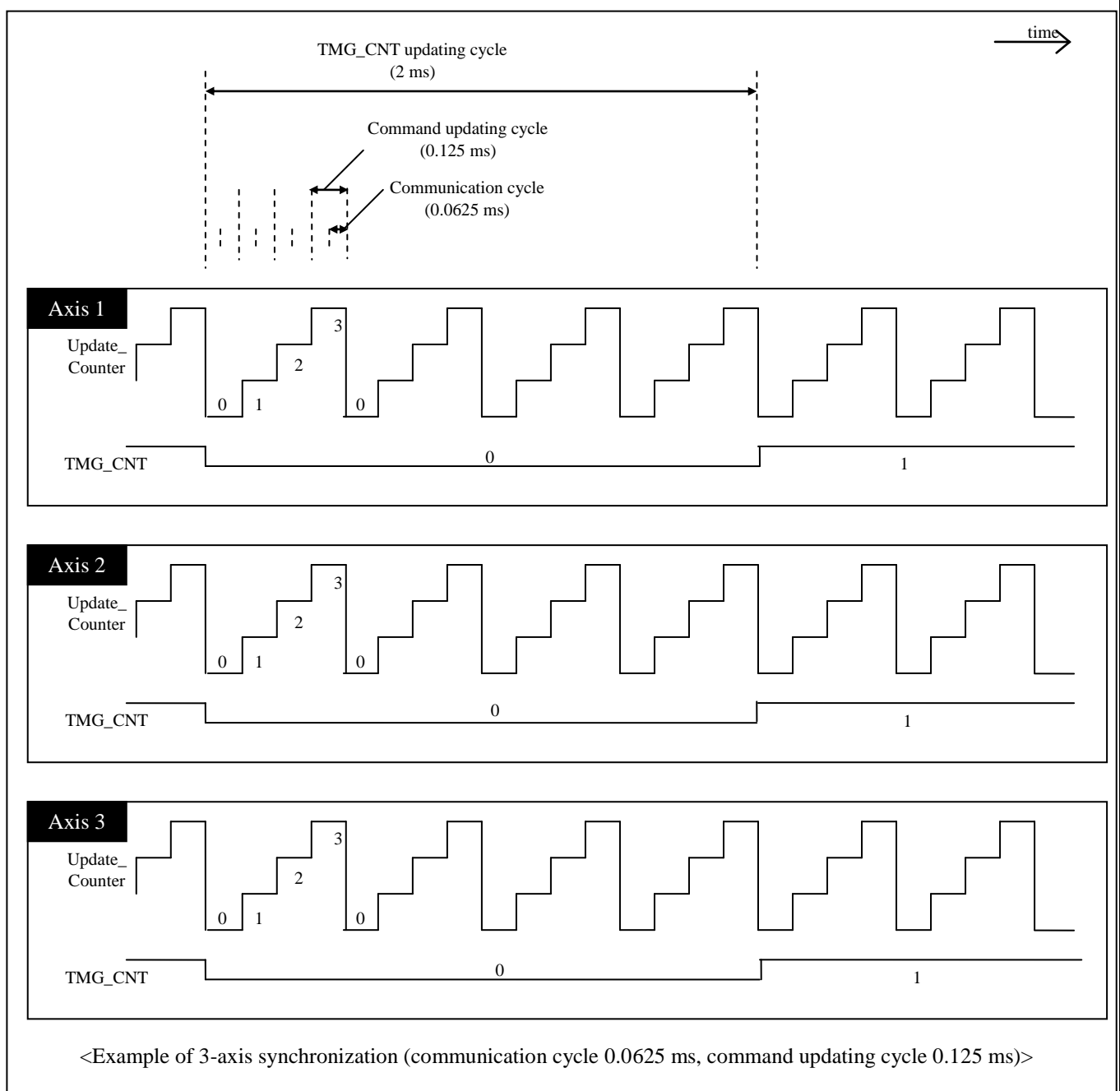

4-2-2 Command header (command byte 0)

Byte	bit 7	bit 6	bit 5	bit 4	bit 3	bit 2	bit 1	bit 0
0	C/R(0)	Update_Counter			MAC-ID (0-31)			

Title	Description
C/R	<ul style="list-style-type: none"> C/R bit distinguish command and response. Set this bit to 0 in command. If this bit is set to level other than 0, Err. 86.0 "RTEX cyclic data error protection 1" alarm will be generated.
Update_Counter	<ul style="list-style-type: none"> Set the count up value at the command updating cycle. The purpose is to detect the command updating timing at servo driver. The servo driver echoes back this data in the response, the counter can also be used as the watchdog timer.
MAC-ID	<ul style="list-style-type: none"> Set up the node address of the servo driver. If a node address different from actual setting value is used, Err. 86.0 "RTEX cyclic data error protection 1" alarm will be generated.

4-2-2-1 Update_Counter setup

Be sure to count up Update_Counter every command updating cycle at the data updating timing of the host controller. Otherwise, operation command is not correctly received.

When communication cycle is 250 μ s or less, set Update_Counter with the same value and update with the command updating cycle for all axes.

Because the counter used here is for the purpose of transferring the command updating timing to the servo driver, regardless of actual updating process, count up operation must be done even if the content of the command data block is unchanged.

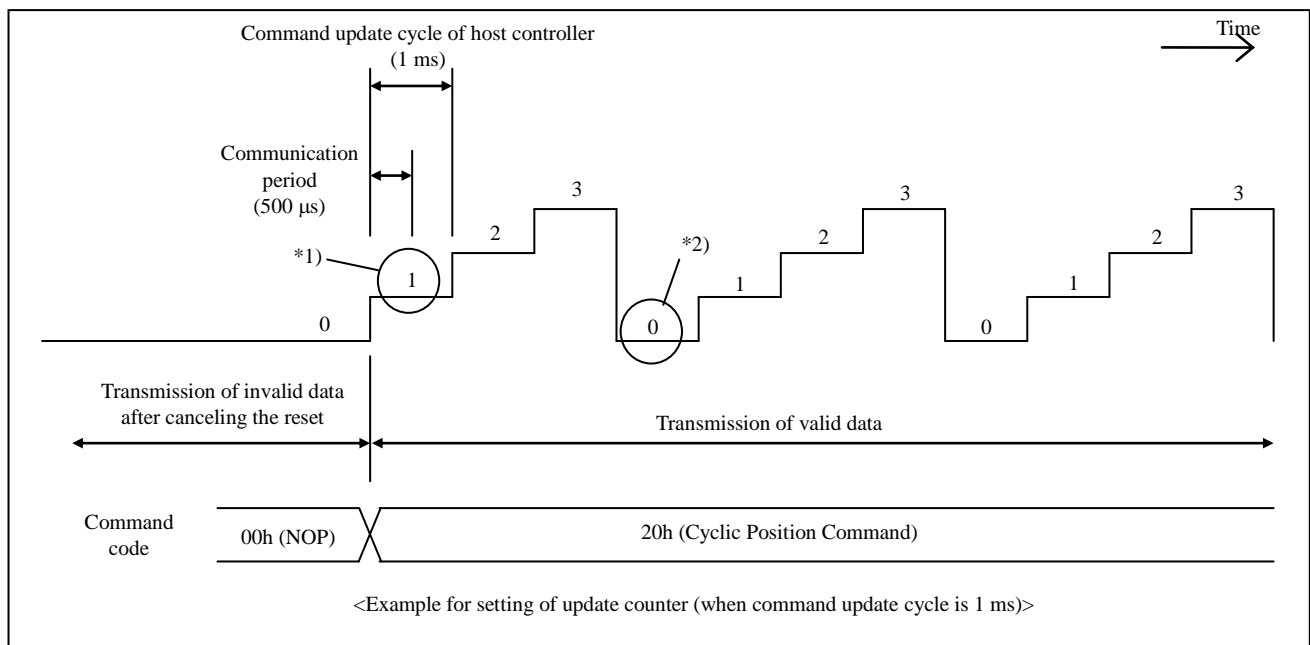

*1) Set 1 to update counter at transmission of 1st valid data.

*2) When the counter overflowed, repeat from 0.

4-2-3 Control bit (Command Bytes 2 and 3)

Byte	bit 7	bit 6	bit 5	bit 4	bit 3	bit 2	bit 1	bit 0
2	Servo_On	V_Full	0	Gain_SW	TL_SW	Homing_Ctrl	0	0
3	Hard_Stop	Smooth_Stop	Pause	0	SL_SW	0	EX-OUT2	EX-OUT1

Title	Description
Servo_On	<ul style="list-style-type: none"> • Set up the Servo-ON/OFF command. 0: Servo-OFF, 1: Servo-ON • When external servo on input (EX-SON) is assigned to interface connector (X4), the servo on command is issued as EX-SON and Servo_On are logically ANDed. ▪ See section 4-2-3-1 for details. ▪ Maintain the servo-on command during retreat operation (RET_Status=1). If it is not maintained, Err85.2/Err87.3 “Retreat operation error” will occur.
V_Full	<ul style="list-style-type: none"> • Set the command to switch to virtual full-closed control mode. 0: Full-closed control mode; 1: Virtual Full-closed control mode
Gain_SW	<ul style="list-style-type: none"> • Set up the gain changeover command. 0: Select 1st gain; 1: Select 2nd gain • This signal is enabled when real-time auto tuning is disabled, 2nd gain is enabled, and gain switching through RTEX communication is enabled. ▪ See section 4-2-3-2 for details.
TL_SW	<ul style="list-style-type: none"> • Set up the torque limit switching command. • This signal is enabled when Pr.5.21 “Selection of torque limit” is set to 3 or 4. ▪ See section 4-2-3-3 for details.
Homing_Ctrl	<ul style="list-style-type: none"> • Use this to control homing operation. • When this bit is at 1, the servo driver will detect the home reference trigger signal (e.g. Z-phase). • This signal will be invalid except homing command. ▪ See section 7-2 for details.
Hard_Stop	<ul style="list-style-type: none"> • In the profile control (PP) mode, immediately stop the internal command generation process and end the profile operation. ▪ See section 6-8-4 for details.
Smooth_Stop	<ul style="list-style-type: none"> • In the profile control (PP) mode, start and continue deceleration at the preset deceleration rate to fully stop the profile operation. ▪ See section 6-8-4 for details.
Pause	<ul style="list-style-type: none"> • In the profile control (PP) mode, start and continue deceleration at the preset deceleration rate to pause the profile operation. ▪ See section 6-8-4 for details.
SL_SW	<ul style="list-style-type: none"> • Set up the speed limit switching command when controlling the torque (CT). • This signal is valid when parameter Pr.3.17 “Selection of speed limit” is set to 1. ▪ See section 4-2-3-4 for details.
EX-OUT2 EX-OUT1	<ul style="list-style-type: none"> • Select the external output signal RTEX operation output (EX-OUT1/EX-OUT2). 0: Output transistor is OFF; 1: Output transistor is ON • This signal is enabled when RTEX operation output (EX-OUT1/EX-OUT2) is assigned to interface connector X4. • This signal does not affect the servo control. ▪ See section 4-2-3-5 for details.

4-2-3-1 Servo_On/off command (Servo_on)

Use this command to energize (servo on)/de-energize (servo off) the motor.

- When external servo on input (EX-SON) is assigned, the servo-on command for servo control process is enabled as both external servo on input (EX-SON) and this bit are in servo on state.

When the external servo-on input (EX-SON) is not assigned, only this bit is enabled.

In case of pin assignment, basically same function shall be assigned to one terminal under any types of control mode.

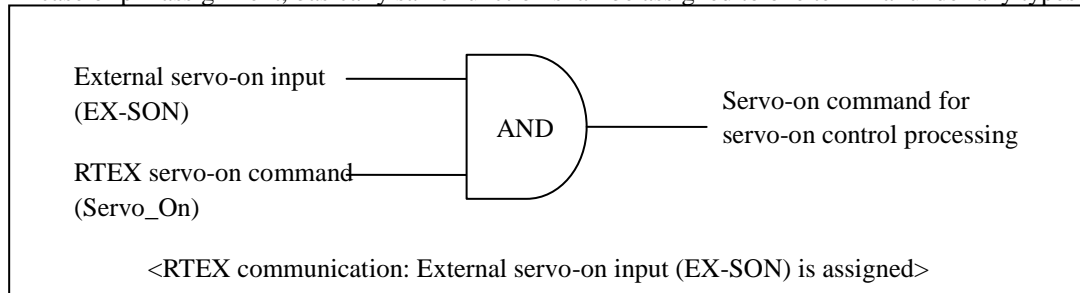

- Servo-on command cannot be used, if the servo is not ready for operation (in alarm condition or main power source is off), or motor is running (at 30 r/min or higher). Servo-ready condition can be verified by checking Byte 2, bit 6 (Servo_Ready) in the response.
- During servo off (clearing positional deviation), the command position in the servo driver follows up the actual motor position to minimize the positional deviation to 0. Therefore, to start CP control (cyclic position control) after servo is on, re-set the coordinate system of the host controller with servo-off state, set the actual position value to the command position, and then transmit the servo-on command. For detailed description, refer to Section 7-1-1.
- When the servo is turned off while the profile position control system is operating (In_Progress = 1), the profile process is canceled.
- During servo off, servo internal process remains position control even if cyclic command is CV/CT.

■ Instructions for use of the setup support software PANATERM

- When running “test run function”, “frequency response analyzing function (FFT)”, ”Z phase search function” or “fit gain function” by using the setup support software PANATERM issues servo-on command. This command is also enabled when the external servo-on (EX-SON) is assigned. If the external servo-on (EX-SON) is not assigned, only the servo-on command from the setup support software PANATERM is enabled.

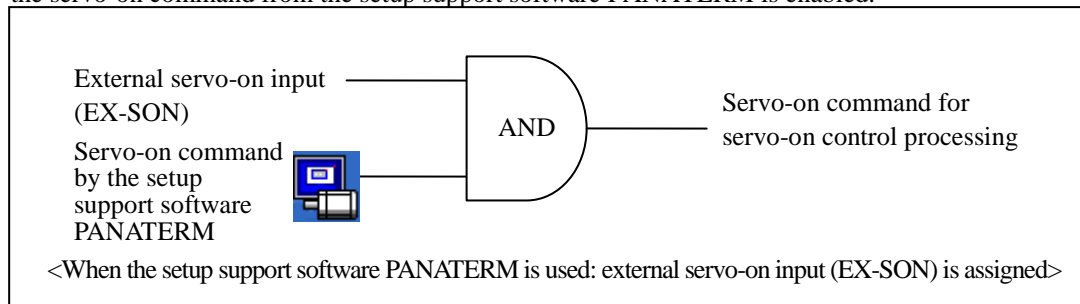

- Monitor value of servo-on input state on the setup support software PANATERM is “servo-on command to servo control process”.
- When running “test run function”, “frequency response analyzing function (FFT)”, “Z phase search function”, “fit gain function” or “pin assignment setting”, it is necessary to cut off RTEX communication or set Pr7.99 bit 0 to 1 in advance. By setting Pr7.99 bit 0 to 1, when RTEX Servo-ON command is Servo-OFF, “test run function” and other functions can be used in the state of the establishment of RTEX communication.

Class	No.	Attribute	Title	Range	Unit	Description
7	99	B	RTEX function extended setup 6	-32768 ~32767	—	bit0: PANATERM execution while establishing RTEX communication valid (0: Invalid, 1: Valid)

- When running ”test run function”, ”frequency response analyzing function (FFT)”, ”Z phase search function” or ”fit gain function” in the state of the establishment of RTEX communication, Warning D2 “PANATERM command execution warning” occurs, and the Servo-ON state by PANATERM command is informed.
In the Servo-ON state by PANATERM command, Servo-Active of RTEX response becomes off.
- When writing pin assignment information in the driver by ”pin assignment setting” in the state of the establishment of RTEX communication, Warning D2 “PANATERM command execution warning” occurs.
- The following RTEX commands cannot be used while a cause for Warning D2 is present.
 - Reset command (attribute C parameter validation mode)
 - Homing command
 - Parameter command (Write parameter)
- The ”test run function”, ”frequency response analyzing function (FFT)”, ”Z phase search function” and ”fit gain function” are accompanied with motor operation.
Be sure to secure the safety of your surroundings, for example, creating a state where you can turn off the power immediately, before execution.

4-2-3-2 Gain switching command (Gain_SW)

Class	No.	Attribute	Title	Range	Unit	Description
1	14	B	2nd gain setup	0-1	-	<p>Arrange this parameter when performing optimum adjustment by using the gain switching function.</p> <p>0: Fixed to 1st gain. Velocity loop operation is set to PI or P depending on the control bit Gain_SW of RTEX communication.</p> <p>Gain_SW = 0 -> PI operation Gain_SW = 1 -> P operation</p> <p>1: Enable gain switching of 1st gain (Pr.1.00-Pr.1.04) and 2nd gain (Pr.1.05-Pr.1.09).</p>

The gain can be changed by using Gain_SW provided that the real time auto-gain tuning is disabled, 2nd gain is enabled and gain switching through RTEX communication is enabled.

0: Select 1st gain

1: Select 2nd gain

Parameter to be set up		Setting value	Description
Pr.0.02	Real-time auto-gain tuning setup	0	Disable real-time auto-gain tuning
Pr.1.14	2nd gain setup	1	Enable 1st/2nd gain switching Disable P/PI control switching
Pr.1.15	Mode of position control switching	2	Gain switching through RTEX communication (Gain_SW)
Pr.1.20	Mode of velocity control switching	2	Gain switching through RTEX communication (Gain_SW)
Pr.1.24	Mode of torque control switching	2	Gain switching through RTEX communication (Gain_SW)

Switching of velocity loop, P/PI control through Gain_SW is possible when real-time auto-gain tuning is disabled and 2nd gain is disabled.

0: PI control (enable velocity loop integral)

1: P control (clear velocity loop integral)

Parameter to be set up		Setting value	Description
Pr.0.02	Real-time auto-gain tuning setup	0	Real-time auto-gain tuning function is disabled.
Pr.1.14	2nd gain setup	0	Enable 1st/2nd gain switching Disable P/PI control switching

4-2-3-3 Torque limit switching command (TL_SW)

Torque limit can be selected from TL_SW when Pr.5.21 “Selection of torque limit” setting value is 3 or 4.

Note that during torque control, the switching function is disabled and Pr.0.13 “1st torque limit” is enabled.

Class	No.	Attribute	Title	Range	Unit	Description																													
5	21	B	Selection of torque limit	0-4	-	<p>You can set up the torque limiting method</p> <table border="1"> <thead> <tr> <th rowspan="2">Setup value</th> <th colspan="2">TL_SW = 0</th> <th colspan="2">TL_SW = 1</th> </tr> <tr> <th>Negative direction</th> <th>Positive direction</th> <th>Negative direction</th> <th>Positive direction</th> </tr> </thead> <tbody> <tr> <td>1</td> <td colspan="4">Pr.0.13</td> </tr> <tr> <td>2</td> <td>Pr.5.22</td> <td>Pr.0.13</td> <td>Pr.5.22</td> <td>Pr.0.13</td> </tr> <tr> <td>3</td> <td colspan="2">Pr.0.13</td> <td colspan="2">Pr.5.22</td> </tr> <tr> <td>4</td> <td>Pr.5.22</td> <td>Pr.0.13</td> <td>Pr.5.26</td> <td>Pr.5.25</td> </tr> </tbody> </table> <ul style="list-style-type: none"> Pr.0.13 “1st torque limit”, Pr.5.22 “2nd torque limit”, Pr.5.25 “Positive direction torque limit”, Pr.5.26 “Negative direction torque limit” <p>When 0 is set, 1 will be internally set.</p>	Setup value	TL_SW = 0		TL_SW = 1		Negative direction	Positive direction	Negative direction	Positive direction	1	Pr.0.13				2	Pr.5.22	Pr.0.13	Pr.5.22	Pr.0.13	3	Pr.0.13		Pr.5.22		4	Pr.5.22	Pr.0.13	Pr.5.26	Pr.5.25
Setup value	TL_SW = 0		TL_SW = 1																																
	Negative direction	Positive direction	Negative direction	Positive direction																															
1	Pr.0.13																																		
2	Pr.5.22	Pr.0.13	Pr.5.22	Pr.0.13																															
3	Pr.0.13		Pr.5.22																																
4	Pr.5.22	Pr.0.13	Pr.5.26	Pr.5.25																															

4-2-3-4 Speed limit switching command (SL_SW)

When the setting value of Pr.3.17 “Selection of speed limit” is 1, the speed limit value during torque controlling can be selected from SL_SW.

Class	No.	Attribute	Title	Range	Unit	Description									
3	17	B	Selection of speed limit	0-1	-	<p>Set the speed limit value selection method for torque controlling.</p> <table border="1"> <thead> <tr> <th>Setup value</th> <th>SL_SW = 0</th> <th>SL_SW = 1</th> </tr> </thead> <tbody> <tr> <td>0</td> <td colspan="2">Pr.3.21</td> </tr> <tr> <td>1</td> <td>Pr.3.21</td> <td>Pr.3.22</td> </tr> </tbody> </table>	Setup value	SL_SW = 0	SL_SW = 1	0	Pr.3.21		1	Pr.3.21	Pr.3.22
Setup value	SL_SW = 0	SL_SW = 1													
0	Pr.3.21														
1	Pr.3.21	Pr.3.22													
3	21	B	Speed limit value 1	0-20000	r/min	<p>Set the speed limit value for torque controlling. During torque controlling, the speed set by the speed limit value will not be exceeded. The internal value is limited by the smallest setting speed of Pr 5.13 “Over-speed level setup”, Pr 6.15 “2nd over-speed level setup” and internal value of the over-speed protection level.</p>									
3	22	B	Speed limit value 2	0-20000	r/min	<p>When Pr.3.17 “Selection of speed limit” = 1, set the speed limit value as specified by SL_SW = 1. The internal value is limited by the smallest setting speed of Pr 5.13 “Over-speed level setup”, Pr 6.15 “2nd over-speed level setup” and internal value of the over-speed protection level.</p>									

4-2-3-5 External output signal operation instruction (EX-OUT 1/2)

The external output signal S01 and S02 from the interface connector (X4) can be controlled by assigning RTEX operation output 1 (EX-OUT 1) and RTEX operation output 2 (EX-OUT 2) to these signals.

State of the output transistor of RTEX operation output 1 (2) is as shown below: after establishment of RTEX, before establishment of RTEX communication after resetting and shutoff after establishment of RTEX. Note that control bit cannot be used for controlling through RTEX communication if RTEX communication is not established after resetting or if shutoff occurs after establishment of RTEX. Safety of the system should be taken into consideration when setting the system.

Class	No.	Attribute	Title	Range	Unit	Description
7	24	C	RTEX function extended setup 3	-32768 -32767	-	bit0: Setup EX-OUT 1 output state during communication cutoff after establishment of RTEX communication. 0: Hold 1: Initialize (output when EX-OUT 1 = 0) bit1: Setup EX-OUT 2 output state during communication cutoff after establishment of RTEX communication. 0: Hold 1: Initialize (output when EX-OUT 2 = 0)

Signal	Symbol	Pr.7.24 RTEX function expansion setup 3	RTEX control bit	State of output transistor		
				Communication established	Reset	Communication blocked
RTEX operation output 1	EX-OUT1	bit0 = 0 (Hold)	EX-OUT1 = 0	OFF	OFF	Hold
			EX-OUT1 = 1	ON		
		bit0 = 1 (Initialize)	EX-OUT1 = 0	OFF	OFF	OFF
			EX-OUT1 = 1	ON		
RTEX operation output 2	EX-OUT2	bit1 = 0 (Hold)	EX-OUT2 = 0	OFF	OFF	Hold
			EX-OUT2 = 1	ON		
		bit1 = 1 (Initialize)	EX-OUT2 = 0	OFF	OFF	OFF
			EX-OUT2 = 1	ON		

4-3 Data block in response (16-byte/32-byte)

Response will be transmitted from the slave (servo driver) to the master (host controller).

Byte	bit 7	bit 6	bit 5	bit 4	bit 3	bit 2	bit 1	bit 0
0	C/R(1)	Update_Counter_Echo		Actual_MAC-ID (0-31)				
1	CMD_Error	Command_Code_Echo						
2	Servo_Active	Servo_Ready	Alarm	Warning	Torque_Limited	Homing_Complete	In_Progress /AC_OFF /Pr7.112 *1	In_Position
3	E-STOP	SI-MON4 /EX-SON	SI-MON3 /EXT3 /STOP	SI-MON2 /EXT2 /RET	SI-MON1 /EXT1	HOME	POT /NOT	NOT /POT
4	Response_Data1							L
5								ML
6								MH
7								H
8	Response_Data2							L
9								ML
10								MH
11								H
12	Response_Data3							L
13								ML
14								MH
15								H

- Notes:
- Command code at command data block defines the contents from byte 4 to byte 15.
 - Disposition of multiple byte data is little endian, which means that lower byte is first.
 - Replies 0 at unused bits.

*1) The output signal for Byte2 bit1 of the response can be selected by combining Pr7.23 and Pr7.112.

Pr7.23		Pr7.112	内容
bit15	bit8		
0	0	-	In_Progress
	1	-	AC_OFF
1	-	0	RET_Status
	-	1	V_Full_Status

4-3-1 Command_Code_Echo and Response_Data (Response byte 1, 4 to 15)

Byte	bit 7	bit 6	bit 5	bit 4	bit 3	bit 2	bit 1	bit 0
1	CMD_Error	Command_Code_Echo						
4-7	Response_Data1							
8-11	Response_Data2							
12-15	Response_Data3							

Title	Description
CMD_Error	<ul style="list-style-type: none"> Return 1 at the command error occurred. Set to 1 when an error occurs upon receiving the command (before processing it).
Command_Code_Echo	<ul style="list-style-type: none"> Return the echo-back value of command code.
Response_Data1	<ul style="list-style-type: none"> Return the monitor data specified by Pr.7.29 “RTEX monitor select 1”. Specify the monitor data by setting monitor command Standard Type_Code (8-bit) to Pr.7.29. For Standard Type_Code details, refer to clause 6-9-1. When Pr.7.29 = 0, actual position (New Type_Code = 07h) is returned as compatibility with MINAS-A4N . Arrangement of byte data is little endian, which means that lower byte is first.
Response_Data2	<ul style="list-style-type: none"> Return the response data specified by non-cyclic command code. When non-cyclic command code is 0h (normal command), returns the monitor data specified in Pr.7.30 “RTEX monitor select 2”. Specify the monitor data by setting monitor command Standard Type_Code (8-bit) to Pr.7.30. For Standard Type_Code details, refer to clause 6-9-1. When Pr.7.30 = 0, actual speed (New Type_Code = 05h) is returned as compatibility with MINAS-A4N. Arrangement of byte data is little endian, which means that lower byte is first.
Response_Data3	<ul style="list-style-type: none"> Return the response data specified by non-cyclic command code. When non-cyclic command code is 0h (normal command), returns the monitor data specified in Pr.7.31 “RTEX monitor select 3”. Specify the monitor data by setting monitor command Standard Type_Code (8-bit) to Pr.7.31. For Standard Type_Code details, refer to clause 6-9-1. When Pr.7.31 = 0, torque (New Type_Code = 06h) is returned as compatibility with MINAS-A4N. Arrangement of byte data is little endian, which means that lower byte is first.

4-3-2 Response header (Response byte 0)

Byte	bit 7	bit 6	bit 5	bit 4	bit 3	bit 2	bit 1	bit 0
0	C/R(1)	Update_Counter_Echo	Actual_MAC-ID (0-31)					

Title	Description
C/R	<ul style="list-style-type: none"> • C/R bit distinguish command and response. • Return 1 as a response.
Update_Counter_Echo	<ul style="list-style-type: none"> • Return the echo-back value of Update_Counter. • Use this to check whether the drive has received properly.
Actual_MAC-ID	<ul style="list-style-type: none"> • Return the node address of the servo driver. • This is not echo-back, but actual value that is the setup of the RSW at power-up.

4-3-3 Status flag (Response byte 2)

Byte	bit 7	bit 6	bit 5	bit 4	bit 3	bit 2	bit 1	bit 0
2	Servo _Active	Servo _Ready	Alarm	Warning	Torque _Limited	Homing _Complete	In_Progress /AC_OFF	In_Position

Title	Description
Servo_Active	<ul style="list-style-type: none"> Return 1 at Servo-ON state (motor energized). Also becomes servo-off state during deceleration with dynamic brake. In case of Pr7.24 “RTEX function extended setup 3” bit4=1, the Servo_Active flag forcibly returns the servo OFF (non-energized) state until it becomes possible to accept commands after servo ON. Return 0 in the Servo-ON state by PANATERM command.
Servo_Ready	<ul style="list-style-type: none"> Return 1 at Servo-Ready (transitionable to Servo-ON) state. Becomes 1 when all of the 3 conditions are satisfied, “Main power established”, “No alarm occurrence” and “Synchronization between the servo and the communication established”. For details, refer to Section 4-3-3-1.
Alarm	<ul style="list-style-type: none"> Return 1 at alarm occurrence
Warning	<ul style="list-style-type: none"> Return 1 at warning occurrence Determine whether to latch the warning state by the setting of Pr.6.27 “Warning latch state setup”. For details, refer to technical reference Functional Specification “Section 7-3”.
Torque_Limited	<ul style="list-style-type: none"> Return 1 at torque limited. Set to 1 when the internal torque command is limited by a parameter, etc. Output condition during torque control can be set by Pr.7.03 “Output setup during torque limit”. For details, refer to technical reference Functional Specification “Section 6-1”.
Homing_Complete	<ul style="list-style-type: none"> Return 1 at homing operation completed (except the latch mode and latch mode with stop function) and holds 1 after that (secure home position). Clears to 0 at reception of homing command (except the latch mode and latch mode with stop function). In absolute mode (when using the absolute encoder in the absolute system or using the external scale in the absolute system in full-closed control mode), since the home position has been secured from the time when the control power is turned on, the initial value becomes 1, while on the other hand, it becomes 0 in incremental mode. As with in the case of turning on of the control power, the position information and this bit are also initialized as the reset command ($\square 1h$) is executed. Also at the completion of running “test run function”, “frequency response analyzing function (FFT)”, “clearing of multi-turn data of absolute encoder”, “Z phase search function”, “fit gain function” or “pin assignment setting” from the setup support software, the position information is initialized just the same as when the control power is turned on, and this bit is also initialized. It is set to 0 after retreat operation under incremental mode.
In_Progress /AC_OFF /Pr7.112	<ul style="list-style-type: none"> During setting of In_Progress and in profile position control (PP) mode, returns 1 while internal command position is being generated, and returns 0 upon completion of the internal command position generation (transfer out). Return 1 upon occurrence of main power off alarm during AC_OFF setting. For the read signal selection method, see 4-3-3-2. <ul style="list-style-type: none"> 1 is returned when Pr7.23 bit15 = 1 (follow the setting in Pr7.112), RET_Status is set for Pr7.112 “RTEX communication status flag selection,” and retreat operation and Err85.2/Err87.3 “Retreat operation error” judgment are both being executed. Maintain Servo_On=1 during retreat operation. Err85.2/Err87.3 “Retreat operation error” will occur if it is not maintained. For details about the method for selecting the signal to be read, refer to Section 4-3-3-2. <ul style="list-style-type: none"> 1 is returned when Pr7.23 bit15 = 1 (follow the setting in Pr7.112), V_Full_Status is set for Pr7.112 “RTEX communication status flag selection,” and the system is in virtual full-closed control mode.

(To be continued)

Title	Description		
In_Position	<ul style="list-style-type: none"> The function of flag depends on the control mode as shown below. 		
	Function	Control mode	Description
	Positioning complete	Position control (CP, PP)	<ul style="list-style-type: none"> Return 1 upon completion of homing. As with for positioning complete output (INP, external output signal), set the output condition through parameters Pr.4.31 "Positioning complete range, Pr.4.32 "Positioning complete output setup" and Pr.4.33 INP hold time. For details, refer to Technical Reference Functional Specification "Section 4-2-4". 1 is returned when virtual full-closed control mode amount of external scale position change judgment function is effective (Pr6.98 bit9=1) under virtual full-closed control mode state, and when the amount of external scale position change reaches the setting value in Pr3.32 "Virtual full-closed control mode amount of external scale position change judgment threshold value" or larger. For details, refer to Functions Specification edition of the Technical Reference (Section 5-2-19).
Velocity coincidence	Velocity control (CV)	<ul style="list-style-type: none"> Return 1 when the motor actual speed and command velocity are the same. As with for the speed coincidence output (V-COIN) (external output signal), set the output condition through Pr.4.35 "Speed coincidence range". For details, refer to Technical Reference Functional Specification "Section 4-3-2". 	
	Torque control (CT)	<ul style="list-style-type: none"> Return 1 when the motor actual speed and the speed limit value are the same. Set the output condition through Pr.4.35 "Speed coincidence range". For details, refer to Technical Reference Functional Specification "Section 4-3-2". 	

4-3-3-1 Servo Ready state (Servo_Ready)

Return 1 at Servo-Ready (transitionable to Servo-ON) state.

- Becomes 1 when all of the 3 conditions are satisfied, “Main power established”, “No alarm occurrence” and “Synchronization between the servo and the communication established”.

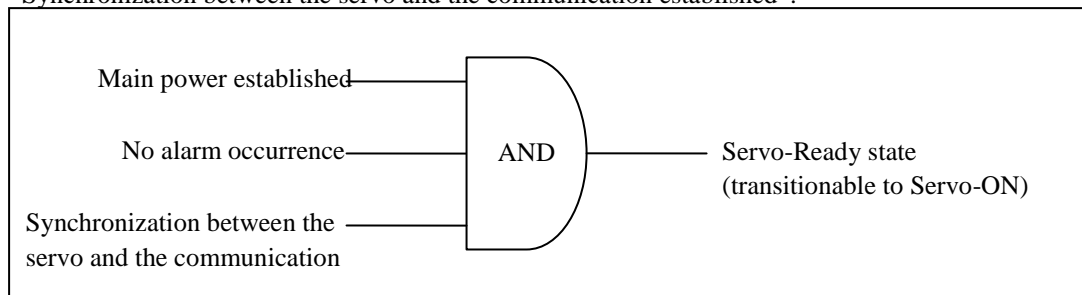

- If the ratio of communication cycle and command updating cycle is not 1:1, in the inter-axis semi- synchronous mode (Pr.7.22 bit 1 = 0), or if TMG_CNT is not correctly counted up in the inter-axis full-synchronous mode (Pr.7.22 bit 1 = 1), servo-ready state is not possible.
- As an exceptional processing, during processing of reset command, in attribute C parameter validation mode, the value is left undefined.

4-3-3-2 Internal position command generation state (In_Progress)/main power off alarm state (AC_OFF)

Using bit 8 of Pr.7.23 “RTEX function extended setup 2”, select the signal to which bit 1 of status flag is to be assigned.

Class	No.	Attribute	Title	Range	Unit	Description
7	23	B	RTEX function extended setup 2	-32768 ~32767	-	bit8:RTEX status selection between In_Progress and AC_OFF 0: In_Progress, 1: AC_OFF * It is connected to the setting of bit15. bit9:Selects whethbit15:Extension of RTEX status selection for the setting value of In_Progress/AC_OFF/Pr7.112 0:Complying with the setting (In_Progress/AC_OFF) of Pr7.23 bit8 1:The signal designated by Pr7.112 is output. * For description on other bits, refer to Technical reference Functional Specification “Section 9-1”.
7	112	B	Selection of RTEX communication status flag	0~1	-	Select the signal returned with the status flag (Byte2 bit1) of RTEX response in the case of Pr7.23 bit15=1 0:RET_status (the status during execution of escape operation) is returned.

4-3-4 Input signal status flag (Response byte 3)

Byte3 at Response is the status area of the external input signal from the interface connector, (X4).

Byte	bit 7	bit 6	bit 5	bit 4	bit 3	bit 2	bit 1	bit 0
3	SI-MON5 /E-STOP	SI-MON4 /EX-SON	SI-MON3 /EXT3 /STOP	SI-MON2 /EXT2 /RET	SI-MON1 /EXT1	HOME	POT /NOT	NOT /POT

- On MINAS-A6N, 8 external input connection terminals are provided to which functions and logics may be assigned individually. For details, refer to Technical Reference Functional Specification “Section 2-4-1”.
- When function is not assigned to a terminal, corresponding bit in this status flag is set to 0.
A terminal can be assigned with 2 or more functions, but only 1 per control mode. However, this is confusion because some functions are enabled and some are disabled upon changing control modes: Ideally, functions allocated to a terminal should be common to all control modes.
- Because the following pair of designations are assigned to the same bit position, only one of designations can be selected: SI-MON1/EXT1, SI-MON2/EXT2/RET, SI-MON3/EXT3/STOP, SI-MON4/EX-SON and SI-MON5/E-STOP. If attempt is made to allocate 2 or more functions to the same bit, Err.33.0 “I/F input multiple allocation error 1 protect” or Err.33.1 “I/F input multiple allocation error 2 protect” will be enabled.
- This status returns the logical status (1: function active) but not physical status (input transistor ON/OFF state). However, status of driver inhibit input (POT/NOT) can be logically set.
- EXT1, EXT2 and EXT3 indicate the state of input signal but not complete state of latch.
- For driver inhibit input (POT/NOT), status response condition, status bit arrangement and status logic can be set as shown below while the function is disabled (Pr.5.04 = 1), through the parameter Pr7.23 “RTEX function extended setup 2”.
Because CCWL and CWL used on MINAS-A4N series are changed to POT and NOT, respectively, on MINAS-A6N series, correctly set this parameter and Pr0.00 “Rotational direction setup” to make the functions effective on MINAS-A4N. For details, refer to Technical Reference Functional Specification “Section 4-1”.

Class	No.	Attribute	Title	Range	Unit	Description
7	23	B	RTEX function extended setup 2	-32768 -32767	-	<p>[bit 2] Set RTEX status response condition when POT/NOT function is disabled Pr.5.04 = 1. 0: Enable in terms of RTEX status (response) 1: Disable in terms of RTEX status (not response = normally 0)</p> <p>[bit 3] POT/NOT RTEX status bit arrangement set up 0: POT at bit 1; NOT at bit 0 1: NOT at bit 1; POT at bit 0</p> <p>[bit 6] POT/NOT RTEX status logic set up 0: No inversion (active 1) 1: Inversion (active 0)</p> <ul style="list-style-type: none"> ▪ For description on other bits, refer to Technical reference Functional Specification “Section 9-1”.

- Noise filtering process is performed when capturing the input signals within the servo driver, and this causes some detection delay. Total delay time including the transmission delay in communication will be several ms. If this delay time gives inconvenience, provide the system that directly connects the sensor signal to host controller.

4-4 Command data block of sub-command (only for 32-byte mode)

Sub-command is transferred from the master (host controller) to the slave (servo driver).

Byte	bit7	bit6	bit5	bit4	bit3	bit2	bit1	bit0
16	Sub_Chk	0	0	0	Sub_Command_Code			
17	Sub_Type_Code							
18	Sub_Index							
19								
20	Sub_Command_Data1							L
21								ML
22								MH
23								H
24	Sub_Command_Data2							L
25								ML
26								MH
27								H
28	Sub_Command_Data3							L
29								ML
30								MH
31								H

- Notes:
- Specify the arrangement of Byte 17 to Byte 23 by using Byte 16 sub-command codes.
 - Arrangement of data bytes is little endian which means that lower byte is first.
 - Set unused bit to 0.

4-4-1 Sub-command code and sub-command argument (Command bytes 16 to 31)

Byte	bit7	bit6	bit5	bit4	bit3	bit2	bit1	bit0
16	Sub_Chk	0	0	0	Sub_Command_Code			
17	Sub_Type_Code							
18-19	Sub_Index							
20-23	Sub_Command_Data1							
24-27	Sub_Command_Data2							
28-31	Sub_Command_Data3							

Title	Description								
Sub_Chk	<ul style="list-style-type: none"> Used to check whether a sub-command frame or not. Be sure to set to 1. If this bit is 0 in the 32-byte mode, Err.86.0 "RTEX cyclic data error protection 1" will occur. 								
Sub_Command_Code	<ul style="list-style-type: none"> Used to set sub-command code. Fundamental function is the same as that of equivalent non-cyclic command. <p>Below shows corresponding non-cyclic command (sub-command).</p> <table border="1"> <thead> <tr> <th>Sub-command code</th> <th>Name of sub-command</th> </tr> </thead> <tbody> <tr> <td>0h</td> <td>Normally</td> </tr> <tr> <td>2h</td> <td>System ID</td> </tr> <tr> <td>Ah</td> <td>Monitor</td> </tr> </tbody> </table>	Sub-command code	Name of sub-command	0h	Normally	2h	System ID	Ah	Monitor
Sub-command code	Name of sub-command								
0h	Normally								
2h	System ID								
Ah	Monitor								
Sub_Type_Code	<ul style="list-style-type: none"> Set the command data to be specified by sub-command code. 								
Sub_Index	<ul style="list-style-type: none"> Set the command data to be specified by sub-command code. 								
Sub_Command_Data1	<ul style="list-style-type: none"> Set the command data to be specified by sub-command code. 								
Sub_Command_Data2	<ul style="list-style-type: none"> Set the data (Feed forward data) selected through Pr.7.36 "RTEX command setting 2". See 7-7 for details. 								
Sub_Command_Data3	<ul style="list-style-type: none"> Set the data (Feed forward data) selected through Pr.7.37 "RTEX command setting 3". See 7-7 for details. 								

For details of the sub-commands, refer to Chapter 6.

4-5 Response data block of sub-command (only for 32-byte mode)

Response of sub-command is transferred from the slave (servo driver) to master (host controller).

Byte	bit7	bit6	bit5	bit4	bit3	bit2	bit1	bit0	
16	Sub_ CMD_Err	Sub_ERR	Sub_WNG	Sub_Busy	Sub_Command_Code_Echo				
17	Sub_Type_Code_Echo								
18	Sub_Index_Echo								
19									
20									L
21	Sub_Response_Data1								ML
22									MH
23									H
24									L
25	Sub_Response_Data2								ML
26									MH
27									H
28									L
29	Sub_Response_Data3								ML
30									MH
31									H

- Notes:
- Specify the arrangement of Byte 17 to Byte 23 by using Byte 16 sub-command codes.
 - Arrangement of data bytes is little endian which means that lower byte is first.

4-5-1 Sub-command code echo and response data (Command bytes 16 to 31)

Byte	bit7	bit6	bit5	bit4	bit3	bit2	bit1	bit0
16	Sub_CMD_Err	Sub_ERR	Sub_WNG	Sub_Busy	Sub_Command_Code_Echo			
17	Sub_Type_Code_Echo							
18-19	Sub_Index_Echo							
20-23	Sub_Response_Data1							
24-27	Sub_Response_Data2							
28-31	Sub_Response_Data3							

Title	Description
Sub_CMD_Err	<ul style="list-style-type: none"> Return 1 upon sub-command error. Set this bit to 1 when error occurs upon receiving the sub-command (before executing it).
Sub_ERR	<ul style="list-style-type: none"> Indicates the state of the sub-command error. Set this bit to 1 when error occurs while processing after receiving the sub-command.
Sub_WNG	<ul style="list-style-type: none"> Indicates the state of the sub-command error. Set this bit to 1 when problem is found after processing the command.
Sub_Busy	<ul style="list-style-type: none"> Indicates the state of the sub-command error. Remain this bit at 1 while processing the command.
Sub_Command_Code_Echo	<ul style="list-style-type: none"> Return echo back value of Sub_Command_Code.
Sub_Type_Code_Echo	<ul style="list-style-type: none"> Return echo back value of Sub_Type_Code.
Sub_Index_Echo	<ul style="list-style-type: none"> Return echo back value of Sub_Index.
Sub_Response_Data1	<ul style="list-style-type: none"> Return the response data specified by sub command code. Return the monitor data specified through Pr.7.32 "RTEX monitor select 4" when the sub-command code is 0h (normal command). Specify the monitor data by setting monitor command Standard Type_Code (8 bits) to Pr.7.32. For Standard Type_Code details, refer to 6-9-1. Return 0 when Pr.7.32 = 0. Arrangement of data bytes is little endian which means that lower byte is first.
Sub_Response_Data2	<ul style="list-style-type: none"> Return the monitor data specified by Pr.7.33 "RTEX monitor select 5". Specify the monitor data by setting monitor command Standard Type_Code (8 bits) to Pr.7.33. For Standard Type_Code details, refer to 6-9-1. Return 0 when Pr.7.33 = 0. Arrangement of data bytes is little endian which means that lower byte is first.
Sub_Response_Data3	<ul style="list-style-type: none"> Return the monitor data specified by Pr.7.34 "RTEX monitor select 6". Specify the monitor data by setting monitor command Standard Type_Code (8 bits) to Pr.7.34. For Standard Type_Code details, refer to 6-9-1. Return 0 when Pr.7.34 = 0. Arrangement of data bytes is little endian which means that lower byte is first.

5. Cyclic Command Description

5-1 Cyclic command list

Cyclic command requires no transfer procedure. That is, when received, it directly reflects on the control. The cyclic command selects the control mode in the servo driver.

Supports only position control in case of full-closed control. Command error will occur when CV (velocity control) or CT (torque control) is received.

For relationship between the control mode and communication cycle/command updating cycle, refer to Section 2-5.

Control mode	Abbreviation	Command _Code	Description
NOP	NOP	0□h	For temporary transmission of invalid data immediately after establishment of the network. Never use this command for any other purpose. Upon receiving this command, control is performed based on the previously received command.
Profile Position Mode	PP	1□h	In this control mode, the target position, target speed and acceleration/deceleration speed (parameters) are specified and the position command is generated in the servo driver. For the operation command update (transmission), input when approx. 100 ms has elapsed after the servo ON.
Cyclic Position Mode	CP	2□h	In this mode, the host controller generates the position command and updates it (or transmits updated command) at the command updating cycle. For the operation command update (transmission), input when approx. 100 ms has elapsed after the servo ON.
Cyclic Velocity Mode	CV	3□h	In this mode, the host controller generates the velocity command and updates it (or transmits updated command) at the communication cycle. For the operation command update (transmission), input when approx. 100 ms has elapsed after the servo ON.
Cyclic Torque Mode	CT	4□h	In this mode, the host controller generates the torque command and updates it (or transmits updated command) at the communication cycle. For the operation command update (transmission), input when approx. 100 ms has elapsed after the servo ON. * When this command is received in Block Diagram of Tow-degree-of-freedom Mode, it causes the command error.

5-2 NOP command (Command code: 0□h)

This is for the temporary transmission of invalid data after the network has been established.

For NOP command, reset command and system ID command, which are non-cyclic commands, can be used.

The servo driver will control based on the previous command.

Control bits (Byte 2–3) are also invalid (previous data is retained).

If NOP command is transmitted in servo-on state, the control bit is disabled, inhibiting servo off.

	Command								Response									
	Byte	bit7	6	5	4	3	2	1	0	Byte	bit7	6	5	4	3	2	1	0
Cyclic	0	C (0)	Update_Counter		MAC-ID				0	R (1)	Update_Counter_Echo		Actual_MAC-ID					
	1	TMG_ CNT	Command_Code (00h)						1	CMD_ Error	Command_Code_Echo (00h)							
	2	Optional						2	Status_Flags									
	3							3										
	4							L	4									
	5	<Command_Data1>						ML	5	<Response_Data1>								
	6	Optional						MH	6	Default: Actual_Position (APOS) [Command unit]								
7							H	7										
Non-cyclic	8							L	8	<Response_Data2>								
	9	<Command_Data2>						ML	9	Default: Actual_Speed (ASPD)								
	10	Optional						MH	10	[Command unit/s] or [r/min]								
	11							H	11									
	12							L	12	<Response_Data3>								
	13	<Command_Data3>						ML	13	Default: Torque (TRQ)								
	14	Optional						MH	14	[0.1%]								
15							H	15										

Title	Command	Response						
<Response_Data1> Actual_Position (APOS)	–	Default: Motor actual position [Size]: Signed 32-bit [Unit]: Command unit						
<Response_Data2> Actual_Speed (ASPD)	–	Default: Motor actual speed [Size]: Signed 32-bit [Unit]: Setting value of Pr.7.25 “RTEX speed unit setup” <table border="1" style="margin-left: auto; margin-right: auto;"> <thead> <tr> <th>Pr.7.25</th> <th>Unit</th> </tr> </thead> <tbody> <tr> <td>0</td> <td>[r/min]</td> </tr> <tr> <td>1</td> <td>[Command unit/s]</td> </tr> </tbody> </table>	Pr.7.25	Unit	0	[r/min]	1	[Command unit/s]
Pr.7.25	Unit							
0	[r/min]							
1	[Command unit/s]							
<Response_Data3> Torque (TRQ)	–	Default: Instruction torque to motor [Size]: Signed 32-bit [Unit]: 0.1%						

- For selection method of Response_Data 1/2/3, see 4-3-1.

5-3 Profile position control (PP) command (Command code: 1□h)

In this position control mode, the target position, target speed and acceleration/deceleration speed are specified and the servo driver internally generates the position command.

For the operation command update (transmission), input when approx. 100 ms has elapsed after the servo ON.

Upon receiving this command, the servo driver switches the internal control mode to the position control.

For detailed block diagram of the position control, refer to Technical Reference Functional Specification “Section 5-2-1”.

Position control shall be made using external scale under full-closed control.

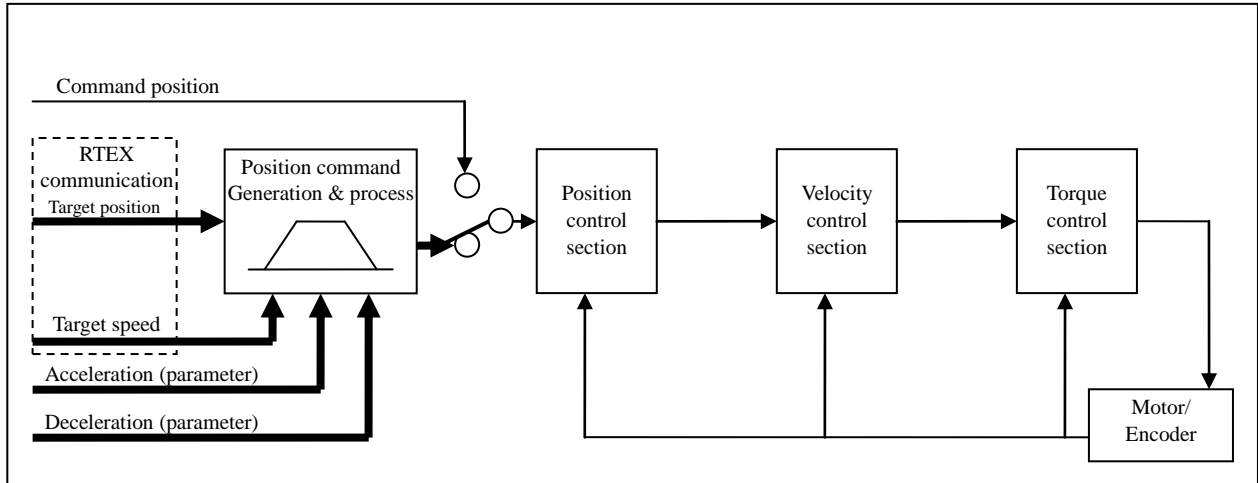

	Byte	Command								Byte	Response									
		bit7	6	5	4	3	2	1	0		bit7	6	5	4	3	2	1	0		
Cyclic	0	C (0)	Update_Counter		MAC-ID					0	R (1)	Update_Counter_Echo		Actual_MAC-ID						
	1	TMG_CNT	Command_Code (1□h)								1	CMD_Error	Command_Code_Echo (1□h)							
	2	Control_Bits								2	Status_Flags									
	3									3										
	4	<Command_Data1> Target_Position (TPOS) [Command unit]								L	4	<Response_Data1> Default: Actual_Position (APOS) [Command unit]								
	5									ML	5									
	6									MH	6									
7	H									7										
Non-cyclic	8	<Command_Data2>								L	8	<Response_Data2>								
	9									ML	9									
	10	Dependent on non-cyclic command								MH	10	Dependent on non-cyclic command								
	11									H	11									
	12	<Command_Data3>								L	12	<Response_Data3>								
	13									ML	13									
	14									MH	14									
15	H									15										

Title	Command	Response
<Command_Data1> Target_Position (TPOS)	Target position (absolute position) [Size]: Signed 32-bit [Unit]: Instruction unit [Setting range]: 80000000h-7FFFFFFFh (-2147483648 to 2147483647) * When the single-turn absolute function is effective (Pr0.15=3), refer to Technical Reference Function Specification “Section 6-6”	-
<Response_Data1> Actual_Position (APOS)	-	Default: Actual position of motor [Size]: Signed 32-bit [Unit]: Instruction unit

- For selection method of Response_Data 1, see 4-3-1.

5-4 Cyclic position control (CP) command (Command code: 2□h)

In this position control mode, the host controller generates the position command and updates it (or transmits updated command) at the command updating cycle.

For the operation command update (transmission), input when approx. 100 ms has elapsed after the servo ON.

Upon receiving this command, the servo driver switches the internal control mode to the position control.

For detailed block diagram of the position control, refer to Technical Reference Functional Specification “Section 5-2-1”.

Position control shall be made using external scale under full-closed control.

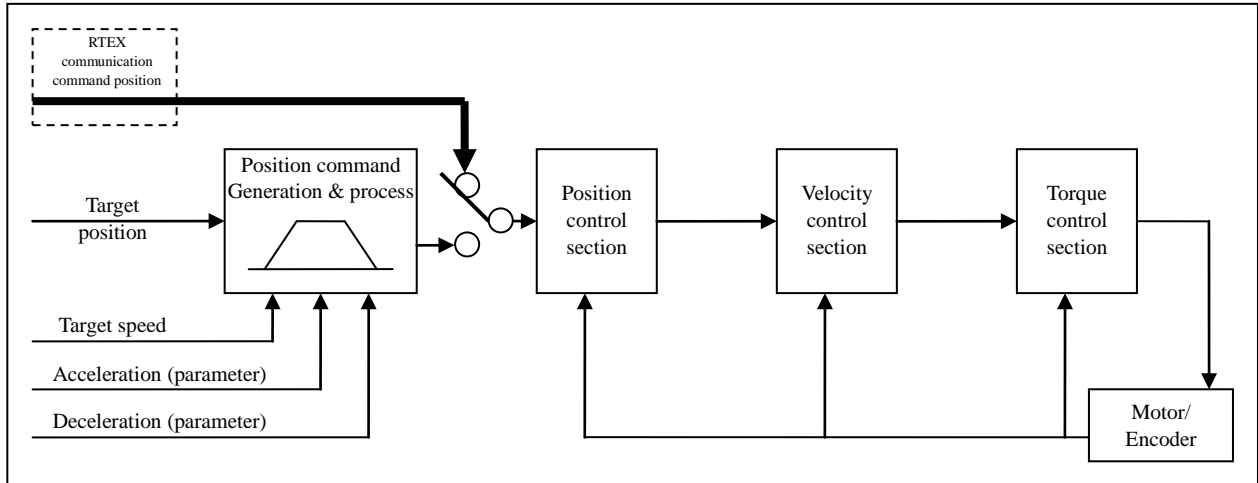

	Byte	Command								Byte	Response									
		bit7	6	5	4	3	2	1	0		bit7	6	5	4	3	2	1	0		
Cyclic	0	C (0)	Update_Counter		MAC-ID						0	R (1)	Update_Counter_Echo		Actual_MAC-ID					
	1	TMG_CNT	Command_Code (2□h)								1	CMD_Error	Command_Code_Echo (2□h)							
	2	Control_Bits								2	Status_Flags									
	3																			
	4	<Command_Data1> Target_Position (CMD_POS) [Command unit]								L	<Response_Data1> Default: Actual_Position (APOS) [Command unit]								L	
	5									ML									5	ML
	6									MH									6	MH
7	H									7									H	
Non-cyclic	8	<Command_Data2> Dependent on non-cyclic command								L	<Response_Data2> Dependent on non-cyclic command								L	
	9									ML									9	ML
	10									MH									10	MH
	11									H									11	H
	12									L									12	L
	13									ML									13	ML
	14									MH									14	MH
15	H	15	H																	

Title	Command	Response
<Command_Data1> Target_Position (TPOS)	Target position (absolute position) [Size]: Signed 32-bit [Unit]: Instruction unit [Setting range]: 8000000h-7FFFFFFh (-2147483648 to 2147483647) * When the single-turn absolute function is effective (Pr0.15=3), refer to Technical Reference Function Specification “Section 6-6”	-
<Response_Data1> Actual_Position (APOS)	-	Default: Actual position of motor [Size]: Signed 32-bit [Unit]: Instruction unit

- For selection method of Response_Data 1, see 4-3-1.

5-5 Cyclic velocity control (CV) command (Command code: 3□h)

In this velocity control mode, the host controller generates the command velocity and updates it (or transmits updated command) at the communication cycle.

For the operation command update (transmission), input when approx. 100 ms has elapsed after the servo ON.

Upon receiving this command, the servo driver switches the internal control mode to velocity control.

For details of velocity control block diagram, refer to Technical Reference Functional Specification “Section 5-2-2”.

Command error will occur, when this command is received under full-closed control or two degree-of-freedom control (synchronous) mode.

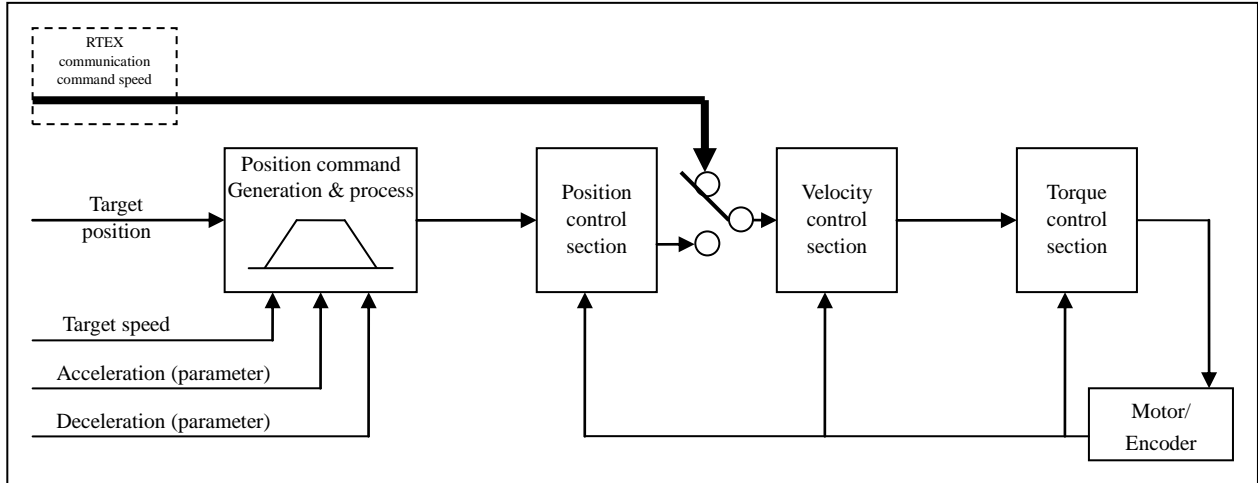

	Byte	Command								Byte	Response																
		bit7	6	5	4	3	2	1	0		bit7	6	5	4	3	2	1	0									
Cyclic	0	C (0)	Update_Counter		MAC-ID				0	R (1)	Update_Counter_Echo		Actual_MAC-ID														
	1	TMG_CNT	Command_Code (3□h)								1	CMD_Error	Command_Code_Echo (3□h)														
	2	Control_Bits								2	Status_Flags																
	3																										
	4	<Command_Data1> Target_Position (CSPD) [Command unit/s] or [r/min]								L	4	<Response_Data1> Default: Actual_Position (APOS) [Command unit]															
	5									ML	5																
	6									MH	6																
7	H									7																	
Non-cyclic	8	<Command_Data2> Dependent on non-cyclic command								L	8	<Response_Data2> Dependent on non-cyclic command															
	9									ML	9																
	10									MH	10																
	11									H	11																
	12									L	12									<Response_Data3> Dependent on non-cyclic command							
	13									ML	13																
	14									MH	14																
15	H	15																									

Title	Command	Response						
<Command_Data1> Command_Speed (CSPD)	Instruction speed [Size]: Signed 32-bit [Unit]: Setting value of Pr.7.25 “RTEX speed unit setup” <table border="1" style="margin-left: 20px;"> <thead> <tr> <th>Pr.7.25</th> <th>Unit</th> </tr> </thead> <tbody> <tr> <td>0</td> <td>[r/min]</td> </tr> <tr> <td>1</td> <td>[Command unit/s]</td> </tr> </tbody> </table> [Setting range]: - motor maximum speed to motor maximum speed * When speed setting is in r/min, it is converted to command unit/s through internal computation and the equivalent value is limited within the range as shown below: -8000001h~7FFFFFFFh (-2147483647~2147483647)	Pr.7.25	Unit	0	[r/min]	1	[Command unit/s]	-
Pr.7.25	Unit							
0	[r/min]							
1	[Command unit/s]							
<Response_Data1> Actual_Position (APOS)	-	Default: Actual position of motor [Size]: Signed 32-bit [Unit]: Command unit						

▪ For selection method of Response_Data 1, see 4-3-1.

5-6 Cyclic torque control (CT) command (Command code: 4□h)

In this torque control mode, the host controller generates the command torque and updates it (or transmits updated command) at the communication cycle.

For the operation command update (transmission), input when approx. 100 ms has elapsed after the servo ON.

Upon receiving this command, the servo driver switches the internal control mode to torque control.

For detailed torque control block diagram, refer to Technical Reference Functional Specification “Section 5-2-3”.

Command error will occur, when this command is received under full-closed control or two degree-of-freedom control (standard/synchronous) mode.

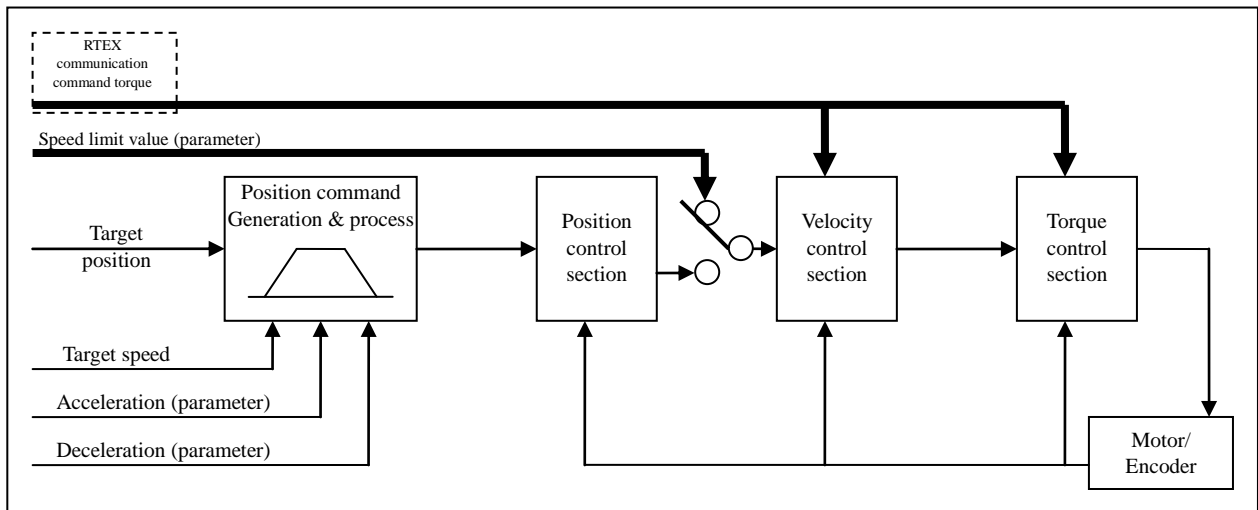

	Byte	Command								Byte	Response									
		bit7	6	5	4	3	2	1	0		bit7	6	5	4	3	2	1	0		
Cyclic	0	C (0)	Update_Counter		MAC-ID				0	R (1)	Update_Counter_Echo		Actual_MAC-ID							
	1	TMG_CNT	Command_Code (4□h)								1	CMD_Error	Command_Code_Echo (4□h)							
	2	Control_Bits								2	Status_Flags									
	3									3										
	4	<Command_Data1>								L	4									
	5	Command_Torque (CTRQ)								ML	5									
	6	[0.1%]								MH	6									
Non-Cyclic	7									H	7									
	8	<Command_Data2>								L	8									
	9	Dependent on non-cyclic command								ML	9									
	10									MH	10									
	11									H	11									
	12	<Command_Data3>								L	12									
	13	Dependent on non-cyclic command								ML	13									
14									MH	14										
15									H	15										

Title	Command	Response
<Command_Data1> Command_Torque (CTRQ)	Instruction speed [Size]: Signed 32-bit [Unit]: 0.1% [Setting range]: - motor maximum torque to motor maximum torque	-
<Response_Data1> Actual_Position (APOS)	-	Default: Actual position of motor [Size]: Signed 32-bit [Unit]: Command unit

- For selection method of Response_Data 1, see 4-3-1.

6. Non-cyclic Command Description

6-1 Non-cyclic command list

Non-cyclic commands such as parameter set up are event driven type command.

For details of transmission protocol, refer to Chapter 3.

For details of operation, refer to 6-2 and subsequent sections.

Non-cyclic command code	Title	Description	Supporting sub-command	Cyclic command (correspondence relation with □ shown under "non-cyclic command code")				
				NOP (0h)	PP (1h)	CP (2h)	CV (3h)	CT (4h)
□0h	Normal	Use this command for normal operation. This command is reference non-cyclic command.	○	○	○	○	○	○
□1h	Reset	Use this command to reset the servo driver, or to enable attribute C parameter without resetting the servo driver.	-	▲	○	○	○	○
□2h	System ID	Use this command to read the system ID of the servo driver. Information specified by Type_Code and Index will be returned in ASCII code.	○	▲	○	○	○	○
□4h	Return to home	Use this command to start return to home operation, to latch position information etc.	-	-	△	○	△	△
□5h	Alarm	Use this to read an alarm code, to clear the current alarm etc.	-	-	○	○	○	○
□6h	Parameter	Use this to read out or write parameter, to write to EEPROM etc.	-	-	○	○	○	○
□7h	Profile	Use this to start operation in the profile position control mode (PP).	-	-	○	-	-	-
□Ah	Monitor	Use this to monitor position error, loading factor, etc.	○	-	○	○	○	○
-	Command error	Response is returned if the servo driver cannot receive an incomplete command, or Byte 1, bit 7 is 1.	-	-	-	-	-	-
(FFh) Response only	Communication error	The servo driver will send this response as it detects communication error (CRC error). Upon detecting the CRC error, servo driver will use the previously received command for controlling. (During CP controlling, command position is controlled using estimated position.)	-	-	-	-	-	-

▪ ○: Supported; △: Partially supported; ▲: Supported by the manufacturer (for specific applications only); -: Not supported

6-2 Normal command (Command code: □0h)

Command used for normal operation.

This command is also reference command of non-cyclic command.

Compatible control mode				
NOP	PP	CP	CV	CT
○	○	○	○	○

■ Main command: Common to 16 byte and 32 byte mode

Byte	Command								Byte	Response							
	bit7	6	5	4	3	2	1	0		bit7	6	5	4	3	2	1	0
0	C (0)	Update_Counter		MAC-ID					0	R (1)	Update_Counter_Echo		Actual_MAC-ID				
1	TMG_CNT	Command_Code (□0h)							1	CMD_Error	Command_Code_Echo (□0h)						
2	Control_Bits								2	Status_Flags							
3									3								
4								L	4								L
5	Command_Data1							ML	5	Response_Data1							ML
6								MH	6								MH
7								H	7								H
8								L	8								L
9	Command_Data2							ML	9	Response_Data2							ML
10								MH	10								MH
11								H	11								H
12								L	12								L
13	Command_Data3							ML	13	Response_Data3							ML
14								MH	14								MH
15								H	15								H

■ Sub-command: Only for 32 byte mode

Byte	Command								Byte	Response							
	bit7	6	5	4	3	2	1	0		bit7	6	5	4	3	2	1	0
16	Sub_Chk (1)	0	0	0	Sub_Command_Code (0h)				16	Sub_CMD_Err	Sub_ERR	Sub_WNG	Sub_Busy	Sub_Command_Code_Echo (0h)			
17	Sub_Type_Code								17	Sub_Type_Code_Echo							
18								L	18	Sub_Index_Echo							L
19	Sub_Index							H	19								H
20								L	20								L
21	Sub_Command_Data1							ML	21	Sub_Response_Data1							ML
22								MH	22								MH
23								H	23								H
24								L	24								L
25	Sub_Command_Data2							ML	25	Sub_Response_Data2							ML
26								MH	26								MH
27								H	27								H
28								L	28								L
29	Sub_Command_Data3							ML	29	Sub_Response_Data3							ML
30								MH	30								MH
31								H	31								H

Title	Command	Response
Command_Data2 /Response_Data2	Optional	Data specified by Pr.7.30 "RTEX monitor select 2"
Command_Data3 /Response_Data3	Data specified by Pr.7.35 "RTEX command setting 1" ▪ For details, refer to Sections 7-7-1.	Data specified by Pr.7.31 "RTEX monitor select 3"
Sub_Type_Code	Optional	—
Sub_Index	Optional	—
Sub_Command_Data1 /Sub_Response_Data1	Optional	Data specified by Pr.7.32 "RTEX monitor select 4"

6-3 Reset Command (Command code: □1h)

Use this command to reset the servo driver, or to enable attribute C parameter without resetting the servo driver.

Compatible control mode				
NOP	PP	CP	CV	CT
▲	○	○	○	○

<Precautions>
 Before starting the reset command assure the safety: make sure that servo is off and apply brake to the motor as necessary.

■ Main command: Common to 16 byte and 32 byte mode

	Byte	Command								Byte	Response								
		bit7	6	5	4	3	2	1	0		bit7	6	5	4	3	2	1	0	
Cyclic	0	C (0)	Update_Counter		MAC-ID					0	R (1)	Update_Counter_Echo		Actual_MAC-ID					
	1	TMG_CNT	□1h							1	CMD_Error	□1h							
	2	Control_Bits								2	Status_Flags								
	3									3									
	4									L	4								
	5	Command_Data1								ML	5	Response_Data1							
	6									MH	6								
Non-cyclic	7									H	7								
	8	Type_Code								L	8	Type_Code_Echo							
	9	0								H	9	ERR	WNG	0	Busy				
	10	Index								L	10	Index_Echo							
	11	(0)								H	11	(0)							
	12									L	12								
	13	Command_Data3								ML	13	Monitor_Data							
14									MH	14	(0)								
15									H	15									

■ Sub-command: Only for 32 byte mode

Reset command does not support the sub-command.

Title	Command	Response						
Type_Code /Type_Code_Echo	Reset mode setup <table border="1" style="margin-left: 20px;"> <thead> <tr> <th>Setting value</th> <th>Description</th> </tr> </thead> <tbody> <tr> <td>001h</td> <td>Software reset mode</td> </tr> <tr> <td>011h</td> <td>Attribute C parameter validation mode</td> </tr> </tbody> </table> ▪ For details, refer to Sections 6-3-1 and 6-3-2.	Setting value	Description	001h	Software reset mode	011h	Attribute C parameter validation mode	Type_Code echo back value.
Setting value	Description							
001h	Software reset mode							
011h	Attribute C parameter validation mode							
Index /Index_Echo	Set to 0	Return 0						
Command_Data3 /Monitor_Data	Data specified by Pr.7.35 "RTEX command setting 1" ▪ For details, refer to Sections 7-7-1.	Return 0						

6-3-1 Software reset mode (Type_Code: 001h)

Use this mode when resetting (restarting) servo driver without turning off control power (software resetting).

Reset process has to be executed after confirming that the all of servo drivers have received reset command (□1h) normally, because it is necessary to reset surely all servo drivers even if the communication error occurs.

For this purpose, the servo driver resets itself at transition from the reset command (□1h) to normal command (□0h).

If the communication error occurs at transition from the reset command to normal command, there might be case that only some of the drivers can receive the normal command. In this case, the servo driver also resets itself if the communication time-out has occurred in the condition that the last command was Reset command (□1h).

The following shows the procedures to reset servo drivers.

- 1) Change command code of all servo drivers from normal command (□0h) to Reset command (□1h). Also, be sure to set Type_Code to 001h and Index and Setting_Data to 0.
- 2) Confirm that the value of Command Code Echo sent from all servo drivers is (□1h), and then return to normal command (□0h).
- 3) The servo driver will start executing a reset process when normal command (□0h) has been received normally, or when the communication time-out has occurred in the condition that the last received command was Reset command (□1h).
- 4) Since there is no response from servo drivers due to the reset state, the master will detect the communication time-out. When the time-out is detected, reset the RTEX communication IC and initialize the communication again.

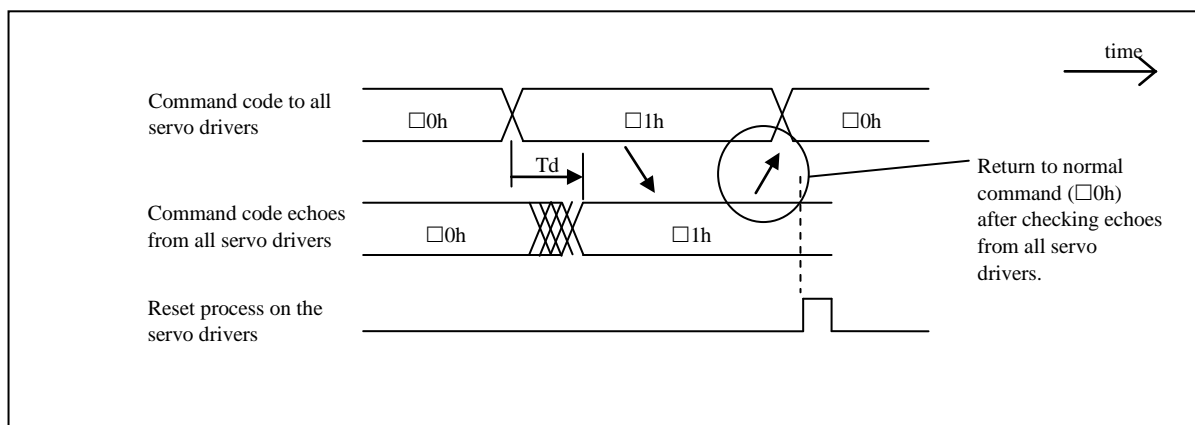

Note: During resetting process, output signal (output transistor) is OFF.

6-3-2 Attribute C parameter validation mode (Type_Code: 011h)

Use this mode when validating the changed parameter of attribute C after establishing communication without turning off control power or resetting (software reset) servo driver.

When validating attribute C, it is not necessary to write this parameter to EEPROM before executing the command (prewriting is optional).

Because the parameter of attribute R becomes effective only after resetting, it is not made effective by this command. Reset the control power source or perform software reset (Type_Code = 001h). In this case, it is necessary to write the parameter to EEPROM beforehand.

For attribution of a specific parameter, refer to Technical Reference Functional Specification “Section 9-1”.

- When this command is received in servo-on status, it causes the command error (0045h).
While processing the command, keep servo-off status. When servo is turned on (Servo_On = 1) during processing of this command, Err. 27.7 “Position information initialization error protection” will occur.
- A command error (005Bh) will occur if this command is received during virtual full-closed control mode state.
- A command error (005Bh) will occur if a command to switch to virtual full-closed control mode is received during execution of this command.
- While executing this command, maintain this command and command argument (e.g. Type_Code).
- After execution of the command, all position information including actual position is initialized.
This means that return to home is not completed (provided not in absolute mode) and latch is not completed.
After successful completion of the command, repeat the return to home. Status and output signals during command execution are as shown below.

Status/output signal	Before execution	Executing	After execution
Position information	Current position information	Initialization	Information on the current position with reference to initialized position *1)
Return to home status	Current status	Undefined	<ul style="list-style-type: none"> • Unfinished while incrementing • Finished in absolute mode
Latch status	Current status	Undefined	Unfinished
Busy (non-cyclic status)	0	1	0
Other status	Current status	Undefined	Current status
Output signal	Current status	Undefined	Current status

*1) Information on position after initialization

<Incremental mode> All position information = 0

<Absolute mode> All position information = Value of absolute encoder (scale)/electronic gear ratio + Pr.7.13 “Absolute home position offset”

- While executing the command, do not run the setup support software PANATERM.

6-4 System ID Command (Command code: □2h)

Use this when you read out the system ID of the servo driver.
Return the information specified by Type_Code and Index in ASCII code.

Compatible control mode				
NOP	PP	CP	CV	CT
▲	○	○	○	○

■ Main command: Common to 16 byte and 32 byte mode

Byte	Command								Byte	Response								
	bit7	6	5	4	3	2	1	0		bit7	6	5	4	3	2	1	0	
0	C (0)	Update_Counter		MAC-ID					0	R (1)	Update_Counter_Echo		Actual_MAC-ID					
1	TMG_CNT	□2h							1	CMD_Error	□2h							
2	Control_Bits								2	Status_Flags								
3									3									
4									L	4								
5	Command_Data1								ML	5	Response_Data1							
6									MH	6								
7									H	7								
8	Type_Code								L	8	Type_Code_Echo							
9	0								H	9	ERR	WNG	0	Busy				H
10	Index								L	10	Index_Echo							
11									H	11								
12									L	12								
13	Command_Data3								ML	13	Monitor_Data							
14									MH	14	(ASCII code)							
15									H	15								

■ Sub-command: Only for 32 byte mode

Byte	Command								Byte	Response								
	bit7	6	5	4	3	2	1	0		bit7	6	5	4	3	2	1	0	
16	Sub_Chk (1)	0	0	0	Sub_Command_Code (2h)				16	Sub_CMD_Err	Sub_ERR	Sub_WNG	Sub_Busy	Sub_Command_Code_Echo (2h)				
17	Sub_Type_Code								17	Sub_Type_Code_Echo								
18	Sub_Index								L	18	Sub_Index_Echo							
19									H	19								
20									L	20								
21	Sub_Command_Data1								ML	21	Sub_Monitor_Data							
22									MH	22	(ASCII code)							
23									H	23								
24									L	24								
25	Sub_Command_Data2								ML	25	Sub_Response_Data2							
26									MH	26								
27									H	27								
28									L	28								
29	Sub_Command_Data3								ML	29	Sub_Response_Data3							
30									MH	30								
31									H	31								

Title	Command	Response										
Type_Code /Type_Code_Echo	Specify the system ID to be read. ▪ For details, refer Section 6-4-1.	Type_Code echo back value										
Sub_Type_Code /Sub_Type_Code_Echo												
Index/Index_Echo		Index echo back value										
Sub_Index /Sub_Index_Echo												
Command_Data3 /Monitor_Data	Data specified by Pr.7.35 “RTEX command setting 1” ▪ For details, refer to Sections 7-7-1.	<table border="1"> <thead> <tr> <th>Byte</th> <th>Read out value (ASCII code)</th> </tr> </thead> <tbody> <tr> <td>12</td> <td>(4 x Index) ASCII code</td> </tr> <tr> <td>13</td> <td>(4 x Index + 1) ASCII code</td> </tr> <tr> <td>14</td> <td>(4 x Index + 2) ASCII code</td> </tr> <tr> <td>15</td> <td>(4 x Index + 3) ASCII code</td> </tr> </tbody> </table>	Byte	Read out value (ASCII code)	12	(4 x Index) ASCII code	13	(4 x Index + 1) ASCII code	14	(4 x Index + 2) ASCII code	15	(4 x Index + 3) ASCII code
Byte	Read out value (ASCII code)											
12	(4 x Index) ASCII code											
13	(4 x Index + 1) ASCII code											
14	(4 x Index + 2) ASCII code											
15	(4 x Index + 3) ASCII code											
Sub_Command_Data1 /Sub_Moniroit_Data	Set to 0											

6-4-1 System ID command Type_Code list

Type_Code *1) *4)		Designation	Description																														
A4N compatible	standard																																
010h	01h	Vendor name	“Panasonic”																														
050h	05h	Device type	Read out the device type. Example: “1” Servo driver (rotary motor)																														
060h	06h	Manufacturer use	-																														
120h	12h	Driver model No.	Read out the model number of the servo driver. *3) Example: “MADLN15NE”																														
130h	13h	Driver serial No.	Read out the serial number of the servo driver. * In versions corresponding to function extended edition 4 or later, the range of readable serial number has been expanded, and it's supported even if lower 4 characters contain alphabets.																														
140h	14h	Servo driver software version	Read out the firmware version of the servo driver. Read the CPU1 version from the 1st to 4th characters. Read the CPU2 version from the 6th to 9th characters. Example: “1.04_1.01”																														
150h	15h	Driver type	Read out the type of servo driver. Use this command to check the series of the servo driver and functions supported by the servo driver.																														
220h	22h	Motor model No.	Read out the model number of the servo motor which is connected to the servo driver. Example: “MSMF022L1A1”																														
230h	23h	Motor serial No.	Read out the serial number of the servo motor which is connected to the servo driver. Example: “17040021” * In versions corresponding to function extended edition 4 or later, the range of readable serial number has been expanded, and it's supported even if lower 4 characters contain alphabets.																														
310h	31h	External scale vendor ID *2)	Reads external scale vendor ID and model ID. Example																														
320h	32h	External scale model ID *2)	<table border="1"> <thead> <tr> <th colspan="2">Vendor ID</th> <th colspan="2">Model ID</th> </tr> <tr> <th></th> <th>Vendor</th> <th></th> <th>Absolute/Incremental</th> </tr> </thead> <tbody> <tr> <td rowspan="3">‘3’</td> <td rowspan="3">Mitutoyo Corp.</td> <td>‘1’</td> <td>Absolute</td> </tr> <tr> <td>‘2’</td> <td>Absolute (Electromagnetic induction type)</td> </tr> <tr> <td>‘3’</td> <td>Incremental</td> </tr> <tr> <td rowspan="3">‘4’</td> <td rowspan="3">Magnescale Co., Ltd.</td> <td>‘1’</td> <td>Absolute</td> </tr> <tr> <td>‘2’</td> <td>Incremental</td> </tr> <tr> <td>‘3’</td> <td>Laser scale</td> </tr> <tr> <td rowspan="2">‘5’</td> <td rowspan="2">Common ID (Panasonic communication spec.)</td> <td>‘1’</td> <td>Absolute</td> </tr> <tr> <td>‘2’</td> <td>Incremental</td> </tr> </tbody> </table>	Vendor ID		Model ID			Vendor		Absolute/Incremental	‘3’	Mitutoyo Corp.	‘1’	Absolute	‘2’	Absolute (Electromagnetic induction type)	‘3’	Incremental	‘4’	Magnescale Co., Ltd.	‘1’	Absolute	‘2’	Incremental	‘3’	Laser scale	‘5’	Common ID (Panasonic communication spec.)	‘1’	Absolute	‘2’	Incremental
Vendor ID		Model ID																															
	Vendor		Absolute/Incremental																														
‘3’	Mitutoyo Corp.	‘1’	Absolute																														
		‘2’	Absolute (Electromagnetic induction type)																														
		‘3’	Incremental																														
‘4’	Magnescale Co., Ltd.	‘1’	Absolute																														
		‘2’	Incremental																														
		‘3’	Laser scale																														
‘5’	Common ID (Panasonic communication spec.)	‘1’	Absolute																														
		‘2’	Incremental																														
340h	34h	Manufacturer use	-																														

*1) Command Error (0031h) will be returned at setting up the wrong Type Code.

*2) Returns 0 (null) for external scale vendor ID and model ID in the following cases:

- When external scale position information monitor function is invalid under semi-closed control mode.
- In case of AB phase output type and is not serial communication type.

It will return “0” in case of the following:

- When it has failed to read data from the external scale.

*3) The 4th character in the model number also represents the series of the servo driver.

Series	4th character in the model number
MINAS-A4N	D
MINAS-A5N	H
MINAS-A6N	L

*4) A4N compatible Type_Code: compatible with that for A4N and can be used only with main command.

standard Type_Code: Prepared for A5N, A6N and can be used with both main command and subcommand.
When using with main command, set upper 4-bit to 0.

* Although the product supports A4N-compatible Type_Code to maintain compatibility, basically use the standard Type_Code.

6-4-2 Example of reading of vendor name (“Panasonic”)

Byte		1st	2nd	3rd
8	Type_Code_Echo	01h	01h	01h
9				
10	Index_Echo	0	1	2
11				
12	ASCII code	‘P’	‘s’	‘c’
13	ASCII code	‘a’	‘o’	0 (NULL) *1)
14	ASCII code	‘n’	‘n’	0 (NULL) *1)
15	ASCII code	‘a’	‘i’	0 (NULL) *1)

*1) The servo driver will return 0 (NULL) at the end of the character string.

6-4-3 Device type

Device type is identified as follows:

With this servo driver, “1” will be returned.

Device type	Description
‘0’	(Reserved)
‘1’	Servo driver
‘2’	Stepping
‘3’	Pulse OUT
‘4’	Digital IN
‘5’	Digital OUT or IN & OUT
‘6’	Analog IN
‘7’	Analog OUT or IN & OUT
‘8’	(Reserved)
‘9’	Gateway
‘A’-‘F’	(Reserved)
‘10’	(Reserved)
‘11’	(Reserved)

Note: Conventional MINAS-A4N does not support the device type.

6-4-4 Servo driver software version

Example of read in the case of CPU1: Ver1.04, CPU2: Ver1.01

The data to be obtained is "1.04_1.01".

Byte		1st	2nd	3rd
8	Type_Code_Echo	14h	14h	14h
9				
10	Index_Echo	0	1	2
11				
12	ASCII code	'1'	'_'	'1'
13	ASCII code	'.'	'1'	0 (NULL) *1)
14	ASCII code	'0'	'.'	0 (NULL) *1)
15	ASCII code	'4'	'0'	0 (NULL) *1)

*1) The servo driver will return 0 (NULL) at the end of the character string.

6-4-5 Servo driver type

Driver type is identified as follows:

Rotary type driver of MINAS-A6N series of the standard specification will response as shown below.

Index 0 Byte12 = '2'

Byte13 = '0'

Byte14 = '1'

Byte15 = '1'

Index 1 Byte12 = '1'

Byte13 = '1'

Index	0				1				2	3	4 and subsequent	
	12	13	14	15	12	13	14	15	12-15	12-15	12-15	
Series/function	Driver series	Type of motor connected	CP control	CV control	CT control	PP control	(Reserved)	(Reserved)	(Reserved)	(Reserved)	-	
Servo driver type	'0'	A4N	Rotary type	Unsupported	Unsupported	Unsupported	Unsupported	(Reserved)	(Reserved)	(Reserved)	(Reserved)	0 (NULL) *1)
	'1'	A5N	Linear type	Supported	Supported	Supported	Supported					
	'2'	A6N	(Reserved)	(Reserved)	(Reserved)	(Reserved)	(Reserved)					
	Other	(Reserved)	(Reserved)	(Reserved)	(Reserved)	(Reserved)	(Reserved)					

*1) Returned 0 (NULL) indicates the end of character string.

Note: Conventional MINAS-A4N does not support the servo driver type.

6-5 Homing command (Command code: □4h)

Use this command when performing homing, latching actual position, etc.

Compatible control mode				
NOP	PP	CP	CV	CT
-	△	○	△	△

For details of return to home operation, refer to Section 7-2.

■ Main command: Common to 16 byte and 32 byte mode

Byte		Command								Byte		Response							
bit7		6	5	4	3	2	1	0	bit7		6	5	4	3	2	1	0		
0	C (0)	Update_Counter		MAC-ID				0		R (1)	Update_Counter_Echo		Actual_MAC-ID						
1	TMG_CNT	□4h								1	CMD_Error	□4h							
2	Control_Bits								2	Status_Flags									
3									3										
4	Command_Data1								L	4	Response_Data1								L
5									ML	5									ML
6									MH	6									MH
7									H	7									H
8	Type_Code								8	Type_Code_Echo									
9	0								9	ERR	WNG	0	Busy	0	0	Latch_Comp2	Latch_Comp1		
10	Latch_Sel2				Latch_Sel1				10	Latch_Sel2_Echo				Latch_Sel1_Echo					
11	Monitor_Sel								11	Monitor_Sel_Echo									
12	Setting_Data								L	12	Monitor_Data								L
13	(Command_Data3)								ML	13									ML
14									MH	14									MH
15									H	15									H

■ Sub-command: Only for 32 byte mode

Homing command does not support the sub-command.

Title	Command	Response
Type_Code /Type_Code_Echo	Type of return-to-home ▪ For detailed description, refer to Section 6-5-1.	Type_Code echo back value
Latch_Comp1, Latch_Comp2	-	Latch position 1/2 complete state ▪ For detailed description, refer to Section 6-5-4.
Latch_Sel1, Latch_Sel2, /Latch_Sel1_Echo, Latch_Sel2_Echo,	<In latch mode, latch mode with stop function> Selection of position latch 1 (Ch1) or position latch 2 (Ch2) trigger signal ▪ For detailed description, refer to Section 6-5-4, 6-5-5. <Mode other than latch, latch mode with stop function> Set to 0.	<In latch mode, latch mode with stop function> Latch_Sel1, Latch_Sel2 echo back value ▪ For detailed description, refer to Section 6-5-4, 6-5-5. <Mode other than latch, latch mode with stop function> Latch_Sel1, Latch_Sel2 (= 0) echo back value
Monitor_Sel /Monitor_Sel_Echo	<In latch mode, latch mode with stop function > Selection of data to be returned to Monitor_Data ▪ For detailed description, refer to Section 6-5-4, 6-5-5. <Mode other than latch, latch mode with stop function> Set to 0.	<In latch mode, latch mode with stop function> Selection of data to be returned to Monitor_Data ▪ For detailed description, refer to Section 6-5-4, 6-5-5. <Mode other than latch, latch mode with stop function> Monitor_Sel(=0) echo back value
Setting_Data (Command_Data3) /Monitor_Data	<Actual position setup and command position setup> Actual position setting value and command position setting value [Size]: Signed 32-bit [Unit]: Instruction unit [Setting range]: 80000000h~7FFFFFFFh (-2147483648 to 2147483647) * For versions corresponding to function extended version 3 or earlier, set up so that product of Setting_Data × electronic gear ratio is -2 ³⁰ to 2 ³⁰ -1. * When the single-turn absolute function is effective (Pr0.15=3), refer to Technical Reference Function Specification "Section 6-6", <Non-actual position setup and Non-command position setup> Data specified by Pr.7.35 "RTEX command setting 1" ▪ For details, refer to Sections 7-7-1.	<Actual position setup/command position setup> Echo back of actual position setting value/command position setting value [Size]: Signed 32-bit [Unit]: Instruction unit <In latch mode, latch mode with stop function> Monitor data selected through Monitor_Sel ▪ For detailed description, refer to Section 6-5-4, 6-5-5. <When not in actual position setup, command position setup, latch mode or latch mode with stop function > Return 0

6-5-1 Type Code list of Homing Command

Position information with/without initialization	Type Code *1) *6)	Type of return-to-home (reference trigger)	Pr.0.01(Control mode setup)														Servo-on status		Homing_Ctrl bit used/unused
			0: Semi-closed								6: Full-closed								
			Profile position control (PP)		Cyclic position control (CP)		Cyclic velocity control (CV)		Cyclic torque control (CT)		Profile position control (PP)			Cyclic position control (CP)			ON	OFF	
			SER ABS	SER ABS	SER ABS	SER ABS	SER ABS	SER ABS	SER INC	ABZ INC	SER ABS	SER INC	ABZ INC	SER ABS					
INC	ABS	INC	ABS	INC	ABS	INC	ABS	INC	ABS	INC	ABS	INC	ABS						
[With] Initialization mode	11h	Z- phase	—	—	○	—	—	—	—	—	—	—	—	○	○	—	○	—	Used
	12h	HOME↑ *2)																	
	13h	HOME↓ *3)																	
	14h	POT↑ *2)																	
	15h	POT↓ *3)																	
	16h	NOT↑ *2)																	
	17h	NOT↓ *3)																	
	18h	EXT1↑ *2)	—	—	○	—	—	—	—	—	—	—	—	○	○	—	○	—	
	19h	EXT1↓ *3)																	
	1Ah	EXT2↑ *2)																	
	1Bh	EXT2↓ *3)																	
	1Ch	EXT3↑ *2)																	
	1Dh	EXT3↓ *3)																	
	[Without] Latch mode	21h	Actual position set	○	—	○	—	—	—	—	—	○	○	—	○	○	—	○	
22h		Command position set																	
31h		Clear multi-turn data of absolute encoder *5)	—	○	—	○	—	○	—	○	—	—	—	—	—	—	—	○	
[Without] Latch mode	50h	Position latch Status monitor																	Unused
	51h	Position latch 1 Start																	
	52h	Position latch 2 Start																	
	53h	Position latch 1, 2 Start	○	○	○	○	○	○	○	○	○	○	△ *4)	○	○	△ *4)	○	○	
	54h	Position latch 1 Cancel																	
	58h	Position latch 2 Cancel																	
	5Ch	Position latch 1, 2 Cancel																	
[Without] Latch mode with stop function	F1h	Position latch 1 Start with stop function	—	—	○	○	—	—	—	—	—	—	—	○	○	○	○	—	Unused

○: Supported; △: Partially supported; -: Not supported

*1) Command error (0031h) will be returned at setting up the wrong type code.

*2) [↑]: Logical rising edge of external input signal (off → on timing of internal processing)

*3) [↓]: Logical falling edge of external input signal (on → off timing of internal processing)

*4) As there is no Z-phase in serial communication type absolute external scale, Z-phase cannot be set as the latch trigger. Command error (005Ah) is returned in this case.

- *5) If multi-turn clearing of the absolute encoder has been executed when the single-turn absolute function is effective, command error (0051h) will be returned.
- *6) In semi-closed control, external scale position information when external scale position information monitor function is effective is not initialized despite returning to home.

Terms in table in the previous page	Semi-closed	Full-closed
SER_INC	—	Serial communication type Incremental external scale
ABZ_INC	—	Output type of A, B and Z phases Incremental external scale
SER_ABS	23-bit absolute encoder	Serial communication type Absolute external scale
INC	Incremental mode	—
ABS	Absolute mode	—

Example: When Type_Code = 18h

- Semi-closed position control (CP) and SER_INC
Or full-closed position control (CP), and SER_INC or ABZ_INC
 - Servo on status
 - Homing_Ctrl bit is 1
 - Initialization to clear position information (actual position/internal command position) to 0 at the timing logical level of EXT1 signal rises from 0 → 1.
 - Internal process includes position correction during arithmetic process (sampling).
- Profile absolute positioning/relative positioning, actual position setup during continuous rotation (In_Progress = 1) and command position setup will be possible but it will cancel PP operation. Performing Type_Code = 1□h, 31h will cause Err.91.1 “RTEX command error protection” and command error (0059h). The latch mode can be started during PP operation.
 - During profile position latch absolute positioning/relative positioning and profile homing 1 to 4,6 these processes overlap. Therefore, do not use this command (any Type_Code). Otherwise, Err.91.1 “RTEX command error protection”, command error (0059h) will occur.
 - Perform the clear multi-turn data of absolute encoder while maintaining servo-off condition. If servo is on, command error (0056h) will occur.
 - For other possible causes of error, refer to 6-10-2.
 - Homing_Ctrl bit is not used for control of Actual position setting, Command position setting and clearing of multi-turn data of absolute encoder.
 - When Type_Code is 5□h, the position information is not initialized and the actual position is latched as the trigger is detected.
 - Edge will be detected in logic level of the signal, and not physical level.
 - In full closed control mode, return to origin will be made, not on the Z-phase of the encoder, but on the Z-phase of the external scale as the reference position.
 - When POT/NOT is the home position reference trigger, be sure to set Pr.5.04 “Over-travel inhibit input setup” to 1, to disable the over-travel inhibit input. Otherwise, Err. 38.2 “Drive inhibit input protection 3” will occur.
 - For precautions on assignment of external signal associated with the return-to-home sequence, refer to Section 6-5-2.
 - When the position information is initialized, the latched status is changed to unlatched status.

- If return to origin command cancellation is executed by the host device after detecting the origin before return to the origin is completed in return to origin command (Type_Code: 11h to 1Dh), an alarm which cannot be cleared Err27.7 “Position information initialization error protection” will occur.
 - * This is a specification for function extended version 4.
- A command error (005Bh) will occur if this command is received during virtual full-closed control mode state.
- A command error (005Bh) will occur if a command to switch to virtual full-closed control mode is received during execution of return to origin command (Type_Code: 11h to 1Dh, F1h).
- A command error (005Bh) will occur if a command to switch to virtual full-closed control mode is received during the period from latch startup to latch detection when the system is switched to a code other than command code (□4h) after starting return to origin command (Type_Code: 51h to 53h).
Switching to virtual full-closed control mode is possible after latch detection.

6-5-2 Assignment of external input signals related to return to home sequence

When allocating the return-to-home related external inputs (HOME, POT, NOT, EXT1, EXT2 and EXT3) to the internal terminals, note the following:

- 1) EXT1 can be allocated only to SI5, EXT2 only to SI6 and EXT3 only to SI7.
- 2) When using HOME, POT and NOT as home position reference trigger, HOME can be allocated only to SI5, POT only to SI6 and NOT only to SI7.
- 3) When allocating EXT1, EXT2, EXT3, HOME, POT or NOT to latch correction terminal (SI5, SI6 or SI7), allocate the same signal in all control modes.

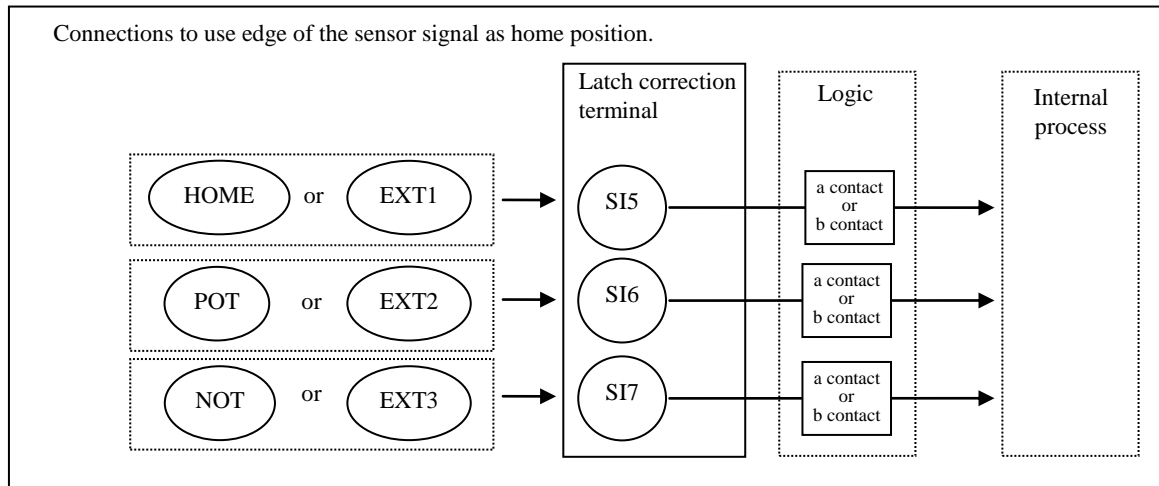

If the conditions 1) to 3) are not met, Err. 33.8 “Latch input allocation error protection” will occur.

- 4) If HOME, POT and NOT are not the home reference trigger, they can be allocated to normal terminal (SI1, SI2, SI3, SI4 and SI8).

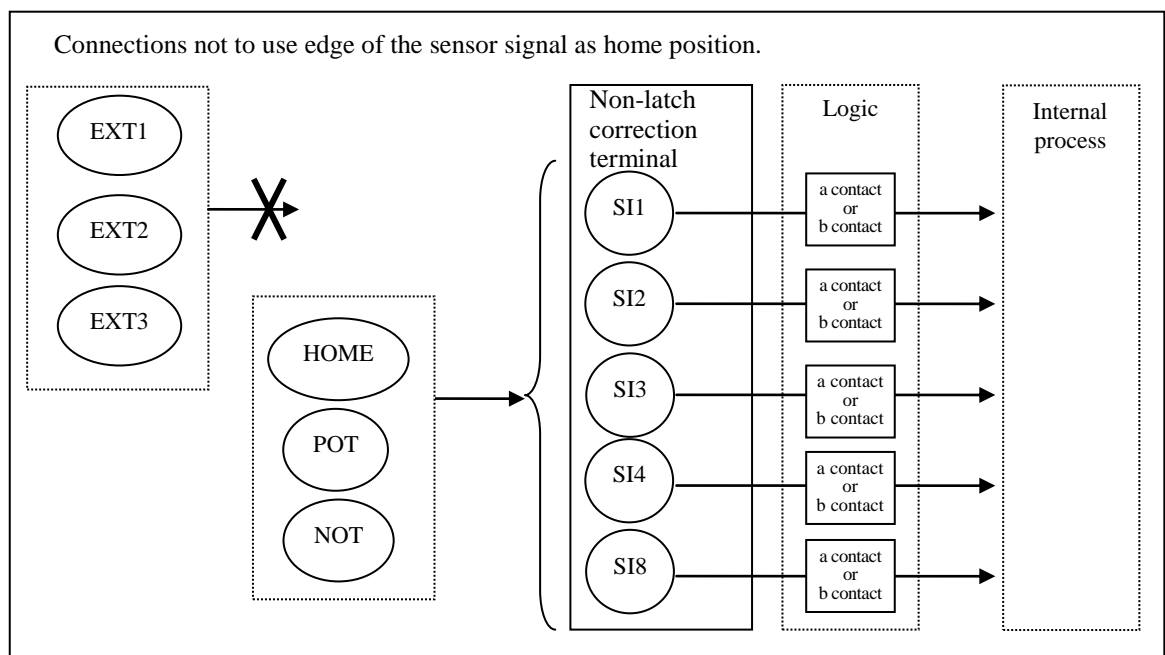

6-5-3 Actual position setup and command position setup

Below shows the internal position information in the servo driver while executing the actual position setup (Type_Code = 021h) and command position setup (Type_Code = 022h).

Type_Code	Designation	Position information after execution
021h	Actual position setup	Actual position = internal command position = setting value (Setting_Data) Position deviation = 0
022h	Command position setup	Internal command position = setting value (Setting_Data) Actual position = internal command position (after setting as described above) – position deviation

Note: For versions corresponding to function extended version 3 or earlier, set up so that the product of setting value (Setting_Data) \times electronic gear ratio is -2^{30} to $2^{30}-1$ [pulse].

<Initialization of position information by actual position setup>

Initialize the motor position (actual position at the time the servo driver received the command) to the setting value to clear the position deviation, and set the internal command position to the motor position (actual position). Subsequently, when the host controller issues a command and motor moves, initialized motor position may deviate from the target position. If this positional deviation may cause problem, use the command position set.

■ Expected application: Homing using stopper See 7-2-3-4.

(If high accuracy is not required: current motor position is initialized to the setting value.)

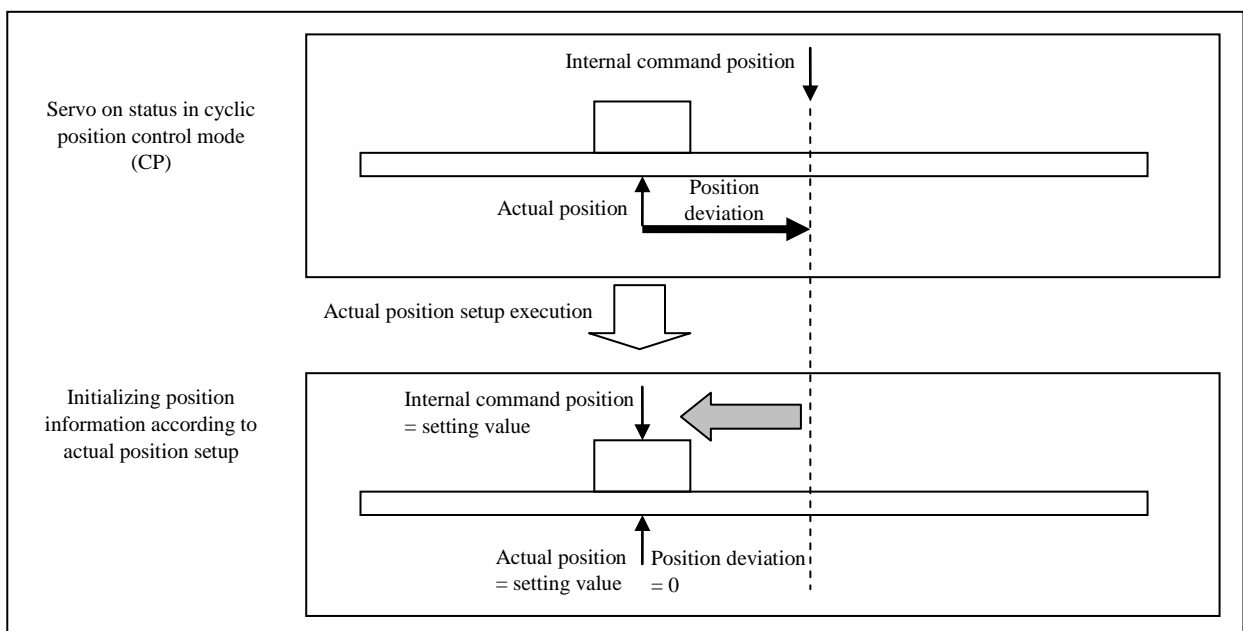

<Initialization of position information according to command position setup>

Upon receiving a command from the host controller, servo driver initializes the internal command position to the setting value while maintaining the current position deviation, and then determines the motor actual position by subtracting position deviation from the setting value. As a result, the motor position is initialized to the presumed position even if the motor moves after the host controller has issued a command provided that the internal command position (after filter) is stopped.

■ Expected application: Homing with respect to latched position

(High accuracy required: internal command position is initialized to the setting value after positioning to the latched position)

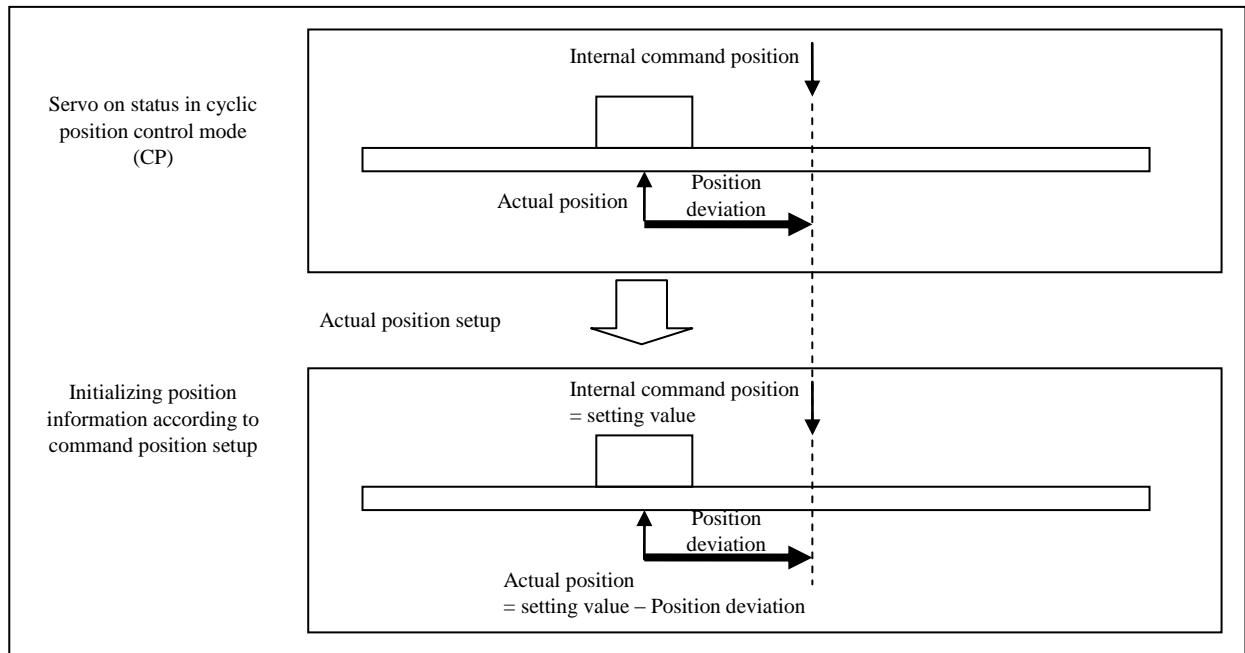

6-5-4 Latch mode

In the latch mode (Type_Code = 5□h), the motor actual position can be latched and read at the input timing of trigger signal without initializing position information.

While in the latch mode, Busy as latch process remains 0. This means that any other command e.g. parameter command can be executed while in the latch mode. However, commands that initialize position information, such as reset command and homing command (except for latch mode) forcibly cancel the established latch mode.

Note: In Latch trigger signal, Latch detection time has a difference with Logical rising edge and Logical falling edge. This servo driver is recommended for Logical rising edge which set a-contact.

6-5-4-1 Starting/canceling latch mode

To start/cancel the latch mode, use Type_Code.
2CHs can be put in the latch mode at the same time.

Byte	Command								Byte	Response							
	bit7	6	5	4	3	2	1	0		bit7	6	5	4	3	2	1	0
8	5				Latch_ Dis2	Latch_ Dis1	Latch_ Ena2	Latch_ Ena1	8	5				Latch_ Dis2_ Echo	Latch_ Dis1_ Echo	Latch_ Ena2_ Echo	Latch_ Ena1_ Echo

	Type_Code				Description
	Latch_ Dis2	Latch_ Dis1	Latch_ Ena2	Latch_ Ena1	
50h	0	0	0	0	Position latch status monitor ▪ Use this to monitor the status without additional starting or canceling.
51h	0	0	0	1	Start position latch 1 (CH1).
52h	0	0	1	0	Start position latch 2 (CH2).
53h	0	0	1	1	Start position latch 1 (CH1) and 2 (CH2).
54h	0	1	0	0	Cancel position latch 1 (CH1).
58h	1	0	0	0	Cancel position latch 2 (CH2).
5Ch	1	1	0	0	Cancel position latch 1 (CH1) and 2 (CH2).

In the table above, "0" means to maintain the current latch start/cancel command without additional latch request/cancel.

6-5-4-2 Selecting latch trigger signal

To select the latch trigger signal, use Latch_Sel1 and Latch_Sel2.

Byte	Command								Byte	Response							
	bit7	6	5	4	3	2	1	0		bit7	6	5	4	3	2	1	0
10	Latch_Sel2				Latch_Sel1				10	Latch_Sel2_Echo				Latch_Sel1_Echo			

	Setting value	Latch trigger signal
Latch_Sel1, Latch_Sel2	0	Z phase *Z-phase of external scale under full-closed * If you use an absolute external scale of the serial communication type in full-close control, a command error (005Ah) is returned.
	1	Logical rising edge of EXT1
	2	Logical rising edge of EXT2
	3	Logical rising edge of EXT3
	4-8	Do not use. If it chooses, a command error (0032h) will be returned.
	9	Logical falling edge of EXT1
	10	Logical falling edge of EXT2
	11	Logical falling edge of EXT3
	12-15	Do not use. If it chooses, a command error (0032h) will be returned.

* Do not set up the same latch trigger signal when starting up Latch_Sel1 and Latch_Sel2 together.

6-5-4-3 Checking latch mode complete status and latch position data

To check the end status of the latch mode, monitor Latch_Comp1 and Latch_Comp2.

To monitor the latch complete status (Latch_Comp1 and Latch_Comp2) again after executing another command, use Type_Code = 50h.

Latch position 1/2 can also be checked by using monitor command.

Command									Response								
Byte	bit7	6	5	4	3	2	1	0	Byte	bit7	6	5	4	3	2	1	0
9	0								9	ERR	WNG	0	Busy	0	0	Latch_Comp2	Latch_Comp1

	Description
Latch_Comp1	0: Latch not completed at latch position 1 (CH1) 1: Latch completed at latch position 1 (CH1)
Latch_Comp2	0: Latch not completed at latch position 2 (CH2) 1: Latch completed at latch position 2 (CH2)

Received latch position 1/2 data can be monitored by using Monitor_Data.

Using Monitor_Sel, select the data to be read out by Monitor_Data.

Use monitor command Type_Code (8-bit) for A6N to set Monitor_Sel.

Command									Response								
Byte	bit7	6	5	4	3	2	1	0	Byte	bit7	6	5	4	3	2	1	0
11	Monitor_Sel								11	Monitor_Sel_Echo							
12									L								
13									ML								
14	Command_Data3								MH								
15									H								

Monitor_Sel	Monitor_Data		Description
	Title	Symbol	
09h	Latch position 1	LPOS1	Actual motor position latched with CH1
0Ah	Latch position 2	LPOS2	Actual motor position latched with CH2

- Note:
- Value of latch position 1/2 is undefined until latch is completed. Make sure that Latch_Comp1 and Latch_Comp2 are at “1”.
 - The values of Latch_Comp1 and Latch_Comp2 are cleared at position latch start (Type_Code: 51h, 52h, 53h). Please note that they are not cleared at position latch cancel (Type_Code: 54h, 58h, 5Ch). Shown below is the timing chart of the latch mode completion state with an example of Latch_Comp1.

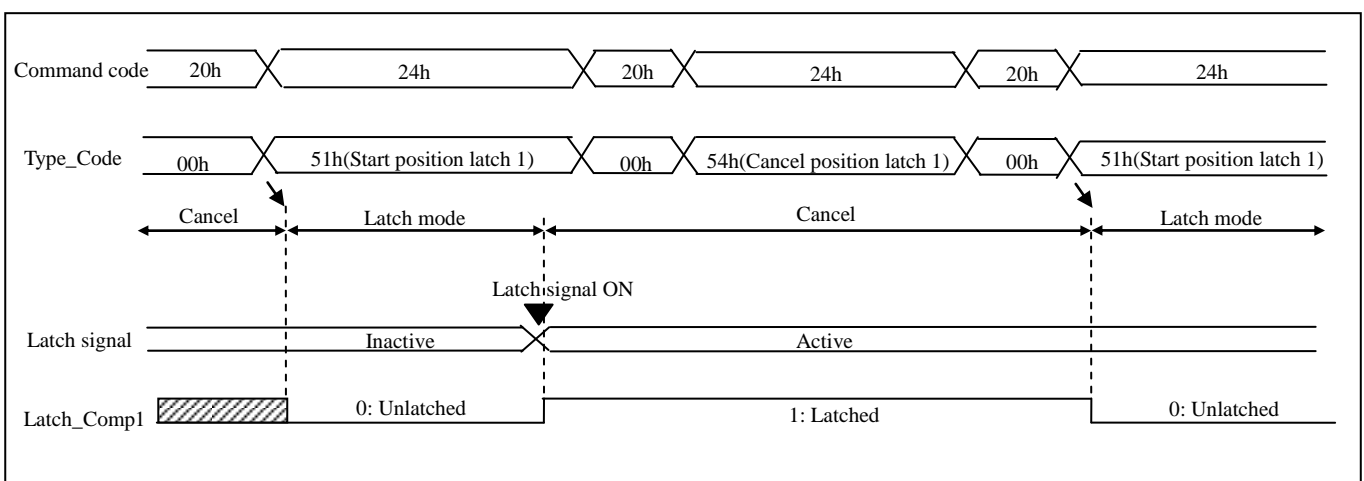

6-5-4-4 Correction function for detection delay of latch position

Correction time for the delay of the latch trigger signal detection can be set by the following parameter.

Class	No.	Attribute	Title	Range	Unit	Function
7	9	B	Correction time of latch delay1	-2000–2000	25ns	Set the correction time for delay of the latch trigger signal detection. This parameter can be switched by Pr7.24 bit5. bit5 is 0: The correction time is reflected in both the latch signal rising edge detection and the latch signal falling edge detection. bit5 is 1: The correction time is reflected in the latch signal rising edge detection. *Signal state of edge detection means the following The rising edge detection means the photocoupler is turned ON. The falling edge detection means the photocoupler is turned OFF.
7	92	B	Correction time of latch delay2	-2000–2000	25ns	Set the correction time for delay of the latch trigger signal detection. This parameter can be switched by Pr7.24 bit5. bit5 is 0: This parameter is disable. bit5 is 1: The correction time is reflected in the latch signal falling edge detection. *Signal state of edge detection means the following The rising edge detection means the photocoupler is turned ON. The falling edge detection means the photocoupler is turned OFF.
7	24	C	RTEX function extended setup 3	-32768–32767	-	bit5 The correction function for detection delay of latch position. 0:The correction time of both the latch signal rising edge detection and the latch signal falling edge detection is set by Pr7.09 1:The correction time of the latch signal rising edge detection is set by Pr7.09, the correction time of the latch signal falling edge detection is set by Pr7.92.

(Note) Delay time of the latch trigger signal detection is different by the operating environment and aging.
In the case of requesting accuracy, please set the correction time of latch delay as necessary.

6-5-5 Latch mode with stop function

This is the function to stop at the latched position with the input/output timing of latch trigger signal with stop function (hereafter referred to as the trigger signal), without initialization of position information.

This function can set up an external input signal (EXT1, EXT2 or EXT3) as the trigger signal. It is also possible to set the amplifier output signal in function extended version 5 and later versions.

When this function is started up using an external input signal (EXT1, EXT2 or EXT3) as the trigger signal, the motor is controlled according to the position commanded by the host device until the trigger signal is input, and it stops at the latched position regardless of the position commanded by the host device once the trigger signal is input. When this function is started using the amplifier output signal as the trigger signal, it will stop at the latched position while neglecting the position commanded by the host device once the amplifier detects the condition for output signal.

In this function, position command filter is disabled during the period from trigger signal detection until it stops at trigger signal detection position so that the command output period until the stop position is reduced.

Selection of trigger signal (external input signal or amplifier output signal) is specified by RTEX communication command.(Refer to Section 6-5-5-2.)

Other commands such as parameter commands cannot be executed after the startup of latch mode with stop function, since Busy is set to 1. Busy is set to 0 and latch mode startup state is also canceled when operation of latch mode with stop function is completed or the operation is canceled.

For the operation sequence of this function, refer to Section 7-2-5.

(1) Applicable range

- This function cannot be applied unless the following conditions are satisfied.

Operating conditions for Latch mode with stop function	
Control mode	• CP control (semi-closed control、 full-closed control)
Other	<ul style="list-style-type: none"> • The software version shall be function extended version 4 or later. • Should be in servo-on condition • Parameters except for controls are correctly set, assuring that the motor can run smoothly. • The communication cycle shall be set to 0.5 ms and command update cycle to 1.0 ms. * The following condition is also necessary for function extended version 4. • The electronic gear ratio shall be set to 1 or larger.

(2) Relevant parameters

Class	No.	Attri-Bute	Title	Range	Unit	Function
7	78	C	Signal reading setting for latch trigger with stop function	0-3	-	The number of readings from external input latch trigger signal input until internal logic confirmation by amplifier with Latch mode with stop function is selected. 0:0.1875ms (3 readings) 1:0.0625ms (1 reading) 2:0.125ms (2 readings) 3:0.1875ms (3 readings)
7	111	C	Trigger signal allocation setting of latch mode with stop function	0-64	-	Select the output signal to be used as the trigger signal in latch mode with stop function. 0:Ineffective 1-5:Used by the manufacturer. 6:Output during torque limitation (TLC) 7-64:Used by the manufacturer.

(3) Caution

- Latch mode with stop function does not start up with the following settings, but returns command error(005Fh).
 - With settings other than cyclic position control (CP),
 - With settings other than command update cycle 1.0 ms and communication cycle 0.5 ms, and
 - With electronic gear ratio setting smaller than 1.

- To start up latch mode with stop function while specifying an external input signal as the trigger signal, assign the trigger signal to one of SI5 to SI7 which is available as an external latch input.
Command error (0058h) is returned if it is started without assignment of the trigger signal.

- To start up latch mode with stop function while specifying the amplifier output signal as the trigger signal, set “6 (output during torque limitation (TLC))” in Pr7.111.
A command error (0058h) will be returned when “0 (invalid)” is set in Pr7.111.

- To use this function on an axis for which the commanded position in command unit wraps around, including an axis turning infinitely in one direction, set the electronic gear ratio to an integral multiple.*1)
(Refer to Section 7-1-4-2 of RTEX communication specification edition of the Technical Reference for wrap around.)

- Err91.3 “RTEX command error protection 2” is generated if cancellation of latch mode with stop function is executed between input/output of the trigger signal and completion of operation.
If this may be a problem, cancel without detection of the trigger signal, such as stopping the motor.

- If the trigger signal is an external input signal, the amount of delay for trigger signal detection will vary depending on the operating environment or aging degradation.
Set up the correction period for amount of delay as necessary if latch precision is required.
For details, refer to Section 6-5-4-4 of technical document RTEX Communication Specification.
There will be no effect of amount of delay correction period if the trigger signal is the amplifier output signal.

*1) This is a restriction only for function extended version 4.

6-5-5-1 Starting up, cancellation and termination of latch mode with stop function

■ Starting up latch mode with stop function

latch mode with stop function starts up by specifying the Type_Code described in the table below.

Byte	Command								Byte	Response							
	bit7	6	5	4	3	2	1	0		bit7	6	5	4	3	2	1	0
8	Fh				Latch_Dis2	Latch_Dis1	Latch_Ena2	Latch_Ena1	8	Fh				Latch_Dis2_Echo	Latch_Dis1_Echo	Latch_Ena2_Echo	Latch_Ena1_Echo

Type_Code					Description
Latch_Dis2	Latch_Dis1	Latch_Ena2	Latch_Ena1		
F1h	0	0	0	1	Start position latch 1 (CH1) with stop function.

< Caution >

- Unlike normal latch mode, latch mode with stop function is supported with only CH1 and CH2 cannot be used. Do not use anything other than the Type_Code described in the table above for startup. Command error (0031h) is returned when a Type_Code other than F1h, such as F2h is transmitted.

■ Cancellation and termination of latch mode with stop function

Latch mode with stop function is canceled under the following conditions.

< Cancellation conditions for latch mode with stop function >

- Homing command (□4h) is changed to a normal command (□0h) after the startup of latch mode with stop function before detection of the trigger signal.
- Servo off state or alarm state is generated after the startup of latch mode with stop function before detection of the trigger signal.

To cancel from the host device, follow the procedure below to control.

< Cancellation procedure for latch mode with stop function >

- When canceling before input/output of the trigger signal, change the homing command (□4h) to a normal command (□0h) after stopping the motor once.

To terminate after completion of the operation of latch mode with stop function, control according to the procedure below.

- Check that the response Byte9 bit0 (Latch_Comp1) is set to “1” for the host device and that the motor is stopped after input/output of the trigger signal, then set up the latch position returned in response Byte12 to 15 (Monitor_Data) as the command position to change the homing command (□4h) to a normal command (□0h).

< Caution >

- Err91.3 “RTEX command error protection 2” is generated if the homing command (□4h) is changed to a normal command (□0h) after input/output of the trigger signal and before response Byte9 bit0 (Latch_Comp1) is returned as “1.”

6-5-5-2 Selection of latch trigger signal with stop function

latch trigger signal with stop function (hereafter referred to as the trigger signal) is selected using command Byte10 bit0 to 3 (Latch_Sel1).

External input signals and amplifier output signal can be set up as the trigger signal.

A common external input signal (EXT1、EXT2、EXT3) with the latch mode is used.

The reading conditions for external input signal is set up with Pr7.78 “Signal reading setting for latch trigger with stop function”.

Byte	Command								Byte	Response							
	bit7	6	5	4	3	2	1	0		bit7	6	5	4	3	2	1	0
10	Latch_Sel2				Latch_Sel1				10	Latch_Sel2_Echo				Latch_Sel1_Echo			

	Setting value	Latch trigger signal
Latch_Sel1	0	Do not use. * If it chooses, a command error (0032h) will be returned.
	1	Logical rising edge of EXT1 *1 *2 *3
	2	Logical rising edge of EXT2 *1 *2 *3
	3	Logical rising edge of EXT3 *1 *2 *3
	4-6	Do not use. * If it chooses, a command error (0032h) will be returned.
	7	Rising edge of the selected output signal *4
	8	Do not use. * If it chooses, a command error (0032h) will be returned.
	9	Logical falling edge of EXT1 *1 *2 *3
	10	Logical falling edge of EXT2 *1 *2 *3
	11	Logical falling edge of EXT3 *1 *2 *3
	12-14	Do not use. * If it chooses, a command error (0032h) will be returned.
	15	Falling edge of the selected output signal *4
	Latch_Sel2	Set it as 0.

For response Byte10 bit0 to 3 (Latch_Sel1_Echo), the value for Latch_Sel1 will be returned.

For response Byte10 bit4 to 7 (Latch_Sel2_Echo), the value for Latch_Sel2 will be returned.

- *1) Assign the trigger signal as an external latch input to one of SI5 to SI7 available.
- *2) Logic for the trigger signal (a-contact/b-contact) depends on the amplifier parameter setting.
Please use by setting up the parameters corresponding to the external latch input signal to be used (Pr4.04 to Pr4.06) properly.
- *3) Since the photocoupler used in signal detection is an open collector type, set up with the rising logic edge of “a-contact” for applications which require responsiveness.
- *4) It is not supported by function extended version 4 and earlier versions.
Set up the output signal to be used as the trigger signal in parameter Pr7.111
“Trigger signal assignment setup for latch mode with stop function.”

6-5-5-3 State of latch mode with stop function and check on latch position data

■ State of latch mode with stop function

For the state of latch mode with stop function, monitor response Byte9.

Byte	Command								Byte	Response							
	bit7	6	5	4	3	2	1	0		bit7	6	5	4	3	2	1	0
9	0								9	ERR	WNG	0	Busy	0	0	Latch_Comp2	Latch_Comp1

bit	Title	Description
0	Latch_Comp1	Indicates the state of completion of operation by latch mode with stop function. (0: Not complete, 1: Complete)
1	Latch_Comp2	0 is always returned for latch mode with stop function.
6	WNG	0 is always returned for latch mode with stop function.

Refer to Section 3-3-2 for the behavior of bits other than the above.

The behavior of each bit in response Byte9 for latch mode with stop function is shown in the timing chart below.

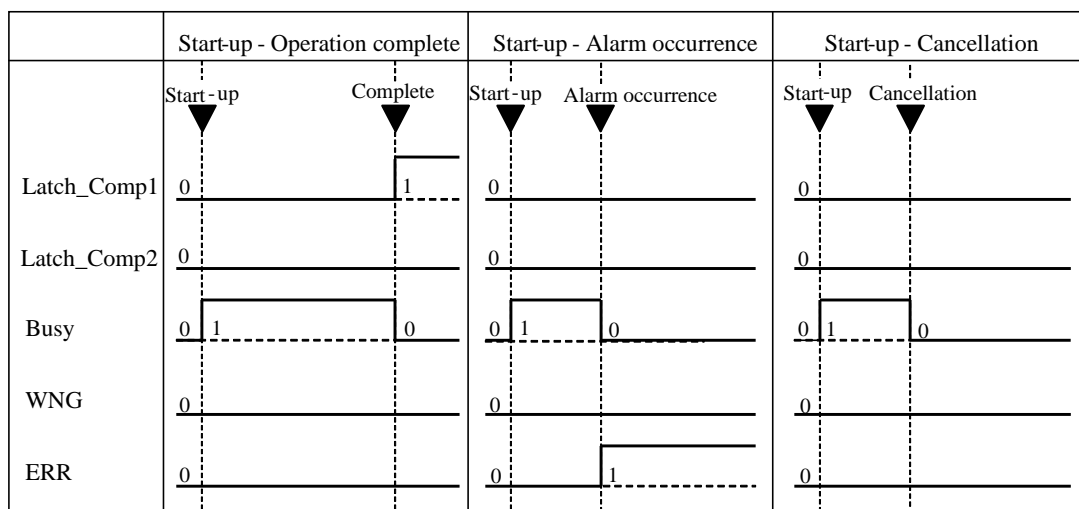

■ Check on latch position data for latch mode with stop function

The latch position data for latch mode with stop function can be checked using response Byte12 to 15 (Monitor_Data) only when command Byte11 (Monitor_Sel) is set to 09h (LPOS1).

“0” is returned as Monitor_Data if a value other than 09h is set up in Monitor_Sel.

Byte	Command								Byte	Response									
	bit7	6	5	4	3	2	1	0		bit7	6	5	4	3	2	1	0		
11	Monitor_Sel								11	Monitor_Sel_Echo									
12	Command_Data3								L	12	Monitor_Data								L
13									M	13									M
14									L	14									L
15									M	15									M
									H										H

Monitor_Sel	Monitor_Data		Description
	Title	Symbol	
09h	Latch position 1	LPOS1	Actual position of motor latched by latch mode with stop function[Command unit]

< Caution >

- The value for latch position 1 with the state of latch mode with stop function being incomplete (Latch_Comp1=0) will be undefined.
Be sure to also check that the completion state for latch mode with stop function is “1.”
- The value for Latch_Comp1 is cleared to “0” at the startup of latch mode with stop function(Type_Code:F1h).

6-6 Alarm command (Command code: □5h)

Use this to read out alarm code or clear the present alarm.

Compatible control mode				
NOP	PP	CP	CV	CT
-	○	○	○	○

■ Main command: Common to 16 byte and 32 byte mode

Byte	Command								Byte	Response								
	bit7	6	5	4	3	2	1	0		bit7	6	5	4	3	2	1	0	
0	C (0)	Update_Counter		MAC-ID					0	R (1)	Update_Counter_Echo		Actual_MAC-ID					
1	TMG_ CNT	□5h							1	CMD_ Error	□5h							
2	Control_Bits								2	Status_Flags								
3									3									
4									L	4								
5	Command_Data1								ML	5	Response_Data1							
6									MH	6								
7									H	7								
8	Type_Code								L	8	Type_Code_Echo							
9	0								H	9	ERR	WNG	0	Busy				
10									L	10								
11	Index								H	11	Index_Echo							
12									L	12	Alarm_Code							
13	Command_Data3								ML	13	Main							
14									MH	14	Sub							
15									H	15	Warning_Code							

■ Sub-command: Only for 32 byte mode

Alarm command does not support the sub-command.

Title	Command	Response		
Type_Code /Type_Code_Echo	Type of execution, e.g. alarm readout and clear ▪ For details, refer to Section 6-6-1.	Echo back value of Type_Code		
Index /Index_Echo	Set up history number etc. ▪ For details, refer to Section 6-6-1.	<Except for alarm attribute readout> Echo back value of Index		
		<To read out alarm attribute>		
		<table border="1"> <tr> <td>Index: 0</td> <td>Alarm code being issued</td> </tr> <tr> <td>Index: not 0</td> <td>Echo back value of Index</td> </tr> </table>	Index: 0	Alarm code being issued
Index: 0	Alarm code being issued			
Index: not 0	Echo back value of Index			
Command_Data3	Data specified by Pr.7.35 "RTEX command setting 1" ▪ For details, refer to Sections 7-7-1.	—		
Alarm_Code	—	< In the case of other than alarm attribute read out, multiple alarms/warnings read out, alarm accessory information read out > Alarm code ▪ For details, see 6-6-1 and 6-6-2.		
		<To read out alarm attribute> Alarm attribute ▪ For details, see 6-6-3.		
		< In the case of multiple alarms/warnings read out > Alarm and warning information (Lower 16 bits) ▪ For details, see 6-6-4.		
		< In the case of alarm accessory information read out > Alarm accessory information (Lower 16 bits) ▪ For details, see 6-6-5.		
Warning_Code	—	< In the case of other than alarm attribute read out, multiple alarms/warnings read out, alarm accessory information read out > Warning code ▪ For details, see 6-6-1.		
		<To read out alarm attribute> Alarm attribute ▪ For details, see 6-6-3.		
		< In the case of multiple alarms/warnings read out > Alarm and warning information (Higher 16 bits) ▪ For details, see 6-6-4.		
		< In the case of alarm accessory information read out > Alarm accessory information (Higher 16 bits) ▪ For details, see 6-6-5.		

6-6-1 Alarm command Type_Code list

Type_Code *1)	Title	Description																		
000h	Read out present alarm or alarm history	<ul style="list-style-type: none"> When Index is 0, present alarm code (Alarm_Code) and warning code (Warning_Code) will be read out. When Index is 1 to 14, past alarm code (alarm history) will be read out. Larger Index value represents older alarm history. Because the warning code (Warning_Code) is not recorded, Index code is always 0. When alarm does not have occurred, 0 will be read at alarm code. <table border="1"> <thead> <tr> <th>Index</th> <th>Alarm_Code</th> <th>Warning_Code</th> </tr> </thead> <tbody> <tr> <td>0</td> <td>The code representing the current alarm</td> <td>The code representing the current warning</td> </tr> <tr> <td>1</td> <td>The code for the last alarm</td> <td>0</td> </tr> <tr> <td>2</td> <td>The code for the second last alarm</td> <td>0</td> </tr> <tr> <td>:</td> <td>:</td> <td>:</td> </tr> <tr> <td>14</td> <td>The code for the fourteenth last alarm</td> <td>0</td> </tr> </tbody> </table> <ul style="list-style-type: none"> When an alarm is generated, even if a new alarm is generated, it will not be updated to the latest condition. The warning code will be updated according to the following order of priority. Warning code: (Highest priority) C0>C1>C2>A1-A9>AC>C3>D2 When Index is not 0–14, Command error (0032h) will be returned. Set Data specified by Pr.7.35 “RTEX command setting 1” as Command_Data3. When Pr.7.35 “RTEX command setting 1” is 0, and Command_Data3 is not 0, Command error (0032h) will be returned. Some alarms are not recorded. When the value read out with Index = 0 is 0, it means that no alarm or warning has occurred. If an alarm occurs while the previously occurred alarm is recorded in the history, the value of the alarm code (Index = 0) for the new alarm is the same as the value of the alarm code (Index = 1) for the preceding alarm. 	Index	Alarm_Code	Warning_Code	0	The code representing the current alarm	The code representing the current warning	1	The code for the last alarm	0	2	The code for the second last alarm	0	:	:	:	14	The code for the fourteenth last alarm	0
Index	Alarm_Code	Warning_Code																		
0	The code representing the current alarm	The code representing the current warning																		
1	The code for the last alarm	0																		
2	The code for the second last alarm	0																		
:	:	:																		
14	The code for the fourteenth last alarm	0																		

Type_Code *1)	Title	Description											
001h	Clear alarm	<ul style="list-style-type: none"> When Index is 0, present alarm and warning will be cleared. And present alarm code (Alarm_Code) and warning code (Warning_Code) will be returned. After alarm clear is performed, the alarm code will be updated to the latest condition. The warning code will be updated according to the following order of priority. Warning code: (Highest priority) C0>C1>C2>A1-A9>AC>C3>D2 When Index is not 0, Command error (0032h) will be returned. Set Data specified by Pr.7.35 "RTEX command setting 1" as Command_Data3. When Pr.7.35 "RTEX command setting 1" is 0, and Command_Data3 is not 0, Command error (0032h) will be returned. When you try to execute this command to clear the alarm which is inhibited to clear, or when you try to do so when no warning occurs, command error (0042h) will be returned.(When the alarm which is inhibited to clear and warning occurred on same time, since clearing process of warning is performed, Command error (0042h) is not returned.) Clear the warning by executing this command when "battery warning" of the absolute encoder has occurred. And when the alarm which is inhibited to clear has also occurred, this warning will be cleared. Clearing process may require approx. 10 s for completion. As clearing process starts, warning will be put in "cleared" state for approx. 1 second, even if the cause of warning has not been removed. Note that the 1-second clearing process is not interlocked with Busy. 											
002h	Read out alarm attribute	<ul style="list-style-type: none"> Using Index, specify the number of alarm for reading the alarm attribute. <table border="1" data-bbox="651 1451 1449 1585"> <thead> <tr> <th>Byte</th> <th colspan="2">Title</th> <th>Specified alarm code</th> </tr> </thead> <tbody> <tr> <td>10</td> <td rowspan="2">Index</td> <td>L</td> <td>Alarm code main number</td> </tr> <tr> <td>11</td> <td>H</td> <td>Alarm code sub number</td> </tr> </tbody> </table> When Index is 0 (L and H are 0), attribute of the current alarm is read, with the alarm code of the current alarm is returned in Index_Echo. If no alarm, Index_Echo and alarm attribute are returned with 0. If undefined alarm code is specified, command error 0032h will be returned. Set Data specified by Pr.7.35 "RTEX command setting 1" as Command_Data3. When Pr.7.35 "RTEX command setting 1" is 0, and Command_Data3 is not 0, Command error (0032h) will be returned. Alarm attribute is returned in Bytes 12–15 of response. 	Byte	Title		Specified alarm code	10	Index	L	Alarm code main number	11	H	Alarm code sub number
Byte	Title		Specified alarm code										
10	Index	L	Alarm code main number										
11		H	Alarm code sub number										

*1) Command error (0031h) will be returned at setting up the wrong type code.

Type_Code *1)	Title	Description			
004h	Read out multiple alarm/warning information	• Set the alarm/warning information to read out by Index.			
		Byte	name	Setting value	Information to be read
		10	Index-L	00h	Invalid
				01h	Alarm information of alarm main numbers 0 to 31
				02h	Alarm information of alarm main numbers 32 to 63
				03h	Alarm information of alarm main numbers 64 to 95
				04h	Alarm information of alarm main numbers 96 to 127
				11h	Warning information of warning codes A0h to BFh
				12h	Warning information of warning codes C0h to DFh
		Other than the above	Do not use.		
11	Index-H	00h	Invalid		
		Alarm main number	Alarm information of the sub number of the set alarm main number		
<ul style="list-style-type: none"> • Alarm information and warning information are converted to bits, and when alarm/warning occurs, 1 is returned to an applicable bit and when alarm/warning does not occur, 0 is returned. Example: Read-out information at the occurrence of Err27.4 When Index-L=1 (01h), in order to return the main number of alarm that occurred at alarm main numbers 0 to 31, 1 is returned to bit 27 (Byte 15, bit 3) that indicates Err27 at the occurrence of Err27.4. When Index-H=27 (1Bh), in order to return the sub number of alarm that occurred at alarm main number 27, 1 is returned to bit 4 (Byte 12, bit 4) that indicates Err27.4 at the occurrence of Err27.4. • Index-L and Index-H cannot be used at the same time. Be sure to set either Index-L or Index-H to 00h (invalid). If they are used at the same time, command error (0032h) will be returned. • If other than 00h to 04h. 11h and 12h is set to Index-L, command error (0032h) will be returned. • If an alarm number that does not exist is set to Index-H, 0 will be returned. • Set Data specified by Pr.7.35 “RTEX command setting 1” as Command_Data3. • When Pr.7.35 “RTEX command setting 1” is 0, and Command_Data3 is not 0, Command error (0032h) will be returned. 					

Type_Code *1)	Title	Description
011h	Clear alarm history	<ul style="list-style-type: none"> When Index is 0, all alarm history will be cleared. And present alarm code (Alarm_Code) and warning code (Warning_Code) will be returned. When an alarm is generated, even if a new alarm is generated, it will be updated to the latest condition. The warning code will be updated according to the following order of priority. Warning code: (Highest priority) C0>C1>C2>A1-A9>AC>C3>D2 When Index is not 0, Command error (0032h) will be returned. Set Data specified by Pr.7.35 "RTEX command setting 1" as Command_Data3. When Pr.7.35 "RTEX command setting 1" is 0, and Command_Data3 is not 0, Command error (0032h) will be returned. Alarm history is stored to EEPROM. When Err. 11.0 Control power supply under-voltage protection occurs, command error (0061h) will be returned because of EEPROM accessing failure.
021h	External scale error clear	<ul style="list-style-type: none"> When Index = 0, under full closed control mode or semi-closed control mode (when external scale position information monitor function is not effective in semi-closed control), clears the error latched by serial communications type external scale. (It is not the clearing of alarm condition inside the servo amplifier.) And present alarm code (Alarm_Code) and warning code (Warning_Code) will be returned. When an alarm is generated, even if a new alarm is generated, it will not be updated to the latest condition. The warning code will be updated according to the following order of priority. Warning code: (Highest priority) C0>C1>C2>A1-A9>AC>C3>D2 It will return command error (0032h) when Index is other than 0. Set Data specified by Pr.7.35 "RTEX command setting 1" as Command_Data3. When Pr.7.35 "RTEX command setting 1" is 0, and Command_Data3 is not 0, Command error (0032h) will be returned. In full-closed control mode, at the time of ABZ external scale, in semi-closed control (when external scale position information monitor function is not effective in semi-closed control) or when external scale error does not occur, command error (0043h) will be returned. Please shut down the control power and reset, after executing error clear of external scale. Time required for clearing may vary with the specifications of the external scale. Please check the external scale specifications and secure ample allowance for the time required for the clearing process.

*1) Command error (0031h) will be returned at setting up the wrong type code.

Type_Code *1)	Title	Description
0A0h	Read out present alarm accessory information	<ul style="list-style-type: none"> • Acquire the accessory information of present alarm (driver information when the alarm occurs). • Since there are multiple pieces of alarm accessory information, specify Index to acquire. Refer to Section 6-6-5 for details. • If alarm occurs while alarm accessory information is being acquired, alarm accessory information is latched in order to prevent the alarm accessory information from being inconsistent, and the alarm accessory information being acquired will be returned. A latch start condition and latch clear conditions are as follows: <ul style="list-style-type: none"> [Latch start condition] <ul style="list-style-type: none"> • Receives “read out alarm accessory information” command. [Latch clear condition] <ul style="list-style-type: none"> • Receives “Clear alarm history” command (RTEX command, USB command) • Receives alarm command or a command other than regular command. • RTEX communication is cut off. • When Index is other than 00h to 23h, command error (0032h) is returned. • When Pr.7.35 “RTEX command setting 1” is 0, and Command_Data3 is not 0, Command error (0032h) will be returned. • If there is no alarm accessory information, 0 is returned.
0A1h	Read out alarm accessory information of the latest alarm	<ul style="list-style-type: none"> • Acquire the accessory information of the first alarm (driver information when the alarm occurs). • Since there are multiple pieces of alarm accessory information, specify Index to acquire. Refer to Section 6-6-5 for details. • If alarm occurs while alarm accessory information is being acquired, alarm accessory information is latched in order to prevent the alarm accessory information from being inconsistent, and the alarm accessory information being acquired will be returned. A latch start condition and latch clear conditions are as follows: <ul style="list-style-type: none"> [Latch start condition] <ul style="list-style-type: none"> • Receives “read out alarm accessory information” command. [Latch clear condition] <ul style="list-style-type: none"> • Receives “Clear alarm history” command (RTEX command, USB command) • Receives alarm command or a command other than regular command. • RTEX communication is cut off. • When Index is other than 00h to 23h, command error (0032h) is returned. • When Pr.7.35 “RTEX command setting 1” is 0, and Command_Data3 is not 0, Command error (0032h) will be returned. • If there is no alarm accessory information, 0 is returned. • If a new alarm occurs while retrieving alarm accessory information, retrieve it again.

Type_Code *1)	Title	Description
0A2h	Read out accessory information of alarm that occurred 2 times before	<ul style="list-style-type: none"> • Acquire the accessory information of the second alarm (driver information when the alarm occurs). • Since there are multiple pieces of alarm accessory information, specify Index to acquire. Refer to Section 6-6-5 for details. • If alarm occurs while alarm accessory information is being acquired, alarm accessory information is latched in order to prevent the alarm accessory information from being inconsistent, and the alarm accessory information being acquired will be returned. A latch start condition and latch clear conditions are as follows: [Latch start condition] <ul style="list-style-type: none"> • Receives “read out alarm accessory information” command. [Latch clear condition] <ul style="list-style-type: none"> • Receives “Clear alarm history” command (RTEX command, USB command) • Receives alarm command or a command other than regular command. • RTEX communication is cut off. • When Index is other than 00h to 23h, command error (0032h) is returned. • When Pr.7.35 “RTEX command setting 1” is 0, and Command_Data3 is not 0, Command error (0032h) will be returned. • If there is no alarm accessory information, 0 is returned. • If a new alarm occurs while retrieving alarm accessory information, retrieve it again.
0A3h	Read out accessory information of alarm that occurred 3 times before	<ul style="list-style-type: none"> • Acquire the accessory information of the third alarm (driver information when the alarm occurs). • Since there are multiple pieces of alarm accessory information, specify Index to acquire. Refer to Section 6-6-5 for details. • If alarm occurs while alarm accessory information is being acquired, alarm accessory information is latched in order to prevent the alarm accessory information from being inconsistent, and the alarm accessory information being acquired will be returned. A latch start condition and latch clear conditions are as follows: [Latch start condition] <ul style="list-style-type: none"> • Receives “read out alarm accessory information” command. [Latch clear condition] <ul style="list-style-type: none"> • Receives “Clear alarm history” command (RTEX command, USB command) • Receives alarm command or a command other than regular command. • RTEX communication is cut off. • When Index is other than 00h to 23h, command error (0032h) is returned. • When Pr.7.35 “RTEX command setting 1” is 0, and Command_Data3 is not 0, Command error (0032h) will be returned. • If there is no alarm accessory information, 0 is returned. • If a new alarm occurs while retrieving alarm accessory information, retrieve it again.

6-6-2 Setting up of alarm code

With MINAS-A6N series, an alarm code (Alarm_Code) is divided into the main and sub numbers. By using bit 1 of Pr.7.23 "RTEX function extended setup 2", however, only the main number can be used as in the case of MINAS-A4N. Note that both the main and sub number should be specified when reading alarm attribute.

Byte	Title		Bit 1 of Pr.7.23	
			0 (A4N compatible)	1
12	Alarm_Code	Main	Main number	Main number
13		Sub	0	Sub number

6-6-3 Alarm attribute

Byte	bit7	6	5	4	3	2	1	0
12	NOT_REC	NOT_ACLR	EMG-STP	-	-	-	-	-
13	-	-	-	-	-	-	-	-
14	-	-	-	-	-	-	-	-
15	-	-	-	-	-	-	-	-

NOT_REC: Do not record in alarm history.

NOT_ACLR: Do not clear.

EMG-STP: Enable emergency stop.

6-6-4 Multiple alarm/warning information

When multiple alarms/warnings occur, 1 is returned to an applicable bit. When it does not occur, 0 is returned.

Index-L	Byte	bit7	6	5	4	3	2	1	0
01h	12	Err7.*	Err6.*	Err5.*	Err4.*	Err3.*	Err2.*	Err1.*	Err0.*
	13	Err15.*	Err14.*	Err13.*	Err12.*	Err11.*	Err10.*	Err9.*	Err8.*
	14	Err23.*	Err22.*	Err21.*	Err20.*	Err19.*	Err18.*	Err17.*	Err16.*
	15	Err31.*	Err30.*	Err29.*	Err28.*	Err27.*	Err26.*	Err25.*	Err24.*
Index-L	Byte	bit7	6	5	4	3	2	1	0
02h	12	Err39.*	Err38.*	Err37.*	Err36.*	Err35.*	Err34.*	Err33.*	Err32.*
	13	Err47.*	Err46.*	Err45.*	Err44.*	Err43.*	Err42.*	Err41.*	Err40.*
	14	Err55.*	Err54.*	Err53.*	Err52.*	Err51.*	Err50.*	Err49.*	Err48.*
	15	Err63.*	Err62.*	Err61.*	Err60.*	Err59.*	Err58.*	Err57.*	Err56.*
Index-L	Byte	bit7	6	5	4	3	2	1	0
03h	12	Err71.*	Err70.*	Err69.*	Err68.*	Err67.*	Err66.*	Err65.*	Err64.*
	13	Err79.*	Err78.*	Err77.*	Err76.*	Err75.*	Err74.*	Err73.*	Err72.*
	14	Err87.*	Err86.*	Err85.*	Err84.*	Err83.*	Err82.*	Err81.*	Err80.*
	15	Err95.*	Err94.*	Err93.*	Err92.*	Err91.*	Err90.*	Err89.*	Err88.*
Index-L	Byte	bit7	6	5	4	3	2	1	0
04h	12	Err103.*	Err102.*	Err101.*	Err100.*	Err99.*	Err98.*	Err97.*	Err96.*
	13	Err111.*	Err110.*	Err109.*	Err108.*	Err107.*	Err106.*	Err105.*	Err104.*
	14	Err119.*	Err118.*	Err117.*	Err116.*	Err115.*	Err114.*	Err113.*	Err112.*
	15	Err127.*	Err126.*	Err125.*	Err124.*	Err123.*	Err122.*	Err121.*	Err120.*
Index-L	Byte	bit7	6	5	4	3	2	1	0
11h	12	WngA7h	WngA6h	WngA5h	WngA4h	WngA3h	WngA2h	WngA1h	WngA0h
	13	WngAFh	WngAEh	WngADh	WngACh	WngABh	WngAAh	WngA9h	WngA8h
	14	WngB7h	WngB6h	WngB5h	WngB4h	WngB3h	WngB2h	WngB1h	WngB0h
	15	WngBFh	WngBEh	WngBDh	WngBCh	WngBBh	WngBAh	WngB9h	WngB8h
Index-L	Byte	bit7	6	5	4	3	2	1	0
12h	12	WngC7h	WngC6h	WngC5h	WngC4h	WngC3h	WngC2h	WngC1h	WngC0h
	13	WngCFh	WngCEh	WngCDh	WngCCh	WngCBh	WngCAh	WngC9h	WngC8h
	14	WngD7h	WngD6h	WngD5h	WngD4h	WngD3h	WngD2h	WngD1h	WngD0h
	15	WngDFh	WngDEh	WngDDh	WngDCCh	WngDBh	WngDAh	WngD9h	WngD8h
Index-H	Byte	bit7	6	5	4	3	2	1	0
*	12	Err*.7	Err*.6	Err*.5	Err*.4	Err*.3	Err*.2	Err*.1	Err*.0
	13	Err*.15	Err*.14	Err*.13	Err*.12	Err*.11	Err*.10	Err*.9	Err*.8
	14	Err*.23	Err*.22	Err*.21	Err*.20	Err*.19	Err*.18	Err*.17	Err*.16
	15	Err*.31	Err*.30	Err*.29	Err*.28	Err*.27	Err*.26	Err*.25	Err*.24

*The table above includes the alarm numbers and warning numbers that do not exist.

Example: Read-out information at the occurrence of Err27.4

When Index-L=1 (01h), in order to return the main number of alarm that occurred at alarm main numbers 0 to 31, 1 is returned to bit 7 (Byte 15, bit 3) that indicates Err27 at the occurrence of Err27.4.

When Index-H=27 (1Bh), in order to return the sub number of alarm that occurred at alarm main number 27, 1 is returned to bit 4 (Byte 12, bit 4) that indicates Err27.4 at the occurrence of Err27.4.

The example of the steps to read out multiple alarm information is indicated below.

Example: When reading out multiple alarm information in the state where Err26.1 and Err38.0 occur at the same time.

- 1) Set Type_Code=004h, Index-L=01h and Index-H=00h, and acquire the alarm information of alarm main numbers 0 to 31. When Err26.1 occurs, 1 is returned to bit 26 (Byte 15, bit 2).
- 2) Set Type_Code=004h, Index-L=02h and Index-H=00h, and acquire the alarm information of alarm main numbers 32 to 63. When Err38.0 occurs, 1 is returned to bit 6 (Byte 12, bit 6).
- 3) Set Type_Code=004h, Index-L=03h and Index-H=00h, and acquire the alarm information of alarm main numbers 64 to 95. Since an applicable alarm did not occur, 0 is returned.
- 4) Set Type_Code=004h, Index-L=04h and Index-H=00h, and acquire the alarm information of alarm main numbers 96 to 127. Since an applicable alarm did not occur, 0 is returned.

Next, acquire an alarm sub number with respect to the alarm main number of the alarm that occurred.

- 5) Set Type_Code=004h, Index-L=00h and Index-H=26 (1Ah), and acquire the alarm sub number of alarm main number 26. When Err26.1 occurs, 1 is returned to bit 1 (Byte 12, bit 1).
- 6) Set Type_Code=004h, Index-L=00h and Index-H=38 (26h), and acquire the alarm sub number of alarm main number 38. When Err38.0 occurs, 1 is returned to bit 0 (Byte 12, bit 0).

Note: Multiple alarm information returns the latest alarm state when receiving a command.

6-6-5 Alarm accessory information

The reference table of Index and read-out data is indicated below.

Index	Read data	unit
01h	Alarm code	-
02h	Control mode	-
03h	Motor speed	r/min
04h	Positional command velocity	r/min
05h	Velocity control command	r/min
06h	Torque command	0.05% *1)
07h	Position command deviation	Command unit
08h	Motor position	Encoder unit
09h	Hybrid deviation	Command unit
0Ah	Input port (logic signal)	-
0Bh	Output port (logic signal)	-
0Ch	Analog input	AD value
0Fh	Overload ratio	0.2% *1)
10h	Regenerative load ratio	%
11h	Voltage across PN	V
12h	Driver temperature	°C
13h	Warning flags *2) *3)	-
14h	Inertia ratio	%
18h	Encoder temperature	°C
1Ch	U-phase current detection value	AD value
1Dh	W-phase current detection value	AD value
20h	Encoder single-turn data	Encoder unit
21h	Number of continuous occurrences of encoder communication errors	No of times
22h	Number of continuous occurrences of external scale communication errors	No of times

*1) Note that it differs from the unit of data acquired by monitor command.

*2) It is not supported in versions corresponding to function extended edition 2 or earlier.

*3) The following bit assignment is used for warning flags in alarm accessory information.
It varies from the bit assignment for warning flags read by monitor command.

	bit 7	bit 6	bit 5	bit 4	bit 3	bit 2	bit 1	bit 0
Byte 12	Overload	Fun lock	Regenerative overload	Encoder communication	Encoder overheating	Lifetime detection	-	Battery
Byte 13	-	Scale communication	Oscillation detection	Main power source off	Update counter	Cumulative communication error	Continuous communication error	Scale error
Byte 14	-	-	-	-	-	-	-	-
Byte 15	-	-	-	-	-	-	-	-

6-7 Parameter Command (Command code: □6h)

Use this to read out, to write the parameter and to write to EEPROM.

Compatible control mode				
NOP	PP	CP	CV	CT
-	○	○	○	○

■ Main command: Common to 16 byte and 32 byte mode

Byte	Command								Byte	Response								
	bit7	6	5	4	3	2	1	0		bit7	6	5	4	3	2	1	0	
0	C (0)	Update_Counter		MAC-ID					0	R (1)	Update_Counter_Echo		Actual_MAC-ID					
1	TMG_CNT	□6h							1	CMD_Error	□6h							
2	Control_Bits								2	Status_Flags								
3									3									
4									L	4								
5	Command_Data1								ML	5	Response_Data1							
6									MH	6								
7									H	7								
8	Type_Code								L	8	Type_Code_Echo							
9	0								H	9	ERR	WNG	0	Busy				
10	Index								L	10	Index_Echo							
11									H	11								
12	Setting_Data								L	12	Monitor_Data							
13	(Command_Data3)								ML	13								
14									MH	14								
15									H	15								

■ Sub-command: Only for 32 byte mode

Parameter command does not support the sub-command.

Title	Command	Response
Type_Code /Type_Code_Echo	Type of execution, e.g. reading and writing of parameter ▪ For details, refer to Section 6-7-1.	Echo back value of Type_Code
Index /Index_Echo	Parameter number (Type, No.) ▪ For details, refer to Section 6-7-1.	Echo back value of Index
Setting_Data (Command_Data3) /Monitor_Data	<Reading parameter> Data specified by Pr.7.35 "RTEX command setting 1" ▪ For details, refer to Sections 7-7-1.	<Reading parameter> Parameter value read out *2) [Size]: Signed 32-bit [Unit]: Dependent on parameter ▪ For details, refer to Section 6-7-1.
	<Writing parameter> Parameter setting value *1) [Size]: Signed 32-bit [Unit]: Dependent on parameter [Setting range]: Dependent on parameter ▪ For details, refer to Section 6-7-1.	<Writing parameter> Parameter value actually written *2) [Size]: Signed 32-bit [Unit]: Dependent on parameter ▪ For details, refer to Section 6-7-1.
	< Parameter initial value read-out > Data specified by Pr.7.35 "RTEX command setting 1" ▪ For details, refer to Sections 7-7-1.	< Parameter initial value read-out > Parameter initial value read out *2) [Size]: Signed 32-bit [Unit]: Dependent on parameter ▪ For details, refer to Section 6-7-1.
	<The number read-out of the parameters in a classification> Data specified by Pr.7.35 "RTEX command setting 1" ▪ For details, refer to Sections 7-7-1.	<The number read-out of the parameters in a classification> The number of parameters in a classification ▪ For details, refer to Sections 6-7-3.
	<Parameter attribute read-out> Data specified by Pr.7.35 "RTEX command setting 1" ▪ For details, refer to Sections 7-7-1.	<Parameter attribute read-out> Parameter attribute ▪ For details, refer to Sections 6-7-4.
	<Writing to EEPROM> Data specified by Pr.7.35 "RTEX command setting 1" ▪ For details, refer to Sections 7-7-1.	<Writing to EEPROM> 0 is returned.

*1) When the parameter value is 16-bit length, convert it to 32-bit.

Example: When -1000, set to FFFF18h

(Byte 15 = FFh, Byte 14 = FFh, Byte 13 = FCh, Byte 12 = 18h)

*2) When the parameter value is 16-bit length, it is converted to 32-bit and then returned.

During process, the value (Busy = 1) is unstable.

6-7-1 Type code list of parameter command

Type_Code *1)		Title	Description									
A4N compatible	standard											
000h	-	Undefined	<ul style="list-style-type: none"> Do not use this Type_Code with MINAS-A6N. Command error (0031h) will be returned 									
001h	-	Undefined	<ul style="list-style-type: none"> Do not use this Type_Code with MINAS-A6N. Command error (0031h) will be returned 									
-	010h	Parameter reading	<ul style="list-style-type: none"> Use this to read out the parameter value from the servo driver. Set the parameter number (class, No.) to Index of command. <table border="1" data-bbox="715 544 1270 665"> <thead> <tr> <th>Byte</th> <th>Title</th> <th>Description</th> </tr> </thead> <tbody> <tr> <td>10</td> <td>Index-L</td> <td>Parameter No.</td> </tr> <tr> <td>11</td> <td>Index-H</td> <td>Parameter class</td> </tr> </tbody> </table> Set the data specified in Pr.7.35 "RTEX command setting 1" to Setting_Data of command. Return the readout value as Monitor_Data in the response. If Index is unsupported parameter number (No. or class is outside of range) , command error 0032h will be returned. When Pr.7.35 "RTEX command setting 1" is 0, and Command_Data3 is not 0, Command error (0032h) will be returned. 	Byte	Title	Description	10	Index-L	Parameter No.	11	Index-H	Parameter class
Byte	Title	Description										
10	Index-L	Parameter No.										
11	Index-H	Parameter class										
-	011h	Parameter writing	<ul style="list-style-type: none"> Use this to write the parameter value to the servo driver.t Set the parameter number (class, No.) to Index of command. <table border="1" data-bbox="715 981 1270 1102"> <thead> <tr> <th>Byte</th> <th>Title</th> <th>Description</th> </tr> </thead> <tbody> <tr> <td>10</td> <td>Index-L</td> <td>Parameter No.</td> </tr> <tr> <td>11</td> <td>Index-H</td> <td>Parameter class</td> </tr> </tbody> </table> Set the writing value to Setting_Data. Actual written value will be returned to the Monitor_Data of the response. When the parameter was set by the limited value that is different from the command value, WNG bit will be 1. If Index is unsupported parameter number (No. or class is outside of range) or if Setting_Data is other than 0, command error 0032h will be returned. When No. and class are within the range but not supported, command error 0032h will be returned with Setting_Data other than 0. When the bit 0 of Pr.7.23 "RTEX function extended setup 2" is set at 1, the command cannot be executed. And command error 0201h will be returned. Command error 0041h will be returned if you try to a parameter of read only attribute. 	Byte	Title	Description	10	Index-L	Parameter No.	11	Index-H	Parameter class
Byte	Title	Description										
10	Index-L	Parameter No.										
11	Index-H	Parameter class										
-	020h	Parameter initial value read-out *2)	<ul style="list-style-type: none"> The initial value of a parameter is read-out. Set the parameter number (class, No.) to Index of command. <table border="1" data-bbox="715 1554 1270 1675"> <thead> <tr> <th>Byte</th> <th>Title</th> <th>Description</th> </tr> </thead> <tbody> <tr> <td>10</td> <td>Index-L</td> <td>Parameter No.</td> </tr> <tr> <td>11</td> <td>Index-H</td> <td>Parameter class</td> </tr> </tbody> </table> Set Data specified by Pr.7.35 "RTEX command setting 1" as Command_Data3. Return the readout value as Monitor_Data in the response. If Index is unsupported parameter number (No. or class is outside of range) , command error 0032h will be returned. When Pr.7.35 "RTEX command setting 1" is 0, and Command_Data3 is not 0, Command error (0032h) will be returned. 	Byte	Title	Description	10	Index-L	Parameter No.	11	Index-H	Parameter class
Byte	Title	Description										
10	Index-L	Parameter No.										
11	Index-H	Parameter class										

*1) Command error (0031h) will be returned at setting up the wrong type code.

*2) It is not supported in versions corresponding to function extended edition 2 or earlier.

Type_Code *1)		Title	Description									
A4N compatible	standard											
-	030h	The number read-out of the parameters in a classification	<ul style="list-style-type: none"> The number of the parameters in a classification is read. Set the parameter class number to Index-H of command. Fix 0 to Index-L of command. <table border="1"> <thead> <tr> <th>Byte</th> <th>Title</th> <th>Description</th> </tr> </thead> <tbody> <tr> <td>10</td> <td>Index-L</td> <td>Fix 0</td> </tr> <tr> <td>11</td> <td>Index-H</td> <td>Parameter class</td> </tr> </tbody> </table> <ul style="list-style-type: none"> Set Data specified by Pr.7.35 "RTEX command setting 1" as Command_Data3. When Index-L is not 0, Command error (0032h) will be returned. When the classification number in which a parameter does not exist is specified, 0 will be returned. When Index-H is outside the parameter classification number, Command error (0032h) will be returned. When Pr.7.35 "RTEX command setting 1" is 0, and Command_Data3 is not 0, Command error (0032h) will be returned. 	Byte	Title	Description	10	Index-L	Fix 0	11	Index-H	Parameter class
Byte	Title	Description										
10	Index-L	Fix 0										
11	Index-H	Parameter class										
-	040h	Parameter attribute read-out	<ul style="list-style-type: none"> The attribute of a parameter is read-out. Set the parameter number (class, No.) to Index of command. <table border="1"> <thead> <tr> <th>Byte</th> <th>Title</th> <th>Description</th> </tr> </thead> <tbody> <tr> <td>10</td> <td>Index-L</td> <td>Parameter No.</td> </tr> <tr> <td>11</td> <td>Index-H</td> <td>Parameter class</td> </tr> </tbody> </table> <ul style="list-style-type: none"> Set Data specified by Pr.7.35 "RTEX command setting 1" as Command_Data3. When Index is outside the parameter number (No. or class), Command error (0032h) will be returned. When Pr.7.35 "RTEX command setting 1" is 0, and Command_Data3 is not 0, Command error (0032h) will be returned. 	Byte	Title	Description	10	Index-L	Parameter No.	11	Index-H	Parameter class
Byte	Title	Description										
10	Index-L	Parameter No.										
11	Index-H	Parameter class										
101h	081h	EEPROM writing	<ul style="list-style-type: none"> Save the parameter value to EEPROM in the servo driver. (An error might occur during processing. In this case, ERR bit will be 1 instead of command error, and retry to transmit command.) Set 0 to Index of command. Set Data specified by Pr.7.35 "RTEX command setting 1" as Command_Data3. When Index is not 0, Command error (0032h) will be returned. When Pr.7.35 "RTEX command setting 1" is 0, and Command_Data3 is not 0, Command error (0032h) will be returned. When Err. 11.0 "Control power supply under-voltage protection" occurs, command error (0061h) will be returned because of EEPROM accessing failure. When the bit 0 of Pr.7.23 "RTEX function extended setup 2" is set at 1, the command cannot be executed. And command error (0201h) will be returned. 									

*1) Command error (0031h) will be returned at setting up the wrong type code

6-7-2 Parameter number of MINAS-A5N/A6N series

The numbers of parameters used with MINAS-A5N/A6N series are divided into type (major number) and No. (minor number).

The high byte (Index-H) of Index represents the type of parameter and the low byte (Index-L) represents the parameter No.

For example, with Pr.7.23, set it as shown in the table below.

Byte	Title	Description	Setup value (with Pr.7.23)
10	Index-L	Parameter No.	23 (=17h)
11	Index-H	Parameter class	7 (=07h)

These parameters are not compatible with those of MINAS-A4N. To prevent operation error due to incompatible parameters, parameter reading Type_Code and parameter writing Type_Code are changed.

Title	Type_Code	
	MINAS-A4N	MINAS-A5N, A6N
Parameter reading	000h	010h
Parameter writing	001h	011h

When Type_Code is set to 000h or 001h, command error 0031h is returned.

6-7-3 Parameter number of MINAS-A6N series

The not used parameter and the manufacturer's use parameter are also contained in the parameters in a classification read by Type_Code=030h.

Example)

Case of Index-H=08h (When reading the parameter number of the classification 8)

Since 20 parameters (Pr8.00-Pr8.19) exist as shown in the following table, 20 (14h) is returned.

Class	No.	Title
8	00	For manufacturer's use
	01	Profile linear acceleration constant
	02	For manufacturer's use
	03	For manufacturer's use
	04	Profile linear deceleration constant
	05	For manufacturer's use
	06	Not used
	07	Not used
	08	Not used
	09	Not used
	10	Amount of travel after profile position latch detection
	11	Not used
	12	Profile return to home position mode setup
	13	Profile home position return velocity 1
	14	Profile home position return velocity 2
	15	For manufacturer's use
	16	Not used
	17	Not used
	18	Not used
	19	For manufacturer's use

- Please refer to the parameter table of 9-1 clause of Functional Specification for parameters and details other than classification 8.
- Since the not used parameter is not indicated to the parameter table, it is careful.

6-7-4 Parameter attribute of MINAS-A6N series

Attribute indicates when the changed parameter is made valid.

- A: Always valid
- B: Do not change parameter while the motor is operating or command is given.
 - If a parameter is changed while the motor is operating or command is being issued, reflecting timing is not defined.
- C: Made valid, after resetting of control power, in software reset mode of RTEX communication reset command or after execution of attribute C parameter validation mode.
- R: Made valid after resetting of control power or execution of software reset mode of RTEX communication reset command.
 - Not made valid by executing attribute C parameter validation mode of reset command of RTEX communication.
- R0: Read only and cannot be changed through normal parameter changing procedure.

The bit assignment of the parameter attribute read by Type_Code=040h is as follows.

When an applicable bit is 1, it means being the attribute.

	bit7	bit6	bit5	bit4	bit3	bit2	bit1	bit0
Byte12	NOT_USE	(For manufacturer's use)	-	B_AT_INIT	(For manufacturer's use)	-	-	-
Byte13	PARA32BIT	-	-	B_PRM_ATB_CFG	-	-	-	READ_ONLY
Byte14	-	-	-	-	-	-	-	-
Byte15	-	-	-	-	-	-	-	-

- NOT_USE : Not used parameter.
- B_AT_INIT : Made valid after resetting of control power or execution of software reset mode of RTEX communication reset command.
- B_PRM_ATB_CFG : Made valid after execution of attribute C parameter validation mode.
- READ_ONLY : Read only parameter.
- PARA32BIT : 32bit parameter (Parameter whose size is 2 bytes)

Example) Index-H=0, Index-L=8

Since Pr0.08 Command pulse counts per one motor revolution is Attribute C(B_AT_INIT,B_PRM_ATB_CFG) and 32bit parameter(PARA32BIT), "00009010h" is returned

6-7-5 Protecting parameter writing/EEPROM writing through RTEX

Parameter writing or EEPROM writing via RTEX can be inhibited through the setting of bit 0 of Pr.7.23 "RTEX function extended setup 2".

Attempting to access in inhibited status causes returning of command error (0201h).

Pr.7.23 bit 0	Parameter writing/EEPROM writing through RTEX
0	Enable
1	Disable (command error 0201h)

Use this function to prevent the possible problem as described below: the host controller attempts to change parameter while the setup support software PANATERM is running to adjust the gain.

6-8 Profile command (Command code: 17h)

Use this command when starting the operation in profile position control mode (PP) where servo driver internally generates the position command.

This command supports cyclic command only in PP mode (1h).

Set the target position (TPOS) to Command_Data1 field and target speed (TSPD) to Command_Data3 field.

Set the acceleration/deceleration by using parameter Pr.8.01 “Profile linear acceleration constant” and Pr.8.04 “Profile linear deceleration constant”.

Set the operation mode of profile positioning and profile homing by using Type_Code.

For details of these profile operations, refer to 7-5.

Compatible control mode				
NOP	PP	CP	CV	CT
-	○	-	-	-

■ Main command: Common to 16 byte and 32 byte mode

Command		Response	
Byte	bit7 6 5 4 3 2 1 0	Byte	bit7 6 5 4 3 2 1 0
0	C (0) Update_Counter MAC-ID	0	R (1) Update_Counter_Echo Actual_MAC-ID
1	TMG_CNT 17h	1	CMD - Error 17h
2	Control_Bits	2	Status_Flags
3		3	
4	Target_Position (TPOS) [Command unit]	4	Response_Data1
5		5	
6		6	
7		7	
8	Type_Code	8	Type_Code_Echo
9	0	9	ERR WNG 0 Busy PSL/NSL NSL/PSL NEAR Latch_Cmpl
10	0 Latch_Sel1	10	0 Latch_Sel1_Echo
11	Monitor_Sel	11	Monitor_Sel_Echo
12	Target_Speed (TSPD) [Command unit/s] or [r/min]	12	Monitor_Data
13		13	
14		14	
15		15	

■ Sub-command: Only for 32 byte mode

Profile command does not support the sub-command.

Title	Command	Response						
Target_Position (TPOS)	<Absolute positioning mode (with Type_Code = 10h/12h)> Target position [Size]: Signed 32-bit [Unit]: Instruction unit [Setting range]: 8000000h-7FFFFFFFh (-2147483648 to 2147483647)	-						
	<Relative positioning mode (with Type_Code = 11h/13h)> Relative movement distance [[Size]: Signed 32-bit [Unit]: Instruction unit [Setting range]: 8000000h-7FFFFFFFh (-2147483647 to 2147483647)							
	<Non positioning mode> Set to 0.							
Type_Code /Type_Code_Echo	Set operation mode of profile positioning ▪ For details, refer to 6-8-1.	Echo back value of Type_Code						
Latch_Comp1	-	Complete status at latch position 1 ▪ For details, refer to 6-8-3.						
Latch_Sel1 /Latch_Sel1_Echo	<Latch positioning mode> (with Type_Code = 12h/13h)> Select trigger signal of position latch (Ch1) ▪ For details, refer to 6-8-2.	<Latch positioning mode> (with Type_Code = 12h/13h)> Echo back value of Latch_Sel1 ▪ For details, refer to 6-8-2.						
	<Other than latch positioning> Set to 0.	<Other than latch positioning> Echo back value of Latch_Sel1(=0)						
Monitor_Sel /Monitor_Sel_Echo	Select data to be returned to Monitor_Data, by using Type_Code of the monitor command (new 8-bit code for A5N,A6N). ▪ For details, refer to 6-8-3.	Echo back value of Monitor_Sel						
Target_Speed (TSPD) /Monitor_Data	Target speed [Size]: Signed 32-bit [Setting range]: - motor max. speed to motor max. speed ▪ When speed setting is in r/min, it is converted to command unit/s through internal computation and the equivalent value is limited within the range as shown below: -80000001h-7FFFFFFFh (-2147483647-2147483647) ▪ During operation of positioning system (Type_Code = 10h, 11h, 12h, 13h), minimum value of setting range is 0. [Unit]: Set by Pr.7.25 "RTEX speed unit setup"	Monitor data selected by Monitor_Sel ▪ For details, refer to 6-9-1.						
	<table border="1"> <thead> <tr> <th>Pr.7.25</th> <th>Unit</th> </tr> </thead> <tbody> <tr> <td>0</td> <td>[r/min]</td> </tr> <tr> <td>1</td> <td>[Command unit/s]</td> </tr> </tbody> </table>	Pr.7.25	Unit	0	[r/min]	1	[Command unit/s]	
Pr.7.25	Unit							
0	[r/min]							
1	[Command unit/s]							

6-8-1 Profile command Type_Code list

Type_ Code *1)	Title of profile operation mode	Description	Pr.0.01 Control mode setting				
			0: Semi-closed		6: Full-closed		
			SER ABS		SER INC	ABZ INC	SER ABS
			INC	ABS			
10h	Profile absolute positioning	Positioning to the target position (TPOS) specified by absolute position	○	○	○	○	○
11h	Profile relative positioning	Positioning to the target position (TPOS) specified as the relative movement distance from the current internal command position (IPOS)	○	○	○	○	○
12h	Profile Position latch Absolute positioning	Operation starts in latch mode and upon detecting latch trigger, performs positioning by moving from the latch position 1 (LPOS1) to the stop position with the relative distance to the stop position being specified by the parameter setting. ▪ To the target position (TPOS), set the position (absolute position) which is used as stop position when latch trigger is not detected.	○	○	○	○	△ *2)
13h	Profile Position latch Relative positioning	Operation starts in latch mode and upon detecting latch trigger, performs positioning by moving from the latch position 1 (LPOS1) to the stop position with the relative distance to the stop position being specified by the parameter setting. ▪ To the target position (TPOS), set the position which is used as stop position when latch trigger is not detected. Set the stop position by relative movement distance from the current internal command position (IPOS).	○	○	○	○	△ *2)
20h	Profile Continuous revolution (JOG)	Continuous revolution operation without requiring setting of target position (TPOS)	○	○	○	○	○
31h	Profile Homing 1	Homing operation using HOME sensor and Z phase	○	—	○	○	—
32h	Profile Homing 2	Homing operation using HOME sensor	○	—	○	○	—
33h	Profile Homing 3	Homing operation using Z phase	○	—	○	○	—
34h	Profile Homing 4	Homing operation using POT/NOT sensor and HOME sensor	○	—	○	○	—
36h	Profile Homing 6	Homing operation using POT/NOT sensor and Z phase	○	—	○	○	—

○: Supported; △: Partially supported; —: Not supported

*1) If Type_Code error occurs, command error (0031h) will be returned.

*2) As there is no Z-phase in serial communication type absolute external scale, Z-phase cannot be set as the latch trigger. Command error (005Ah) is returned in this case.

Terms in table above	Semi-closed	Full-closed
SER_INC	—	Serial communication type Incremental external scale
ABZ_INC	—	Output type of A, B and Z phases Incremental external scale
SER_ABS	23-bit absolute encoder	Serial communication type Absolute external scale
INC	Incremental mode	—
ABS	Absolute mode	—

6-8-2 Selection of latch trigger signal for positioning profile position latch

For profile position latch absolute positioning (Type_Code = 12h) and profile position latch relative positioning (Type_Code = 13h) use Latch_Sel1 to select the latch trigger signal.

Command		Response	
Byte	bit7 6 5 4 3 2 1 0	Byte	bit7 6 5 4 3 2 1 0
10	0 Latch_Sel1	10	0 Latch_Sel1_Echo

Latch_Sel1	Setting value	Latch trigger signal
Latch_Sel1	0	Z phase *Z-phase of external scale under full-closed *Returns command error (005Ah) for serial communication type absolute external scale.
	1	Logical rising edge of EXT1
	2	Logical rising edge of EXT2
	3	Logical rising edge of EXT3
	4-8	Do not use. *If it chooses, a command error (0032h) will be returned.
	9	Logical falling edge of EXT1
	10	Logical falling edge of EXT2
	11	Logical falling edge of EXT3
	12-15	Do not use. *If it chooses, a command error (0032h) will be returned.

6-8-3 Checking latch mode complete status and latch position data

To check the end status of latch mode at the profile position latch positioning, monitor Latch_Comp1. Latch position 1 can be checked through monitor command.

Command		Response	
Byte	bit7 6 5 4 3 2 1 0	Byte	bit7 6 5 4 3 2 1 0
9	0	9	ERR WNG 0 Busy PSL /NSL NSL /PSL NEAR Latch_Comp1

Latch_Comp1	Description
Latch_Comp1	0: Unlatched at latch position 1 (CH1) 1: Latched at latch position 1 (CH1)

Acquired latch position 1 data can be monitored through Monitor_Data.
Set 09h to Monitor_Sel.

Command		Response	
Byte	bit7 6 5 4 3 2 1 0	Byte	bit7 6 5 4 3 2 1 0
11	Monitor_Sel	11	Monitor_Sel_Echo
12	Command_Data3	12	L
13		13	ML
14		14	MH
15		15	H
			Monitor_Data

Monitor_Sel	Monitor_Data		Description
	Title	Symbol	
09h	Latch position 1	LPOS1	Actual position of motor latched with CH1

6-8-4 Stop command

Profile operation can be stopped or paused by the setting of control bit (Control_Bits).

Byte	Command							
	bit7	6	5	4	3	2	1	0
3	Hard_Stop	Smooth_Stop	Pause	0	SL_SW	0	EX-OUT2	EX-OUT1

Stop command	Description
Hard_Stop (Immediate stop)	<ul style="list-style-type: none"> Setting this bit to 1 in profile control mode immediately stops internal command generation process and ends profile operation. When internal command generation process stops, In_Progress bit is set to 0. In_Progress bit varies depending on set values of Pr4.31 “Positioning complete range”, Pr4.32 “Positioning complete output setup” and Pr4.33 “INP hold time”. *1) Even if this bit is reset to 0, previous operation is not resumed. To restart, change command from 10h to 17h.
Smooth_Stop (Deceleration to stop)	<ul style="list-style-type: none"> Setting this bit to 1 in profile control mode causes deceleration and stop at the rate specified by Pr.8.04 “Profile linear deceleration constant”, ending profile operation. When internal command generation process stops, In_Progress bit is set to 0. In_Progress bit varies depending on set values of Pr4.31 “Positioning complete range”, Pr4.32 “Positioning complete output setup” and Pr4.33 “INP hold time”. *1) Even if this bit is reset to 0, previous operation is not resumed. To restart, change command from 10h to 17h.
Pause (Temporary stop)	<ul style="list-style-type: none"> Setting this bit to 1 in profile control mode causes deceleration and stop at the rate specified by Pr.8.04 “Profile linear deceleration constant”, suspending profile operation. After stopping of internal command generation process, In_Progress bit is maintained at 1. In_Progress bit varies depending on set values of Pr4.31 “Positioning complete range”, Pr4.32 “Positioning complete output setup” and Pr4.33 “INP hold time”. *1) Resetting this bit to 0 during deceleration or stopping resumes previous operation.

*1) For detailed output conditions of In_Position bit, refer to Technical Reference Functional Specification.

6-8-5 Profile positioning neighborhood output (NEAR)

While the profile positioning system is operating (Type_Code = 10h, 11h, 12h, 13h), this output indicates whether the command position is near the target position.

Byte	Command								Byte	Response							
	bit7	6	5	4	3	2	1	0		bit7	6	5	4	3	2	1	0
9	0								9	ERR	WNG	0	Busy	PSL /NSL	NSL /PSL	NEAR	Latch_ Compl

Title	Description
NEAR	<ul style="list-style-type: none"> • Return 1 at location near profile positioning position. • Set the output condition by Pr.7.15 “Positioning adjacent range”. <ul style="list-style-type: none"> ■ Detection range <ul style="list-style-type: none"> -Pr.7.15 <= internal target position - internal command position (IPOS: before filter) <= Pr.7.15

Class	No.	Attribute	parameter Title	Setting range	Unit	Description
7	15	A	Positioning adjacent range	0–1073741823	Command unit	If the difference between internal target position and command position is smaller than the specified value during profile position control (PP), NEAR of RTEX communication status becomes 1.

When the latch trigger signal is detected during profile position latch absolute positioning (12h)/profile position latch relative positioning(13h), the internal target position is updated to the value shown below, not to the value (TPOS) set by the command.

Internal target position = latch position 1 (LPOS1) + Pr.8.10 “Amount of travel after profile position latch detection”

Note that, when deceleration is decreased, for example due to update of internal target position, command position may temporarily exceed internal target position, causing NEAR to turn on.

6-8-6 Software limit (PSL/NSL)

These bits indicate whether the actual position (APOS) exceeds the software limit range during profile position control (PP).

This status can be made valid only with profile command.

Byte	Command								Byte	Response							
	bit7	6	5	4	3	2	1	0		bit7	6	5	4	3	2	1	0
9	0								9	ERR	WNG	0	Busy	PSL /NSL	NSL /PSL	NEAR	Latch_ Compl

Title	Description
PSL	<ul style="list-style-type: none"> Return 1 when actual position (APOS) is larger than Pr7.11 “Positive side software limit value”. <ul style="list-style-type: none"> ■ Detection range Pr7.11 < APOS Use Pr7.10 “Software limit function” to select Valid/Invalid.
NSL	<ul style="list-style-type: none"> Return 1 when actual position (APOS) is smaller than Pr7.12 “Negative side software limit value”. <ul style="list-style-type: none"> ■ Detection range APOS < Pr7.12 Use Pr7.10 “Software limit function” to select Valid/Invalid.

Class	No.	Attribute	parameter Title	Setting range	Unit	Description
7	10	A	Software limit function	0-3	-	Enable or disable software limit function during profile position control (PP). Set the software limit value through Pr.7.11 “Positive side software limit value” and/or Pr.7.12 “Negative side software limit value”. 0: Enable both software limits 1: Disable positive software limit and enable negative software limit 2: Enable positive software limit and disable negative software limit 3: Disable both software limits Note: RTEX communication status is 0 for limit signal (PSL/NSL) disabled by this parameter. It is also 0 when homing is uncompleted.
7	11	A	Positive side software limit value	-1073741823 - 1073741823	Command unit	Set positive side and negative side software limits. When the limit is exceeded, status PSL/NSL of RTEX communication is turned on (= 1).
7	12	A	Negative side software limit value	-1073741823 - 1073741823	Command unit	Note: Make sure that positive side software limit > negative side software limit.

Note that arrangement of status bits may be changed as shown below.

Class	No.	Attribute	parameter Title	Setting range	Unit	Description
7	23	B	RTEX function extended setup 2	-32768 -32767	-	[bit 7] RTEX status bit arrangement setting for PSL/NSL 0: PSL at bit 3 and NSL at bit 2 1: NSL at bit 3 and PSL at bit 2 <ul style="list-style-type: none"> For description on bits other than shown above, refer to Technical Reference Functional Specification “Section 9-1”.

6-8-7 Other precautions related to profile command

- Imports command argument such as Target_Position (TPOS) and starts up when command code changed from 10h to 17h.
- In case of changing command argument and parameter set value in a state of command code 17, there may be cases where values are not reflected or error is given depending on operation status, parameter setting status and arguments to be changed as shown in the following table.

		bit 5 of Pr7.23 (non-cyclic command start-up mode) = 0 (A4N compatible mode)		bit 5 of Pr7.23 (non-cyclic command start-up mode) = 1 (Expansion mode)		
		In operation	In suspension	In operation	In suspension	
Command argument to be changed	Target_Position (TPOS)	Positioning mode (Type_Code=10 – 13h)	△	△	○	△
		Other than positioning mode	–	–	–	–
	Type_Code		×	△	×	△
	Latch_sel1	Latch positioning mode (Type_Code=12h,13h)	×	△	×	△
		Other than latch positioning mode	–	–	–	–
	Monitor_Sel		△	△	○	△
Target_Speed (TSPD)		△	△	○	△	
Parameter to be changed	Pr8.01 “Profile linear acceleration constant”		*	△	*	△
	Pr8.04 “Profile linear deceleration constant”		*	△	*	△
	Pr8.10 “Amount of travel after profile position latch detection”		*	△	*	△
	Pr8.12 “Profile return to home position mode setup”		*	△	*	△
	Pr8.13 “Profile home position return velocity 1”		*	△	*	△
	Pr8.14 “Profile home position return velocity 2”		*	△	*	△

- : Reflected
- △: Not reflected by only change of value
Can be reflected by returning command code to 10h once and by changing it to 17h.
- *: Not reflected
- ×: Change is prohibited
Err91.1 “RTEX command error protection” and command error (0140h) are generated.
- : Invalid

- During operation (In_Progress = 1), non-cyclic commands (except for certain homing commands) can also be executed, maintaining profile operation. However, do not change operation mode (Type_Code and Latch_Sel1 in profile command). Otherwise, Err.91.1 “RTEX command error protection” and command error (0104h) will occur.
- A command error (005Bh) will occur if a profile command (Type_Code=12h, 13h, 31h to 34h, 36h) is received during virtual full-closed control mode.
- A command error (005Bh) will occur if a command to switch to virtual full-closed control mode is received during reception of a profile command (Type_Code=12h, 13h, 31h to 34h, 36h).
- A command error (005Bh) will occur if the code is switched to one other than command code (17h) after a profile command (Type_Code=12h, 13h, 31h to 34h, 36h) is started, or if a command to switch to virtual full-closed control mode is received during the period after profile command start until latch detection or origin detection.

6-9 Monitor Command (Command Code: □Ah)

Use this to read out position error and overload ratio etc.

Compatible control mode				
NOP	PP	CP	CV	CT
-	○	○	○	○

■ Main command: Common to 16 byte and 32 byte mode

Byte	Command								Byte	Response							
	bit7	6	5	4	3	2	1	0		bit7	6	5	4	3	2	1	0
0	C (0)	Update_Counter		MAC-ID					0	R (1)	Update_Counter_Echo		Actual_MAC-ID				
1	TMG_CNT	□Ah							1	CMD_Error	□Ah						
2	Control_Bits								2	Status_Flags							
3									3								
4								L	4								
5	Command_Data1							ML	5	Response_Data1							
6								MH	6								
7								H	7								
8	Type_Code							L	8	Type_Code_Echo							
9	0							H	9	ERR	WNG	0	Busy	H			
10								L	10								
11	Index							H	11	Index_Echo							
12								L	12								
13	Command_Data3							ML	13	Monitor_Data							
14								MH	14								
15								H	15								

■ Sub-command: Only for 32 byte mode

Byte	Command								Byte	Response							
	bit7	6	5	4	3	2	1	0		bit7	6	5	4	3	2	1	0
16	Sub_Chk (1)	0	0	0	Sub_Command_Code (Ah)				16	Sub_CMD_Err	Sub_ERR	Sub_WNG	Sub_Busy	Sub_Command_Code_Echo (Ah)			
17	Sub_Type_Code								17	Sub_Type_Code_Echo							
18								L	18								
19	Sub_Index							H	19	Sub_Index_Echo							
20								L	20								
21	Sub_Command_Data1							ML	21	Sub Monitor_Data							
22								MH	22								
23								H	23								
24								L	24								
25	Sub_Command_Data2							ML	25	Sub_Response_Data2							
26								MH	26								
27								H	27								
28								L	28								
29	Sub_Command_Data3							ML	29	Sub_Response_Data3							
30								MH	30								
31								H	31								

Title	Command	Response
Type_Code /Type_Code_Echo	Specify the monitor to be read ▪ For details, refer to Section 6-9-1.	Type_Code echo back value
Sub_Type_Code /Sub_Type_Code_Echo		Type_Code echo back value
Index/Index_Echo		
Sub_Index /Sub_Index_Echo		
Command_Data3 /Monitor_Data	Data specified by Pr.7.35 "RTEX command setting 1" ▪ For details, refer to Sections 7-7-1.	Specified monitor data [Size]: Signed 32-bit (Sign is dependent on the monitor data) [Unit]: Dependent on the monitor data
Sub_Command_Data1 /Sub_Monirot_Data	Set to 0	▪ If the length of monitor data is 16 bits, it will be converted to 32-bit data before being returned. ▪ Even if the command code and command argument are stored, the monitor data will be updated to the newest value. ▪ For details, refer to Section 6-9-1.

6-9-1 Type code list of monitor command

Type_Code *1)		Title	Index *2)	Unit	Description	Refer to
A4N compatible	standard					
101h	01h	Position deviation	PERR	0 (1,2)	Command unit	6-9-4
<In position control mode> Position deviation <In full-closed control mode> External scale deviation * Method of calculating the position deviation/external scale deviation is defined to change Pr7.23 bit4 "Command positional deviation output setting". (For details, refer to functional specification Section 3-4.)						
				Pr7.23 bit14	Method of calculating the position deviation	
				0	The deviation with respect to the command after the filter	
				1	The deviation with respect to the command before the filter	
<In speed/torque control mode> Undefined Note: Although the same data is returned whether Index is 1 or 2, use Index = 0.						
102h	02h	Encoder resolution	-	0	pulse/r	-
104h	04h	Internal command position (after filtering)	MPOS	0	Command unit	6-9-4
105h	05h	Actual speed	ASPD	0	Set to Pr.7.25	-
Motor actual speed * Set the unit through Pr.7.25 "RTEX speed unit setup".						
				Pr.7.25	Unit	
				0	[r/min]	
				1	[Command unit/s]	
106h	06h	Torque	TRQ	0	0.1%	-
-	07h	Actual position	APOS	0	Command unit	6-9-4
* In full-closed control, the position of external scale						
-	08h	Internal command position (before filtering)	IPOS	0	Command unit	6-9-4
-	09h	Latch position 1	LPOS1	0	Command unit	6-9-4 6-5-4
-	0Ah	Latch position 2	LPOS2	0	Command unit	6-9-4 6-5-4
-	0Ch	Command velocity (after filtering)	MSPD	0	Set to Pr.7.25	-
Command speed after filtering * Set the unit through Pr.7.25 "RTEX speed unit setup".						
				Pr.7.25	Unit	
				0	[r/min]	
				1	[Command unit/s]	
* Value undefined in torque control mode						
-	0Dh	External scale position *4)	EXPOS	0	Pulse (external scale)	-

*1) Upon Type_Code error, command error (0031h) will be returned.

Manufacturer will use a Type_Code not listed above.

When a Type_Code used by the manufacturer is set, undefined value will be returned in place of command error (0031h).

*2) Upon Index error, command error (0032h) will be returned.

*3) A4N compatible Type_Code: Compatible with that for A4N and can be used only with main command.

standard Type_Code: Prepared for A5N,A6N and can be used with both main command and subcommand. When using with main command, set upper 4-bit to 0.

* Although the product supports A4N-compatible Type_Code to maintain compatibility, basically use the standard Type_Code.

*4) It is not supported in versions corresponding to function extended edition 1 or earlier.

Type_Code		Title	Index	Unit	Description	Refer to	
A4N compatible	standard						
111h	11h	Regenerative load ratio	-	0	% *2)	Ratio of the regenerative overload protection to the alarm occurrence level	-
112h	12h	Overload ratio	-	0	0.1%	Ratio of the actual load to the rated motor load	-
-	21h	Logical input signal	-	0	-	Logic level of input signal	6-9-5
-	22h	Logical output signal	-	0	-	Logic level of output signal	6-9-5
-	23h	Logical input signal (expansion portion)	-	0	-	Logic level of input signal (expansion portion)	6-9-5
-	24h	Logical output signal (expansion portion)	-	0	-	Logic level of output signal (expansion portion)	6-9-5
-	25h	Physical input signal	-	0	-	Physical level of input signal	6-9-5
-	26h	Physical output signal	-	0	-	Physical level of output signal	6-9-5
131h	31h	Inertia ratio	-	0	%	The ratio of load inertia to the motor's rotor inertia (equivalent of value in Pr.0.04) Inertia ratio = (load inertia/ rotor inertia) × 100	-
132h	32h	Automatic motor recognition	-	0	-	0: Invalid 1: Valid	-
133h	33h	Cause of no revolution	-	0	-	The number which shows the cause that the motor is not running.	6-9-2
134h	34h	Warning flags	-	0	-	The number which shows the cause that the motor is not running. ▪ The corresponding bit is set to 1 to activate the flag (showing warning status).	6-9-3
-	37h	Multiple alarm/warning information *1)	-	Refer to Section 6-9-6.	-	Information of all alarms and warnings that are occurring now	6-9-6
201h	41h	Mechanical angle (Single turn data)	-	0	pulse	Machine angle of the motor (single-turn data of the absolute encoder) ▪ The value will increase at CCW rotation. Mechanical angle = 0– (Encoder resolution - 1)	-
202h	42h	Electrical angle	-	0	0.7031 degree	Electrical angle of the motor ▪ The value will increase at CCW rotation. Electrical angle = 0–1FF [Hex]	-
-	43h	Multi-turn data	-	0	Turn	Multi-turn data of absolute encoder * Multi-turn data will be an indefinite value under incremental mode (Pr0.15=1).	-
-	44h	Encoder status *1)	-	0	-	Status of encoder	-
-	47h	Sum of encoder pulse counts *1)	-	0	pulse	Sum of encoder feedback pulse counts	-
-	48h	External scale pulse total *1)	-	0	Pulse (external scale)	Total sum of external scale feedback pulses	-
-	49h	External scale absolute position *1)	-	0	Pulse (external scale)	Absolute position of external scale	-
-	61h	Power on cumulative time	-	-	30 min	Cumulative on-time of control power to the servo driver ▪ Because the power on time is recorded in unit of 30 minutes, a turn-on period shorter than 30 minutes is not recorded.	-
-	62h	Servo driver temperature	-	-	°C	Temperature inside the servo driver	-
-	63h	Encoder temperature	-	-	°C	Temperature inside the encoder ▪ Applicable only to 23-bit encoder: 0 for unsupported encoder.	-

*1) It is not supported in versions corresponding to function extended edition 1 or earlier.

*2) Note that it differs from the unit of A4N and A5N. (A4N, A5N: [0.1%], A6N: [%])

* The unit can be switched with Pr7.99 bit7 for function extended edition 3 and later versions.
Pr7.99 bit7 0: [%], 1: [0.1%]

Type_Code		Title	Index	Unit	Description	Refer to	
A4N compatible	standard						
-	64h	No. of inrush resistance relay operations	-	-	Cycle	Operating cycles of inrush current suppression resistor relay <ul style="list-style-type: none"> Saturation will occur at maximum value of 40000000h. Because the power on time is recorded in unit of 30 minutes, a turn-on period shorter than 30 minutes is not recorded. 	-
-	65h	No. of dynamic brake operations	-	-	Cycle	No. of operations of dynamic brake relay <ul style="list-style-type: none"> Saturation will occur at maximum value of 40000000h. Because the power on time is recorded in unit of 30 minutes, a turn-on period shorter than 30 minutes is not recorded. 	-
-	66h	Fan operating time	-	-	30 min	Operating time of cooling fan <ul style="list-style-type: none"> Because the power on time is recorded in unit of 30 minutes, a turn-on period shorter than 30 minutes is not recorded. 0 when no fan is installed. 	-
-	67h	Fan life expectancy	-	-	0.1%	Percent of fan life expectancy. <ul style="list-style-type: none"> Because the power on time is recorded in unit of 30 minutes, a turn-on period shorter than 30 minutes is not recorded. 0 when no fan is installed. 	-
-	68h	Capacitor life expectancy	-	-	0.1%	Percent life expectancy of main power source capacitor <ul style="list-style-type: none"> Because the power on time is recorded in unit of 30 minutes, a turn-on period shorter than 30 minutes is not recorded. 	-
-	69h	Voltage across PN	-	-	V	Main power source PN voltage	-
-	6Ch	Motor power consumption *1)	-	-	W	Instantaneous power consumption of motor	-
-	6Dh	Amount of motor power consumption *1)	-	-	Wh	Amount of motor power consumption	-
-	6Eh	Cumulative value of motor power consumption *1)	-	-	Wh	Cumulative value of motor power consumption	-
401h	71h	RTEX cumulative communication errors	-	0	Cycle	Total number of RTEX communication errors <ul style="list-style-type: none"> Saturation occurs at max. value FFFFh. The count will be cleared upon restarting of servo driver or resetting of control power source. 	-
-	77h	RTEX UpdateCounter accumulated error frequency *1)	-	0	Cycle	Accumulated error frequency of RTEX communication UpdateCounter. <ul style="list-style-type: none"> Saturates at maximum value of FFFFh Cleared by reboot of servo amplifier or reset of control power supply. 	-
-	78h	RTEX communication time out accumulated error frequency *1)	-	0	Cycle	Accumulated frequency of RTEX communication data interrupts and exits. <ul style="list-style-type: none"> Saturates at maximum value of FFFFh Cleared by reboot of servo amplifier or reset of control power supply. 	-
411h	81h	Encoder cumulative communication errors	-	0	Cycle	Total number of communication errors between encoders <ul style="list-style-type: none"> Saturation occurs at max. value FFFFh. The count will be cleared upon restarting of servo driver or resetting of control power source. 	-
413h	83h	External scale accumulated communication error frequency *1)	-	0	Cycle	Accumulated communication error frequency between external scales <ul style="list-style-type: none"> Saturates at maximum value of FFFFh Cleared by reboot of servo amplifier or reset of control power supply 	-
-	84h	External scale accumulated communication data error frequency *1)	-	0	Cycle	Accumulated communication data error frequency between external scales <ul style="list-style-type: none"> Saturates at maximum value of FFFFh Cleared by reboot of servo amplifier or reset of control power supply 	-
-	85h	For manufacturer's use	-	-	-	-	-
-	86h	Hybrid position deviation *1)	-	-	Command unit	Allowance between encoder position and external scale position	-

*1) It is not supported in versions corresponding to function extended edition 1 or earlier.

Type_Code		Title	Index	Unit	Description	Refer to	
A4N compatible	standard						
-	87h	External scale data *1) (Higher 24bit)	-	0	Pulse (external scale)	Higher 24 bits of external scale data	-
-	88h	External scale data *1) (Lower 24bit)	-	0	Pulse (external scale)	<Virtual full-closed control mode invalid> Outputs the lower 24bit of the external scale data. <Virtual full-closed control mode valid> • When AB phase output type scale is connected, position data (16bit) with the position at power supply startup considered as 0 will be output. It is not affected by the direction inversion by Pr3.26. • When serial incremental scale is connected, the position data (24bit) of serial incremental scale will be output. The position data will be the result of direction inversion by Pr3.26.	-
-	89h	External scale status *1)	-	0	-	Status of external scale	-
-	A1h	Velocity control command *1)	-	0	r/min	Velocity control command	-
-	A5h	Internal position command speed *1)	-	0	r/min	Internal position command speed	-
-	A6h	Speed deviation *3)	-	0	r/min	Speed deviation	-
-	A8h	Positive direction torque limit value *1)	-	0	0.05%	Torque limit value in positive direction	-
-	A9h	Negative direction torque limit value *1)	-	0	0.05%	Torque limit value in negative direction	-
-	AAh	Speed limit value *1)	-	0	r/min	Speed limit value	-
-	ABh	Gain switching flag *1)	-	0	-	Gain switching flag	-
-	B1h	Deterioration diagnosis state *1)	-	0	-	Deterioration diagnosis state	-
-	B2h	Deterioration diagnosis torque command average value *1)	-	0	0.1% *2)	Deterioration diagnosis torque command average value	-
-	B3h	Deterioration diagnosis torque command standard value deviation *3)	-	0	0.1%	Deterioration diagnosis torque command standard value	-
-	B4h	Deterioration diagnosis inertia ratio estimate *1)	-	0	%	Deterioration diagnosis inertia ratio estimate	-
-	B5h	Deterioration diagnosis offset load estimate *1)	-	0	0.1% *2)	Deterioration diagnosis offset load estimate	-
-	B6h	Deterioration diagnosis dynamic friction estimate *1)	-	0	0.1% *2)	Deterioration diagnosis dynamic friction estimate	-
-	B7h	Deterioration diagnosis viscous friction estimate *1)	-	0	0.1%/ (10000r/min) *2)	Deterioration diagnosis viscous friction estimate	-

*1) It is not supported in versions corresponding to function extended edition 1 or earlier.

*2) Note that it differs from the unit of the data indicated in the setup support software (PANATERM).

*3) It is not supported in versions corresponding to function extended edition 2 or earlier.

Type_Code		Title	Index	Unit	Description	Refer to																						
A4N compatible	standard																											
-	FAh	Monitor Flags *1)	-	0	-	6-9-7																						
Some flag information of servo driver * Contents of Monitor_Data as response are as follows. <table border="1" data-bbox="896 318 1394 707"> <thead> <tr> <th>Byte</th> <th>bit</th> <th>Description</th> </tr> </thead> <tbody> <tr> <td>12, 20</td> <td>7-0</td> <td>Manufacturer use</td> </tr> <tr> <td>13, 21</td> <td>7-0</td> <td>Manufacturer use</td> </tr> <tr> <td rowspan="3">14, 22</td> <td>7-6</td> <td>Manufacturer use</td> </tr> <tr> <td>5</td> <td>Selection of semi-closed or full-closed 0:semi-closed 1:full-closed</td> </tr> <tr> <td>4</td> <td>Selection of the increment mode or the absolute mode 0: Incremental mode 1: Absolute mode</td> </tr> <tr> <td></td> <td>3-0</td> <td>Manufacturer use</td> </tr> <tr> <td>15, 23</td> <td>7-0</td> <td>Manufacturer use</td> </tr> </tbody> </table>							Byte	bit	Description	12, 20	7-0	Manufacturer use	13, 21	7-0	Manufacturer use	14, 22	7-6	Manufacturer use	5	Selection of semi-closed or full-closed 0:semi-closed 1:full-closed	4	Selection of the increment mode or the absolute mode 0: Incremental mode 1: Absolute mode		3-0	Manufacturer use	15, 23	7-0	Manufacturer use
Byte	bit	Description																										
12, 20	7-0	Manufacturer use																										
13, 21	7-0	Manufacturer use																										
14, 22	7-6	Manufacturer use																										
	5	Selection of semi-closed or full-closed 0:semi-closed 1:full-closed																										
	4	Selection of the increment mode or the absolute mode 0: Incremental mode 1: Absolute mode																										
	3-0	Manufacturer use																										
15, 23	7-0	Manufacturer use																										

*1) It is not supported in versions corresponding to function extended edition 2 or earlier.

6-9-2 Cause of no revolution

Cause of no revolution *1)	Item	Description *2)
0	No cause	Any cause of no revolution cannot be detected. Normally rotates.
1	Not in servo ready state.	<ul style="list-style-type: none"> The main power of the servo driver has not been turned on. Some kind of errors is occurring. Synchronization between communication and servo is not established. Processing in the attribute C parameter validation mode according to the reset command. And other
2	No servo-on command	The Servo On command is not given to the servo driver. <ul style="list-style-type: none"> Servo On bit of Command is 0. EX_ON (external servo-on input) is allocated and the signal is off. And others
3	Over-travel inhibit input active	<ul style="list-style-type: none"> Pr.5.05 = 0,1 Sequence at over-travel inhibit (other than immediate stop) and Pr.5.04 = 0 Over-travel inhibit input active; and positive drive inhibit input (POT) is ON and operation command is positive direction; or, negative drive inhibit input (NOT) is ON and operation command is negative direction. Pr.5.05 = 2 Sequence at over-travel inhibit (immediate stop) and Pr.5.04 = 0 Over-travel inhibit input active; and positive drive inhibit input (POT) is ON and operation command is positive direction or negative drive inhibit input (NOT) is ON, causing the operation to stop, regardless of operation command input.
4, 5	Torque limit value too small	Valid torque limit value is set to 5% or below the rated value.
7	Too low frequency of position command input	Position command per control period is 1 command unit or smaller.
10	Too slow command speed sent through RTEX communication *3)	The command speed sent through RTEX communication is set to 30 [r/min] or smaller.
11	Manufacturer use	—
12	Instruction torque through RTEX communication is low.	The command torque is low: 5% or below the rated torque.
13	Speed limit too low	<ul style="list-style-type: none"> Pr.3.21 Speed limit value is set to 30 r/min or lower when Pr.3.17 = 0. When Pr.3.17 = 1, the speed limit of the parameter (Pr.3.21 or Pr.3.22) specified by SL_SW bit of the command is set 30r/min or lower.
14	Other causes	Above mentioned 1 to 13 causes are not available and the motor doesn't rotate.(Too small commanded value, too heavy load, locking, crashing, servo driver/motor failure, etc.)

*1) Even if any number other than 0, the motor may revolve.

*2) The position command generation process may be interrupted by over-travel inhibit input, resulting in detection of cause 7 instead of cause 3.

*3) It is not supported in versions corresponding to function extended edition 2 or earlier.

6-9-3 Assignment of the warning flag

	bit 7	bit 6	bit 5	bit 4	bit 3	bit 2	bit 1	bit 0
Byte 12	Overload	Fun lock	Regenerative overload	-	-	-	-	Battery
Byte 13	-	-		Main power source off	Update counter	Cumulative communication error	Continuous communication error	Scale error
Byte 14	Deterioration diagnosis	-	-	Scale communication	Oscillation detection	Encoder communication	Encoder overheating	Lifetime detection
Byte 15	-	-	-	-	-	-	-	Execute PANATERM command

6-9-4 Position information during servo off, velocity control and torque control

Position information of command system during servo off, velocity control and torque control varies to follow changes in motor actual position even if the command position from the host controller is stopped.

During servo off, velocity control and torque control, position deviation is undefined.

6-9-5 Status of input and output signals

- Logical input signal

Acquire servo driver logical input signal information.

bit7	6	5	4	3	2	1	0
Enable alarm input (E-STOP)	-	-	-	Positive direction drive inhibit input (POT)	Negative direction drive inhibit input (NOT)	-	Servo on command *1)

bit15	14	13	12	11	10	9	8
-	-	Retreat operation input (RET)	-	-	-	-	Retreat operation stop input (STOP)

bit23	22	21	20	19	18	17	16
-	-	-	-	-	-	-	-

bit31	30	29	28	27	26	25	24
Dynamic break switch input (DB-SEL)	-	-	Safety input 2 (SF2) *2)	Safety input 1 (SF1) *2)	-	-	-

*1) Not external servo on input status but the servo on command for servo control processing.

For details, refer to 4-2-3-1.

*2) It cannot be used in [A6NE].

- Logical input signal (extended portion)

Acquire servo driver logical input signal (extended portion) information.

bit7	6	5	4	3	2	1	0
-	-	-	Near home input (HOME)	-	External latch input 3 (EXT3)	External latch input 2 (EXT2)	External latch input 1 (EXT1)

bit15	14	13	12	11	10	9	8
-	-	-	-	-	-	-	-

bit23	22	21	20	19	18	17	16
-	General purpose monitor input 5 (SI-MON5)	General purpose monitor input 4 (SI-MON4)	General purpose monitor input 3 (SI-MON3)	General purpose monitor input 2 (SI-MON2)	General purpose monitor input 1 (SI-MON1)	-	-

bit31	30	29	28	27	26	25	24
-	-	-	-	-	-	-	-

- Logical output signal

Acquire servo driver logical output signal information.

bit7	6	5	4	3	2	1	0
-	Velocity coincidence output (V-COIN)	Torque limiting output (TLC)	Zero speed detect output (ZSP)	Brake release output (BRK-OFF)	Positioning complete output (INP)	Servo alarm output (ALM)	Servo ready output (S-RDY)

bit15	14	13	12	11	10	9	8
Servo on output (/SRV-ST) *1)	-	-	-	-	Degradation diagnosis speed output (V-DIAG)	At-speed output (AT-SPEED)	-

bit23	22	21	20	19	18	17	16
EDM Output (EDM) *4)	Velocity command on/off output (V-CMD)	Alarm clear attribute output (ALM-ATB)	Velocity limiting output (V-LIMIT)	Positioning complete output 2 (INP2)	Position command on/off output (P-CMD)	Warning output 2 (WARN2)	Warning output 1 (WARN1)

bit31	30	29	28	27	26	25	24
-	STO status monitor output (STO) *2) *3) *4)	-	-	-	-	RTEX operation output 2 (EX-OUT2)	RTEX operation output 1 (EX-OUT1)

*1) 0 indicates the servo ON status and 1 indicates the servo OFF status.

*2) Please refer to the Basic function specification edition for STO status.

*3) STO status monitor output signal is not a safety related part.

*4) It cannot be used in [A6NE].

- Logical output signal (extended portion)

Acquire servo driver logical output signal (extended portion) information.

bit7	6	5	4	3	2	1	0
-	-	-	-	-	-	-	-

bit15	14	13	12	11	10	9	8
-	-	-	-	-	Retreat operation in execution state (RET_STAT)	Communication sync complete output (SYNC_CMP)	-

bit23	22	21	20	19	18	17	16
-	-	-	-	-	-	-	-

bit31	30	29	28	27	26	25	24
-	-	-	-	-	-	-	-

- Physical input signal

Acquire the level of physical input signal to servo driver.

Logic of input signal is 0 when input is open and 1 when it is connected to COM-.

bit7	6	5	4	3	2	1	0
SI8 Input	SI7 Input	SI6 Input	SI5 Input	SI4 Input	SI3 Input	SI2 Input	SI1 Input

bit15	14	13	12	11	10	9	8
-	-	-	-	-	-	-	-

bit23	22	21	20	19	18	17	16
-	-	-	-	-	-	-	-

bit31	30	29	28	27	26	25	24
-	-	-	-	-	-	-	-

- Physical output signal

Acquire the level of physical output signal from servo driver.

Logic of output signal is 0 when output transistor is off and 1 when it is on.

bit7	6	5	4	3	2	1	0
-	-	-	-	-	SO3 Output	SO2 Output	SO1 Output

bit15	14	13	12	11	10	9	8
-	-	-	-	-	-	-	-

bit23	22	21	20	19	18	17	16
-	-	-	-	-	-	-	-

bit31	30	29	28	27	26	25	24
-	-	-	-	-	-	-	-

*1) If Servo on status (SRV-ST) is allocated to the physical output signal, the servo is turned ON in the case of 1 and turned OFF in the case of 0.

*2) When position comparison output (CMP-OUT) is assigned to the PHY output signal, 0 is always set.

6-9-6 Multiple alarm/warning information

The information of alarms and warnings that are currently occurring is indicated to an applicable bit.
Set the alarm/warning information to read out by Index.

Byte	name	Setting value	Information to be read
10	Index-L	00h	Invalid
		01h	Alarm information of alarm main numbers 0 to 31
		02h	Alarm information of alarm main numbers 32 to 63
		03h	Alarm information of alarm main numbers 64 to 95
		04h	Alarm information of alarm main numbers 96 to 127
		11h	Warning information of warning codes A0h to BFh
		12h	Warning information of warning codes C0h to DFh
	Other than the above	Do not use. *It returns the command error (0032h).	
11	Index-H	00h	Invalid
		Alarm main number	Alarm information of the sub number of the set alarm main number

Index-L and Index-H cannot be used at the same time. Be sure to set either Index-L or Index-H to 00h (invalid).
If they are used at the same time, command error (0032h) will be returned.
Refer to Section 6-6-4 for an example of acquiring multiple alarm/warning information.

• Monitor_Data reference table

Index-L	Byte	bit7	6	5	4	3	2	1	0
01h	12	Err7.*	Err6.*	Err5.*	Err4.*	Err3.*	Err2.*	Err1.*	Err0.*
	13	Err15.*	Err14.*	Err13.*	Err12.*	Err11.*	Err10.*	Err9.*	Err8.*
	14	Err23.*	Err22.*	Err21.*	Err20.*	Err19.*	Err18.*	Err17.*	Err16.*
	15	Err31.*	Err30.*	Err29.*	Err28.*	Err27.*	Err26.*	Err25.*	Err24.*
Index-L	Byte	bit7	6	5	4	3	2	1	0
02h	12	Err39.*	Err38.*	Err37.*	Err36.*	Err35.*	Err34.*	Err33.*	Err32.*
	13	Err47.*	Err46.*	Err45.*	Err44.*	Err43.*	Err42.*	Err41.*	Err40.*
	14	Err55.*	Err54.*	Err53.*	Err52.*	Err51.*	Err50.*	Err49.*	Err48.*
	15	Err63.*	Err62.*	Err61.*	Err60.*	Err59.*	Err58.*	Err57.*	Err56.*
Index-L	Byte	bit7	6	5	4	3	2	1	0
03h	12	Err71.*	Err70.*	Err69.*	Err68.*	Err67.*	Err66.*	Err65.*	Err64.*
	13	Err79.*	Err78.*	Err77.*	Err76.*	Err75.*	Err74.*	Err73.*	Err72.*
	14	Err87.*	Err86.*	Err85.*	Err84.*	Err83.*	Err82.*	Err81.*	Err80.*
	15	Err95.*	Err94.*	Err93.*	Err92.*	Err91.*	Err90.*	Err89.*	Err88.*
Index-L	Byte	bit7	6	5	4	3	2	1	0
04h	12	Err103.*	Err102.*	Err101.*	Err100.*	Err99.*	Err98.*	Err97.*	Err96.*
	13	Err111.*	Err110.*	Err109.*	Err108.*	Err107.*	Err106.*	Err105.*	Err104.*
	14	Err119.*	Err118.*	Err117.*	Err116.*	Err115.*	Err114.*	Err113.*	Err112.*
	15	Err127.*	Err126.*	Err125.*	Err124.*	Err123.*	Err122.*	Err121.*	Err120.*
Index-L	Byte	bit7	6	5	4	3	2	1	0
11h	12	WngA7h	WngA6h	WngA5h	WngA4h	WngA3h	WngA2h	WngA1h	WngA0h
	13	WngAFh	WngAEh	WngADh	WngACh	WngABh	WngAAh	WngA9h	WngA8h
	14	WngB7h	WngB6h	WngB5h	WngB4h	WngB3h	WngB2h	WngB1h	WngB0h
	15	WngBFh	WngBEh	WngBDh	WngBCh	WngBBh	WngBAh	WngB9h	WngB8h
Index-L	Byte	bit7	6	5	4	3	2	1	0
12h	12	WngC7h	WngC6h	WngC5h	WngC4h	WngC3h	WngC2h	WngC1h	WngC0h
	13	WngCFh	WngCEh	WngCDh	WngCCh	WngCBh	WngCAh	WngC9h	WngC8h
	14	WngD7h	WngD6h	WngD5h	WngD4h	WngD3h	WngD2h	WngD1h	WngD0h
	15	WngDFh	WngDEh	WngDDh	WngDCh	WngDBh	WngDAh	WngD9h	WngD8h
Index-H	Byte	bit7	6	5	4	3	2	1	0
*	12	Err*.7	Err*.6	Err*.5	Err*.4	Err*.3	Err*.2	Err*.1	Err*.0
	13	Err*.15	Err*.14	Err*.13	Err*.12	Err*.11	Err*.10	Err*.9	Err*.8
	14	Err*.23	Err*.22	Err*.21	Err*.20	Err*.19	Err*.18	Err*.17	Err*.16
	15	Err*.31	Err*.30	Err*.29	Err*.28	Err*.27	Err*.26	Err*.25	Err*.24

*The table above includes the alarm numbers and warning numbers that do not exist.

6-9-7 Function for reading control mode and absolute setting

This function notifies the host device of the control mode (semi-closed/full-closed) and the absolute setting (increment mode/absolute mode) that the driver currently recognizes by using Type_Code=FAh (monitor flags) of the monitor command (□Ah).

Use this function to confirm from the host device that the current parameter setting coincides with the setting that the servo driver recognizes.

The read value is output as the response data (Byte14, 22) of the monitor flag in accordance with the table below.

bit4 = 0 (increment mode)

bit4 = 1 (absolute mode)

bit5 = 0 (semi-closed control)

bit5 = 1 (full-closed control)

Control mode setup (Pr0.01)	Encoder type	External scale selection (Pr3.23)	Absolute encoder setup (Pr0.15)	Setting value read result (Response Data)			
				Byte14,22			
				bit7~6	bit5	bit4	bit3~0
semi-closed control (Pr0.01=0)	23bit Absolute	—	Use as an absolute mode (Pr0.15=0,2,3,4)	Manufacturer use	0	1	Manufacturer use
			Use as an incremental mode (Pr0.15=1)	Manufacturer use	0	0	Manufacturer use
Full-closed control (Pr0.01=6)	—	A/B/Z phase signal differential output type (Pr3.23=0)	—	Manufacturer use	1	0	Manufacturer use
		Serial communication type (Incremental) (Pr3.23=1)	—	Manufacturer use	1	0	Manufacturer use
		Serial communication type (Absolute) (Pr3.23=2)	—	Manufacturer use	1	1	Manufacturer use

6-10 Command error (Command code: □□h)

If the servo driver cannot receive a command due to its incompleteness, it returns this response in which bit 7 of Byte 1 is 1.

■ Main command: Common to 16 byte and 32 byte mode

	Command									Byte	Response								
	Byte	bit7	6	5	4	3	2	1	0		Byte	bit7	6	5	4	3	2	1	0
Cyclic	0	C (0)	Update_Counter		MAC-ID					0	R (1)	Update_Counter_Echo		Actual_MAC-ID					
	1	TMG_ CNT	Command_Code (□□h)							1	CMD_ Error (1)	Command_Code_Echo (□□h)							
	2	Control_Bits							2	Status_Flags									
	3								3										
	4	<Command_Data1> Dependent on cyclic command							L	4	<Response_Data1> Default: Actual_Position (APOS) [Command unit]							L	
	5								ML	5								ML	
	6								MH	6								MH	
7	H								7	H									
Non-cyclic	8	<Command_Data2> Dependent on non-cyclic command							L	8	Error_Code							L	
	9								ML	9								H	
	10								MH	10	L								
	11								H	11	H								
	12	<Command_Data3> Dependent on non-cyclic command							L	12	0							L	
	13								ML	13								ML	
	14								MH	14								MH	
15	H								15	H									

■ Sub-command: Only for 32 byte mode

Byte	Command									Byte	Response								
	bit7	6	5	4	3	2	1	0	bit7		6	5	4	3	2	1	0		
16	Sub_ Chk (1)	0	0	0	Sub_Command_Code (Ah)					16	Sub_ CMD_ Err	Sub_ ERR	Sub_ WNG	Sub_ Busy	Sub_Command_Code_Echo				
17	Sub_Type_Code									17	0								
18	Sub_Index							L	18	Sub_Error_Code							L		
19								H	19								H		
20	Sub_Command_Data1							L	20	0							L		
21								ML	21								ML		
22								MH	22								MH		
23								H	23								H		
24	Sub_Command_Data2							L	24	Sub_Response_Data2							L		
25								ML	25								ML		
26								MH	26								MH		
27								H	27								H		
28	Sub_Command_Data3							L	28	Sub_Response_Data3							L		
29								ML	29								ML		
30								MH	30								MH		
31								H	31								H		

Title	Command	Response
CMD_Error /Sub_CMD_Error	–	Return 1.
Error_Code /Sub_Error_Code	–	Command error code ▪ For details, refer to Sections 6-10-1 and 6-10-2.

6-10-1 Command error detection

When command error occurs, the servo driver cannot receive the command and perform required process.
Build a system which either will not generate an error or will not enter unsafe status even if an error occurs.

6-10-1-1 Command error common to 16-byte and 32-byte modes

Field where error is detected		Error content	Command data valid ○/invalid × (If invalid, the previous data is used.)							Error_Code *5)	Alarm	
			Command code *1)		Cyclic data		Non-cyclic data					
Byte	bit		Byte1		Byte 2-3	Byte 4-7	Byte 8-11	Byte 12-15 (FF invalid) *8)	Byte 12-15 (FF valid) *8)			
			bit 6-4	bit 3-0								
0	4-0	Mismatched node address (MAC-ID) *2)	×	×	×	×	×	×	×	0011h	Err86.0	
	7	C/R bit is 1 despite of command *2)	×	×	×	×	×	×	×	0012h		
1	6-4	Undefined cyclic command *2)	×	×	×	×	×	×	×	0021h	Err86.1	
		Cyclic command error (except for undefined error) *7)	×	×	×	×	×	×	×	002Eh	Err91.1	
	3-0	Undefined non-cyclic command *3)	○ *4)	×	○	○	×	×	○	0022h	No occurrence	
2	6	Corresponds to exclusive condition for virtual full-closed control mode *9)	×	×	×	×	×	×	005Bh			
2	except 6	(Unused bit is 1)	No error checked									
3	-	(Unused bit is 1)										
4-7	-	Cyclic data (Command_Data1 is outside the setting range, etc. *5)	○	○	○	×	○	○	○	Code corresponding to the error ▪ See 6-10-2.		
8-11	-	Non-cyclic data (Command_Data 2) is outside the setting range. *6)	○	○	○	○	×	×	○			
12-15 (FF invalid)	-	Non-cyclic data (Command_Data 3) is outside the setting range. *6)	○	○	○	○	×	×	-			
12-15 (FF valid)	-	Non-cyclic data (Command_Data 3) is outside the setting range. *6)	○	○	○	○	○	-	×			

*1) Even if command code of byte 1 is invalid, the same value will be echo-backed in response.

*2) Command error (0021h) will be returned if cyclic command (Byte 1, bits 6-4) is not defined; command error (0011h) will be returned if node address does not match; command error (0012h) will be returned if C/R bit is 1. These cause unsafe condition due to lack of cyclic transfer: if error condition lasts for specified period, Err86.1 “RTEX cyclic data error protection 2” generates an alarm.

*3) Command error (0022h) will be returned when cyclic command (bits 6 to 4 at Byte 1) is complete and non-cyclic command (bits 3 to 0 of Byte 1) is not defined.

*4) Only cyclic command (bits 6 to 4 at Byte 1) will be valid when non-cyclic command (bits 3 to 0 of Byte 1) is not defined.

*5) When cyclic data (Byte 4 to 7) is outside the setting range, the command error (0033h) will occur and the previous value will be used for operation. If previous cyclic command (Byte 1, bits 6-4) was different, causing the previous value undefined, set the value to 0.

- *6) When non-cyclic data (byte 8 to 15) is abnormal, error code corresponding to the error content will be returned. For details of error code, refer to 6-10-2.
- *7) Command error (002Eh) will be returned if the defined cyclic command (Byte 1, bits 6-4) is not correctly received. This causes unsafe condition due to lack of cyclic transfer and Err91.1 “RTEX command error protection” generates alarm.
- *8) “FF invalid” means that Command_Data3 feedforward is invalid and “FF valid” means feedforward is valid.
- *9) A command error (005Bh) is returned when the result is exclusive condition after executing check on exclusive function with virtual full-closed control mode.
Please refer to error code 005Bh in Section 6-10-2 for exclusive conditions.

6-10-1-2 Command error in 32-byte mode

Field where error is detected		Error content	Subcommand data – valid ○/invalid × (If invalid, use the previous command.)					Sub_Error_Code *5)	Alarm
			Sub_Chk	Subcommand code *1)	Subcommand data				
Byte	bit		Byte16		Byte17 –23	Byte24 –27	Byte28 –31		
			bit7	bit 3–0					
16	7	Sub_Chk bit is 0 in 32-byte mode. *2)	×	×	×	×	×	0012h	Err86.0
	3–0	Subcommand is undefined. *3)	○	×	×	○	○	0022h	
17–23	-	Subcommand data (Sub_Type_Code, Sub_Index, Sub_Command_Data1) is outside the setting range, etc. *5)	○	○	×	○	○	Code corresponding to the error	No occurrence
24–27	-	Feedforward data 2 (Sub_Command_Data2) is outside the setting range. *4)	○	○	○	×	○	0034h	
28–31	-	Feedforward data 3 (Sub_Command_Data3) is outside the setting range. *4)	○	○	○	○	×		

*1) Even if the subcommand code of Byte 16 is invalid, the value is echoed back in response.

*2) When Sub_Chk bit is 0, subcommand error (0012h) will be returned. This is interpreted as whole command (Bytes 0–31) in 32-byte mode is incorrect, and if error condition lasts for predetermined period, Err86.0 “RTEX cyclic data error protection 1” causes an alarm. And when subcommand error (0012h) will be returned, main command cannot execute required process.

*3) Even if subcommand (Byte 16, bits 3–0) is undefined, feedforward data 2/3 (Bytes 24–31) are made valid.

*4) When feedforward data is outside the setting range, command error (0034h) is generated and the previous value is used for operation.

*5) When the value of subcommand data (Bytes 17–23) is not correct, corresponding Sub_Error_Code will be returned.

For details of any other Sub_Error_Code, see 6-10-2.

6-10-2 List of command error code

Category	Error_Code	Cause
Command header related	0011h	• Mismatched node address (MAC-ID)
	0012h	• C/R bit is 1 despite of command • Sub_Chk is 0 in 32-byte mode.
Command code, control mode related	0021h	• Cyclic command is not defined
	0022h	• Non-cyclic command is not defined (when cyclic command is normal) • Combination error of control mode and non-cyclic command. • Subcommand is undefined in 32-byte mode.
	002Eh	• Combination of communication cycle, semi-closed/full-closed, 16/32-byte mode and control mode is not correct. • Control mode has been changed by less than 2 ms. • Control mode has been changed during profile position latch positioning/profile homing (Type_Code = 12h, 13h, 31h, 32h, 33h,34h,36h) operation. • Control mode has been changed during execution of non-cyclic command (Busy = 1). • Run the home return command (□4h) Type_Code=1□h/2□h during the velocity control (CV)/torque control (CT) • Switched to velocity control while in two degree-of-freedom control (synchronous) mode. • Switched to torque control while in two degree-of-freedom control (standard/synchronous) mode. • Control mode was switched during retreat operation.
Argument related	0031h	• Type_Code/Sub_Type_Code is not defined.
	0032h	• Non-cyclic data/subcommand data other than Type_Code/Sub_Type_Code is out of setup range.
	0033h	• Cyclic data (command_data1) is out of setup range
	0034h	• Feedforward data (Command_Data3, Sub_Command_Data2/3) is out of setup range.
Not executable 1 (general)	0041h	• Write access is attempted to read only media.
	0042h	• Alarm clear command is executed while an alarm that cannot be cleared and no warning is issued.
	0043h	• Executed external scale error clear command when not in full closed control mode or when external scale error has not occurred.
	0045h	• In servo on state, reset command is executed in attribute C parameter validation mode.
	0046h	• After deceleration and stop according to the drive inhibit input (POT/NOT), direction command POT/NOT is applied. • During deceleration according to the drive inhibit input (POT/NOT), a profile operation (except for Type_Code = 31h, 32h, 33h,34h,36h) is started.
Not executable 2 (Related to return-to-home)	0051h	• Return-to-home command, multi-turn clear, is executed while the encoder is in the incremental mode. • Multi-turn clearing of the home position return command was executed even when the single-turn absolute function was effective.
	0052h	• During cyclic position control (CP) (* including full-closed control) in absolute mode, Type_Code = 1□h of homing command(□4h) has been executed. • During profile position control (PP) (* including full-closed control) in absolute mode, profile homing has been executed.
	0053h	• During cyclic position control (CP) (* including full-closed control) in absolute mode, actual position set/command position set (Type_Code = 21h, 22h) of homing command (□4h) have been executed.
	0055h	• Executed multi-rotation clear of return to origin command, even though it was under full closed mode.
	0056h	• Return-to-home command, multi-turn clear, is executed while in the servo-on condition.
	0057h	• Return-to-home command, Type_Code = 1□h, is executed while in the servo-off condition.
	0058h	• While the external input is not assigned to the latch correct terminal, Type_Code is executed by using the external input as a trigger. • Latch mode with stop function is started using the amplifier output signal as the trigger signal with Pr7.111 "Trigger signal assignment setup for latch mode with stop function"=0 "invalid."
	0059h	• During profile position latch positioning/profile homing (Type_Code = 12h, 13h, 31h, 32h, 33h,34h,36h), homing command (□4h) has been executed. • During profile positioning/profile continuous revolution (Type_Code = 10h, 11h, 20h) homing command (□4h) of initialization mode (Type_Code=1□h, 31h) has been executed.
	005Ah	• Z-phase has been set as latch trigger signal even though it is an absolute external scale.

(To be continued)

Category	Error_Code	Cause
Not executable 2 (Related to return-to-home)	005Bh	<ul style="list-style-type: none"> • Reception of one of the following commands under virtual full-closed control mode state <ul style="list-style-type: none"> - Return to origin command (□4h) - Latch absolute positioning (12h) at profile position in profile command (17h) - Latch absolute positioning (13h) at profile position in profile command (17h) - Profile return to origin (31h to 34h, 36h) of profile command (17h) - Config command • Reception of the command to switch to virtual full-closed control mode under one of the following states <ul style="list-style-type: none"> - Initialization mode operation, latch mode operation, or latch mode operation with stop function for of return to origin command (□4h) - Switching to a code other than command code (□4h) after starting return to origin command (Type_Code: 51h to 53h) - Period from latch startup until latch detection after starting return to origin command (Type_Code: 51h to 53h) - Operation of latch absolute positioning (12h) at profile position in profile command (17h) - Operation of latch absolute positioning (13h) at profile position in profile command (17h) - Operation of profile return to origin (31h to 34h, 36h) of profile command (17h) - Period after starting a profile command (12h, 13h, 31h to 34h, 36h) until latch detection or origin detection while also being switched to a code other than command code (17h) - During execution of Config command
	005Fh	<ul style="list-style-type: none"> • For settings other than cyclic position control (CP), latch mode with stop function (Type_Code= F1h) is used. • For settings other than communication cycle 0.5 ms/command update cycle 1.0 ms, latch mode with stop function (Type_Code= F1h) is used. • For a setting in which electronic gear ratio is smaller than 1, latch mode with stop function (Type_Code= F1h) is used.
Not executable 3 (related to hardware factor)	0061h	<ul style="list-style-type: none"> • “EEPROM writing” is not permitted because of under voltage of the control power
Not executable 4 (in process)	0101h	<ul style="list-style-type: none"> • In processing the previous command
	0102h	<ul style="list-style-type: none"> • Command is not permitted to be accepted because the servo driver is accessing to the encoder now
	0103h	<ul style="list-style-type: none"> • Command is not permitted to be accepted because the servo driver is accessing to the external scale now
	0104h	<ul style="list-style-type: none"> • Type_Code has been changed while operating under profile position control (PP).
	0105h	<ul style="list-style-type: none"> • RTEX command (reset command, home homing command, or parameter command) was received during execution of PANATERM command (test run operation, FFT, Z phase search, pin assignment setting, or fit gain).
Not executable 5 (access inhibit)	0201h	<ul style="list-style-type: none"> • Command is not permitted to be accepted because parameter writing or writing to EEPROM is inhibited now • Write parameter command or write EEPROM command is issued while bit 0 of Pr.7.23 “RTEX function extended setup 2” is set at 1.

6-11 Communication Error (Command code: □□h/ Response code: FFh)

This response will be returned when the communication error (CRC error) has been detected by the servo driver. Then the servo driver continues controlling based on the previously received command.

	Byte	Command								Byte	Response									
		bit7	6	5	4	3	2	1	0		bit7	6	5	4	3	2	1	0		
Cyclic	0	C (0)	Update_Counter		MAC-ID						0	R (1)	Update_Counter _Echo		Actual_MAC-ID					
	1	TMG_ CNT	Command_Code (□□h)								1	FFh								
	2	Control_Bits								2	Status_Flags									
	3									3										
	4	<Command_Data1> Dependent on cyclic command								L	4	<Response_Data1> Default: Actual_Position (APOS) [Command unit]								
	5									ML	5									
	6									MH	6									
7	H									7										
Non-cyclic	8	<Command_Data2> Dependent on non-cyclic command								L	8	0								
	9									ML	9									
	10									MH	10									
	11									H	11									
	12	<Command_Data3> Dependent on non-cyclic command								L	12	0								
	13									ML	13									
	14									MH	14									
15	H									15										

■ Sub-command: Only for 32 byte mode

Byte	Command								Byte	Response								
	bit7	6	5	4	3	2	1	0		bit7	6	5	4	3	2	1	0	
16	Sub_ Chk (1)	0	0	0	Sub_Command_Code (Ah)				16	1	0	0	0	Fh				
17	Sub_Type_Code								17	0								
18	Sub_Index								L	18	0							
19									H	19								
20	Sub_Command_Data1								L	20	0							
21									ML	21								
22									MH	22								
23									H	23								
24	Sub_Command_Data2								L	24	Sub_Response_Data2							
25									ML	25								
26									MH	26								
27									H	27								
28	Sub_Command_Data3								L	28	Sub_Response_Data3							
29									ML	29								
30									MH	30								
31									H	31								

Title	Command	Response
Byte1	–	Return FFh
Byte6	–	Return 8Fh

When the communication error (CRC error) occurs continuously, the servo amplifier shows Err83.0 “RTEX communication error protection 1”.

Number of alarm generation can be set by the following parameter.

Class	No.	At- trib- ute	Title	Range	Unit	Description
7	95	R	Number of RTEX continuous communication error protection 1 detections	0-17	No. of times	Set the number of RTEX continuous communication error protection 1 detections. If a continuous CRC error occurs exceeding the number of times set for this parameter, Err83.0 “RTEX continuous communication error protection 1” occurs. If 0 or 1 is set for this parameter, 2 is internally set.

7. Operation

7-1 Cyclic position control (CP) operation

When the cyclic command (Byte 1, bits 6–4) is 2h while in the semi-closed or full-closed control mode and in servo-on condition (Servo_Active: response Byte 2, bit 7 is 1), perform positioning operation according to the given command position (absolute position: Bytes 4–7).

However, if the command position (absolute position: Byte4 to 7) input when the single-turn absolute function is effective has become out of the setting range, command error (0033h) will be returned.

For details of the command position setting range, refer to Technical Reference Functional Specification "Section 6-2-2".

You have to pay attention to the following.

7-1-1 Command follow-up process (command position at servo-off)

For the cyclic positioning (CP), position command is given as absolute position.

Therefore, if the actual position is changed by an external force, the position will return back to the command position upon the next servo-on if the command position is kept. This operation may cause Err. 27.7 "Command error protection" or Err. 26.0 "Over-speed protection" in certain condition. Do not apply the movement command during servo-on, even if the direction is drive inhibit input.

Therefore, for the sake of safety, be sure to have the command position set up with the actual position value read from the servo driver when in the servo off condition (have the actual position tracked by the command position).

Be sure to judge the servo off condition for this processing by whether or not the response Servo_Active is 0.

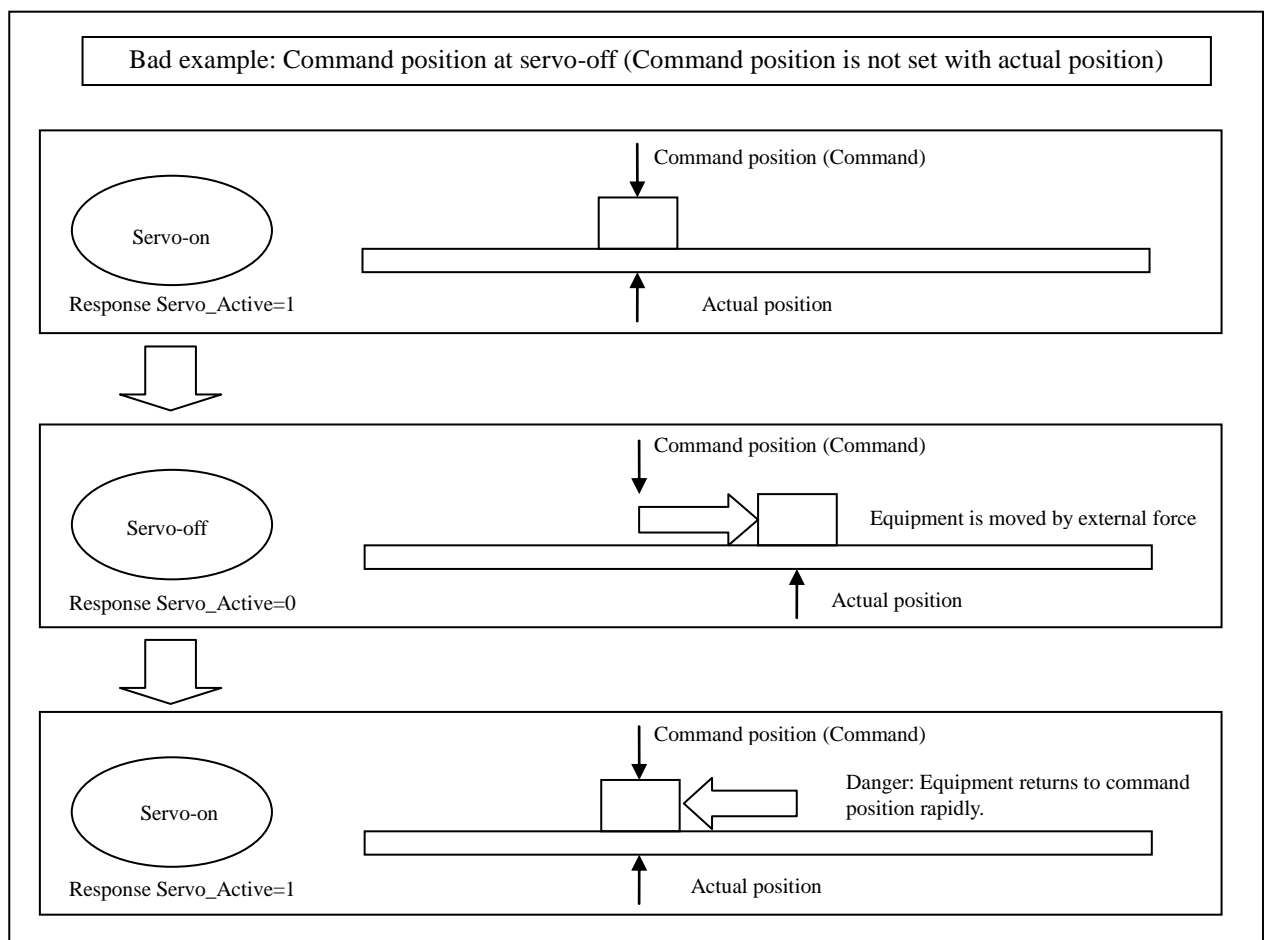

7-1-2 Prohibited matter of NOP command (0□h)

NOP command (0□h) is designed to be used for transient transmission while “the data to be transmitted is not yet prepared” due to processing timing problem until network is established. Therefore, try to transmit regular command e.g. 20h that specifies control mode, as soon as possible and never try to transmit NOP, and not to try to retransmit NOP.

If NOP command is transmitted while the motor is running in the cyclic positioning (CP) operation, the servo driver controls at the command position determined by the previously received command, and the cycle is unchanged as if the stop command is received. Never transmit NOP command which causes unstable operation.

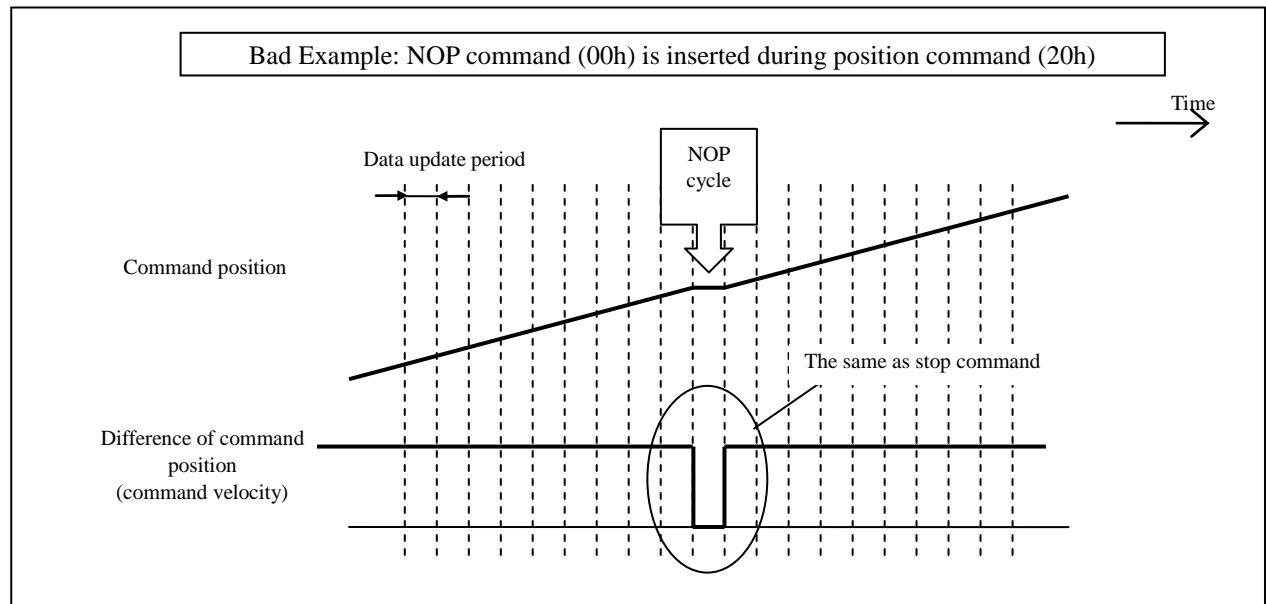

7-1-3 Command position upon communication error

If communication error (CRC error, missing data, cyclic data error) occurs during CP control, control the command position at the estimated position.

7-1-4 Variations in command position during command updating period

7-1-4-1 Limiting variations in command position

When applying the movement command, make sure that variations in command position during command updating period will not exceed the motor maximum speed.

If a variation of command position during communication period is too large, Err27.4 “Command error protection” will be activated.

7-1-4-2 Wrap rounding command position

If a variation of command position during communication period has exceeded the following values, wraparound process starts.

Absolute encoder setup	Wraparound threshold [command unit]	
	lower limit	upper limit
Infinitely rotatable absolute encoder mode	0	$(2^{23} * \text{Pr6.88 setting value}) - 1$
Other than infinitely rotatable absolute encoder mode	80000000h	7FFFFFFFh

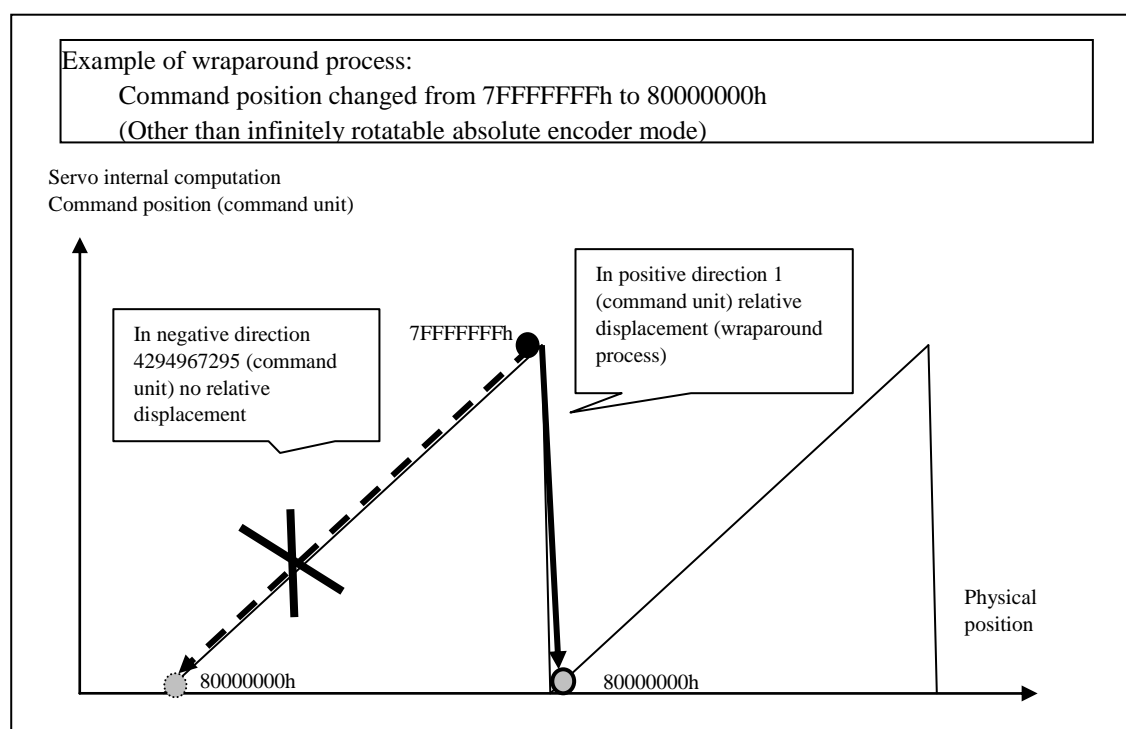

7-1-4-3 Clearing position deviations

When clearing position deviations from the host controller, read the actual position (APOS) and set command position to the value so that actual position (APOS) becomes equal to command position (CPOS).

Note that, as in the case of 7-1-4-1, change the command position (CPOS) gradually by dividing the command updating period in several sub-periods so that variations in command position will not exceed the limit.

7-1-4-4 Amount of change saturation function of command position

This function is to prevent from Err27.4 triggered by abnormal input command which is caused by input command calculation delay from master controller.

For the sake of motor operation stabilization, the amount of position command difference is saturated by the converted value from motor maximum velocity.

(1) Applicable Range

This function operates under the following conditions.

Conditions that command position saturation function to operate	
Control mode	• Position control
Others	• Should be in servo-on condition • Parameters except for controls such as torque limit setup, are correctly set, assuring that the motor can run smoothly. • It is a Pr7.22 bit5 = 1 (Valid)

(2) Caution

- By enabling this function, when the unexpected position command is received, the servo amplifier can suppress Err27.4 “Comman Error Protection”.

In case of using this function, please consider well how the master controller behaves.

(3) Relevant parameters

Class	No.	At-tribute	Title	Range	Unit	Function
7	22	R	RTEX function extended setup 1	-32768 -32767	—	[bit5] Command pulse saturation function selection 0: Invalid 1: Valid (Saturated with motor maximum speed)

(4) Example of movement (CP control)

1. When invalid the amount of change saturation function of command position (Pr7.22 bit5=0)

As shown below, when the master controller updates RTEX command position less timing than the command update cycle, the difference of command position would become large at the timing of update period of RTEX command position. Below shows 3 times faster.

Therefore, as the amount of change is larger than that of expected value, Err27.4 would be easy to occur.

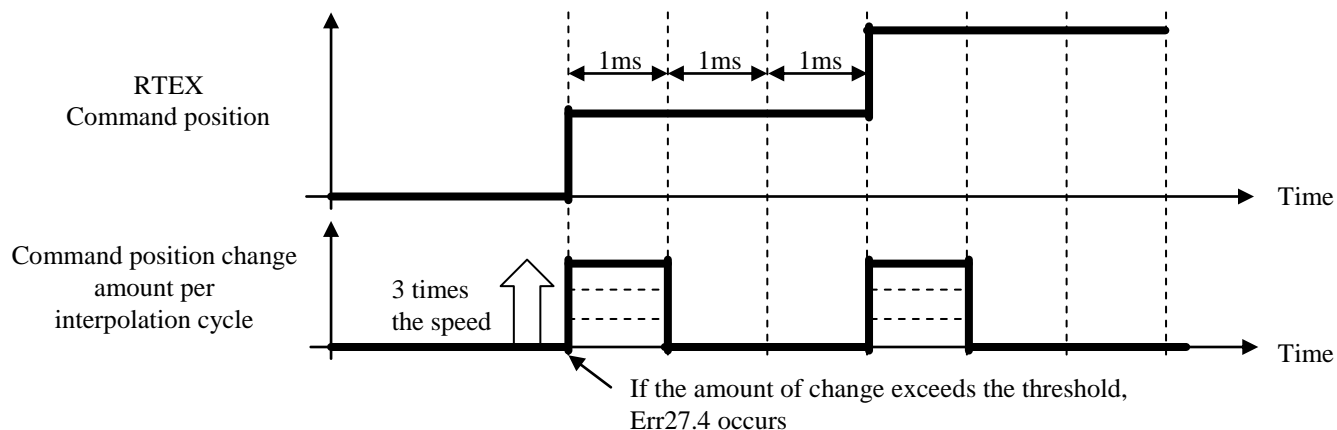

2. When valid the amount of change saturation function of command position (Pr7.22 bit5=1)

In case that the amount of RTEX command position change becomes over motor maximum velocity, the change of command position per command update cycle is saturated at the motor maximum velocity. By this function, even if the master controller sends the abnormal position command, Err27.4 wouldn't be generated and the motor operation would become stable.

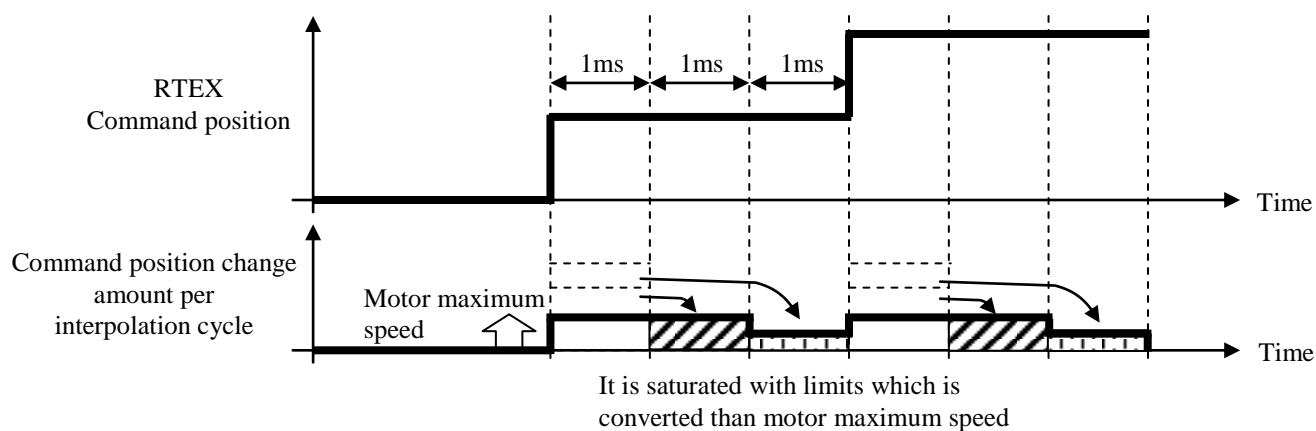

7-2 Homing operation

When using the unit in incremental mode, homing is required before positioning after power up, software reset or execution of attribute C parameter validating mode.

With MINAS-A6N, the following return-to-home sequences can be used.

Sequence	Description
Cyclic homing	The host controller controls the return-to-home sequence in cyclic position control (CP) mode.
Profile homing	The servo driver controls the return-to-home sequence in profile position control (PP) mode.

For profile homing, refer to 7-5.

Note: Return-to-home (except for multi-turn data clear of absolute encoder) cannot be started in the velocity/torque control mode.

Switch to the cyclic position control (CP) mode or profile position control (PP) mode and start the homing operation and then return back to the previous control mode.

7-2-1 Normal return-to-home sequence in cyclic position control (CP) mode

[Type_Code: 011h-01Dh]

The figure below shows the return-to-home sequence using the trigger signal (logical rising or falling edge of sensor or Z-phase).

Initialize the position information so that Homing_Ctrl bit is 1 and trigger detection position is zero. When Homing_Ctrl bit is 0, the position information is not initialized upon detecting of the trigger signal.

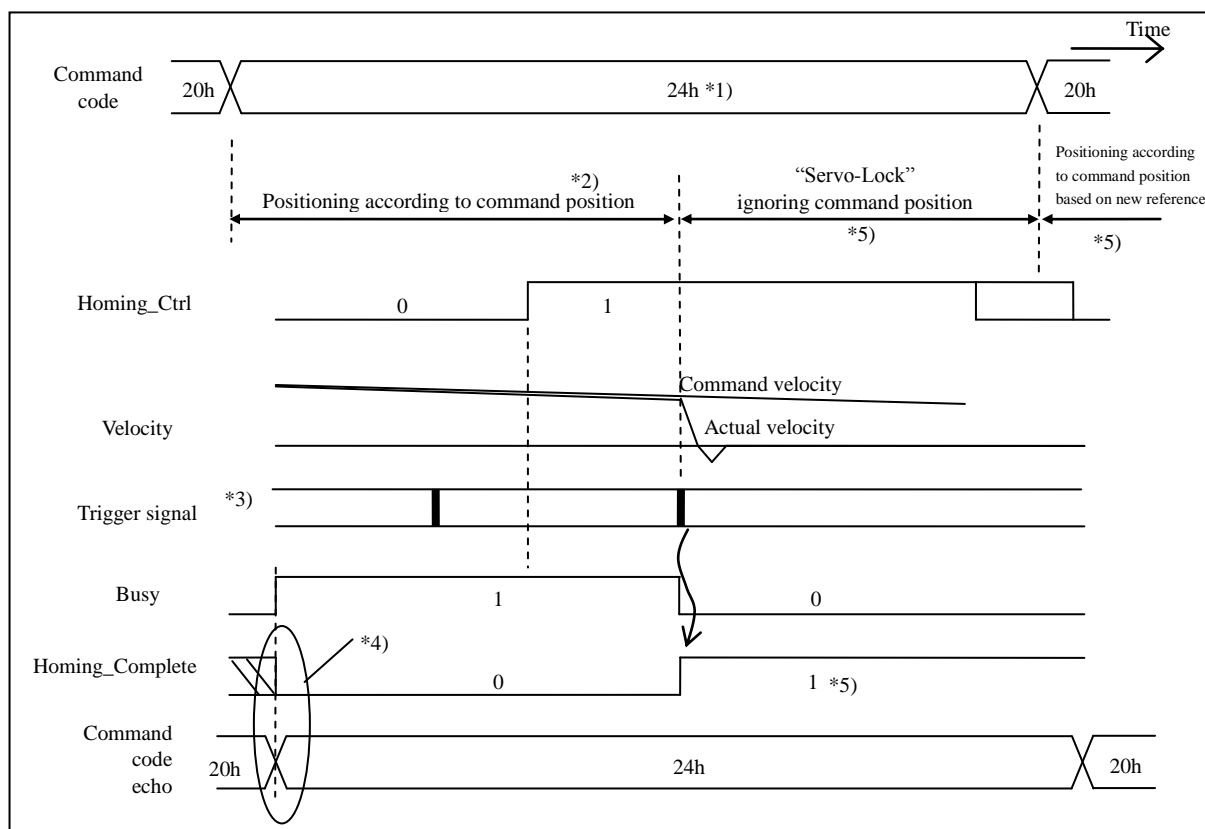

1) When command code (24h) is changed to normal command (20h), homing process can be paused even when Busy = 1. Even if Pr.7.23, bit 5 = 1 (start upon changing of command code and command argument), the normal command (20h) is required to pause the homing process. However, Err91.3 “RTEX command error protection 2” may occur if cancellation is executed immediately before completion of return to origin. In this case, check if cancellation of return to origin command is executed after stopping the motor.

* This is a specification for function extended version 5 and later versions.

*2) In the incremental mode (incremental external scale), internal command position and actual position are at 0 (home position) at power up. Until homing process completes (home position is set by trigger signal), apply the command position with reference to this 0 (home position).

*3) Using Type_code, select the logical rising or falling edge of the sensor or Z-phase as the trigger signal.

*4) Homing complete bit will be 0 when Homing command is accepted. Note that it is 0 at power-up until homing is completed. However, if the homing is started with Homing_Ctrl = 1 at communication cycle 0.5 ms or more and then the trigger signal is immediately detected, Homing_Complete will not be set to 0 but set to 1 after the completion of the process at the first response. The homing process is successfully completed when no command error is detected, echo back value is returned and Homing_Complete = 1.

*5) Homing complete bit will be 1 after homing is completed.

While the command code is holding 24h after Homing_Complete bit switched to 1, the servo driver will ignore the command position and will stop the motor (servo-lock) at detected home position.

Note that during feedforward the value remains valid. If this causes a problem, keep feedforward value at 0 during homing process.

During the process, be sure to set the command position to 0 (home position). When command code is started with normal command (20h) or another command, operation will be started by a command according to the new reference.

*6) • When the home position detection, the motor returns overshoot distance (Homing return).

At this time, in the case of high response setting to position command and high speed (mode of Two-degree-of-freedom control, etc), if run homing return, the sound may occur when the homing is completed.

• When the Pr7.22 bit6“Homing return speed limit function enabled” is set to “1”, homing return speed limit function is enabled.

If this function is enabled, homing return speed is limited by the Pr7.93“Home position return limit speed”. The effect of reducing the occurrence of sound is expected.

• Pr7.22 bit6 setting is activate after control power cycle, Pr7.93 setting is activate when reset command is enable or after control power cycle.

• If this function is enabled, there is a possibility that the time to homing completion extending.

• If this function is disabled, homing return speed is limited by the maximum motor speed that the driver have internally.

• When homing return speed exceeds the Pr5.13 “Over-speed level setup”, Err26.0“Over-speed protection” occurs. When homing return speed exceeds the Pr6.15 “2nd over-speed level setup”, Err26.1“2nd over-speed protection” occurs.

[Example of performing homing(Positive direction) with Index pulse]

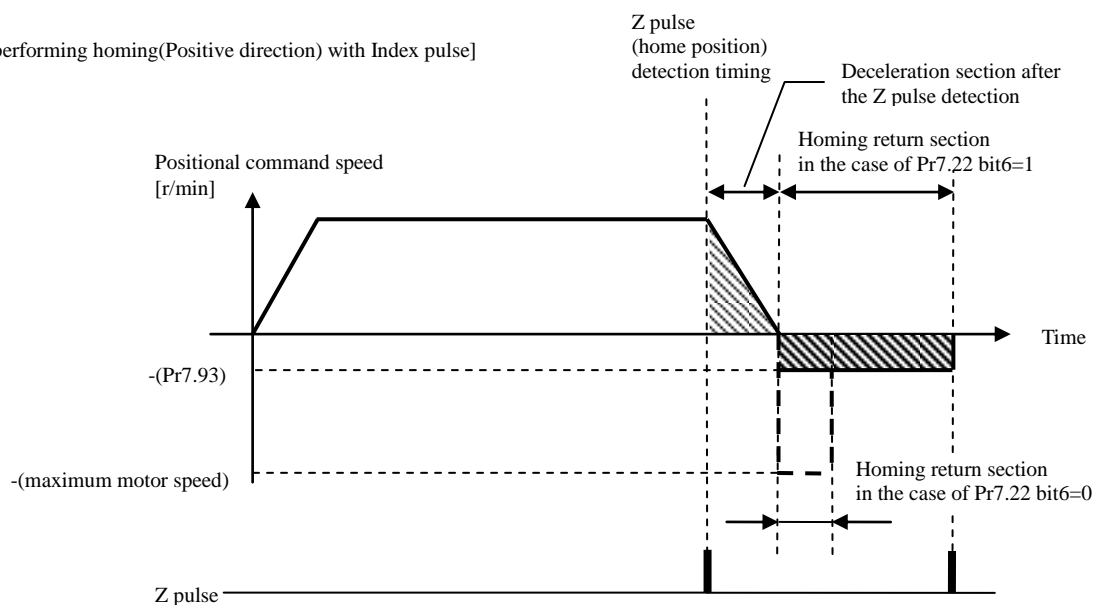

7-2-2 Sequence of actual position/command position setup

[Type_Code: 021h, 022h]

The figure below shows the sequence in which no trigger signal is used and at a position, actual position or command position is set to Setting_Data (Bytes 12–15).

During this operation, Homing_Ctrl bit is not used.

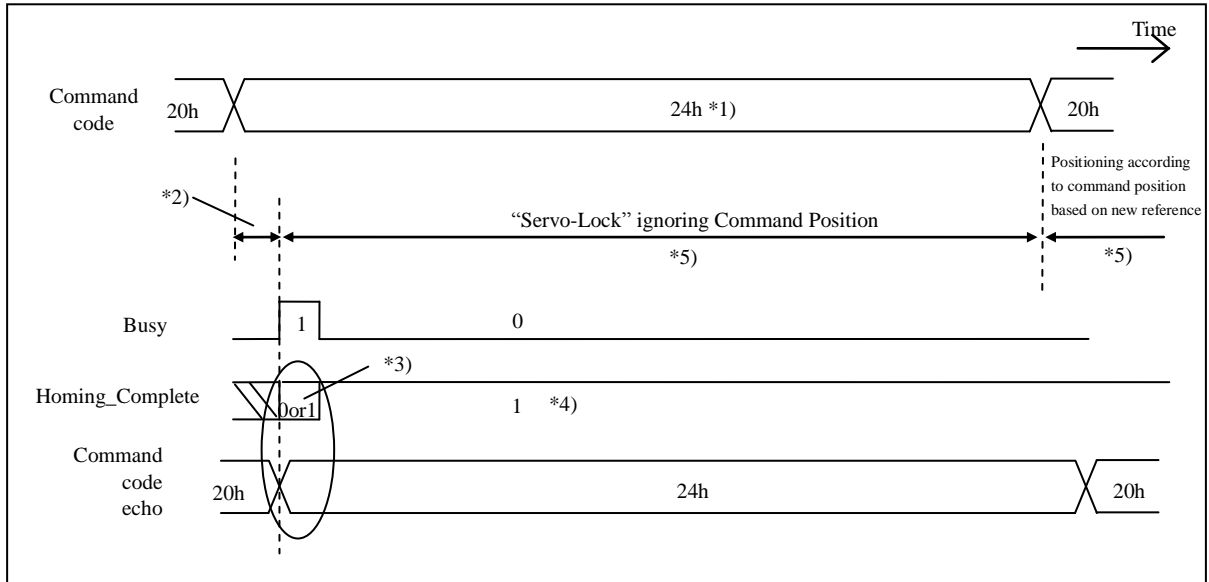

*1) When command code (24h) is changed to normal command (20h), homing process can be paused even when Busy = 1. Even if Pr.7.23, bit 5 = 1 (start upon changing of command code and command argument), the normal command (20h) is required to pause the homing process.

*2) Do not change command position (byte 4–7) to prevent a trouble.
(You must set the actual position/command position when the motor is not rotating.)

*3) Homing_Complete bit will be 0 when Homing command (actual position/command position set) is accepted. Note that it is 0 at power-up until homing is completed. However, if the communication cycle is 0.5 ms or more, Homing_Complete will not be set to 0 but set to 1 after the completion of process upon reception of the first response. The homing process is successfully completed when no command error is detected, echo back value is returned and Homing_Complete = 1.

*4) <Actual position setup>

The actual position is set to the value of Setting_Data (Bytes12–15) and the command position in the servo driver is also set to this value, the position deviation becomes 0.

Position information after operation
Actual position = command position = setting value (Setting_Data)
Position deviation = 0

<Command position setup>

The command position in the servo driver is set to the value of Setting_Data (Bytes12–15) of the command, and the actual position is set to the command position after setup minus position deviation value. The deviation is held.

Position information after operation
Internal command position = setting value (Setting_Data)
Actual position = internal command position (value after setup as shown above) – position deviation

Homing complete bit will be 1 after homing (actual position/command position setup) is completed.

- *5) At the time Homing_Complete bit is set to 1, the servo driver will ignore the command position and will stop the motor (servo-lock) at detected home position while command code is held to 24h.
Note that during feedforward the value remains valid. If this causes a problem, keep feedforward value at 0 during homing process.

When setting actual position, during this period, be sure to change the command position in the command to the actual position set. At the time the command code starts the normal command (20h) or another command, the driver will operate according to the command based on the new reference.

7-2-3 Example of cyclic homing operation

Example	Reference of homing	Method
1	Combination of sensor signal (HOME) and Z-phase of the encoder	Control the motor velocity with observing the sensor signal level, and operate Homing_Ctrl bit.
2	Sensor signal (EXT1)	
3	Z-phase of the encoder	Operate Homing_Ctrl bit
4	Mechanical stopper	Set up a smaller torque limit in advance, and execute "actual position set" when torque limited bit becomes 1 for a given length of time.

Note 1: When performing return-to-home by specifying the drive inhibit input (NOT/POT) as the reference home position, be sure to set Pr5.04 "Over-travel inhibit input setup" to 1 to disable the over-travel inhibit input. Otherwise, Err38.2 "Drive inhibit input protection 3" will occur.

Note that even if the inhibit input is disabled, the driver receives the signal and can use it as home reference signal.

Note 2: When performing home offset, do not use the actual position set but use the command position set. The actual position set may produce a deviation equal to the position deviation.

7-2-3-1 Example of cyclic homing operation 1

Below shows an example of return-to-home operation in the cyclic position control (CP) mode using the combination of sensor signal (HOME) and Z-phase of the encoder. In this example, the first encoder Z-phase after passing the sensing area of HOME sensor (position where one revolution data is zero) is the home.

- 1) Set Type_Code to Z-phase (011h) of the encoder and set Homing_Ctrl bit to 0, and then change normal command (20h) to homing command (24h).
Hold homing command (24h) until homing process completes.
- 2) Execute the positioning to rotate the motor at 1st velocity according to command position, which is based on the position at power-up.
- 3) Slow down the command velocity (2nd velocity) when the rising edge of HOME is detected with HOME bit of response.
- 4) Set Homing_Ctrl bit to 1 when the falling edge of HOME is detected.
- 5) When the servo driver detects Z-phase of the encoder, it will set Homing_Complete bit to 1, ignore command position and stop the motor (servo-lock) at home position (single turn data is zero).
Note that during feedforward the value remains valid. If this causes a problem, keep feedforward value at 0 during homing process.
- 6) After confirming that Homing_Complete bit has become 1, set Homing_Ctrl bit to 0, and then set 0 (home position) to command position.
- 7) Change the command code to the normal command (20h).
Then, positioning will start according to the new reference. Therefore, be sure to perform step 6) before changing the command code to the normal command.

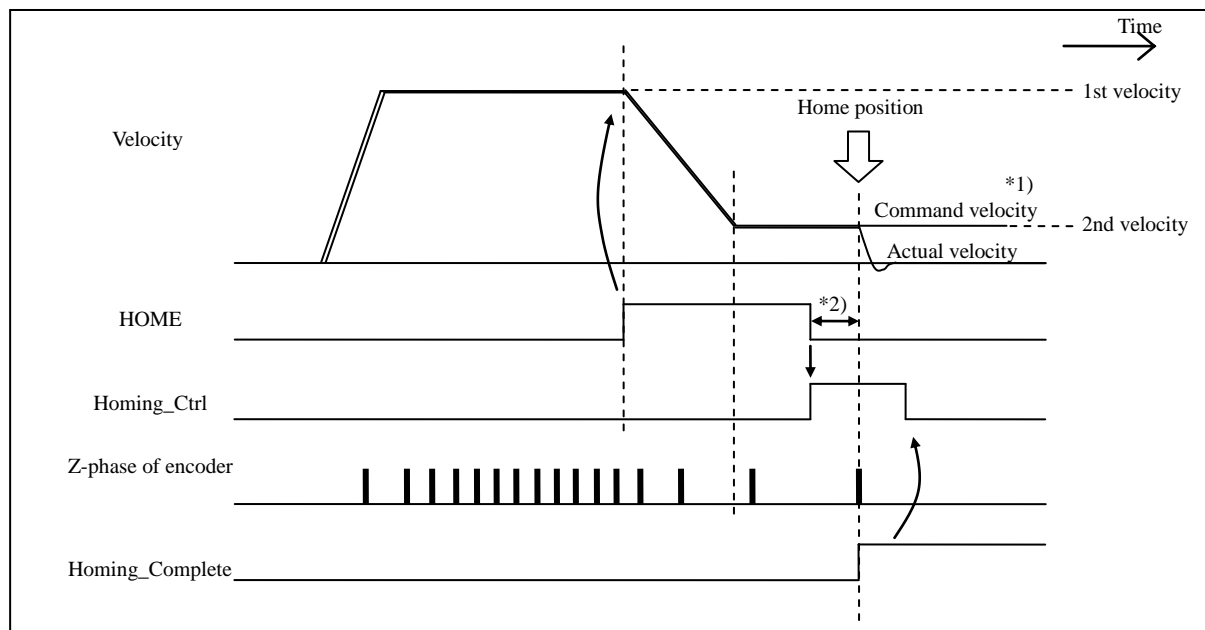

- *1) Command velocity is differences of command position for the command update cycle. (It is internal operation value of the servo driver.)
- *2) If the fall edge position of the HOME signal is close to the Z phase of the encoder, a turn's worth of misalignment may occur (due to the delayed detection of the HOME signal, etc.). Install the motor in a position separate by 180° in rotor mechanical angle, wherever possible.

(* Similarly, there is a possibility of position shift by not being able to acquire Z phase.)

The Z phase of the encoder and external scale can be checked with the following method.

semi-closed control

Method 1: Set parameter, Pr.7.00, "LED display" to 1 to display the mechanical angle on 7-segment LED, and check the zero position of the encoder where the value is 0.

Method 2: Read out the mechanical angle by monitor command, and check the zero position of the encoder where response value is 0.

ful-closed control

- serial communication typ use of incremental external scale

Method : Set the parameter Pr7.00(Display on LED) to 7.

When Z phase counter is displayed, the display where this signal changed.

- AB phase output type use of incremental external scale

Method : Check the original signal of Z phase, and the position where the signal changed.

7-2-3-2 Example of cyclic homing operation 2

Below shows an example which defines the logical rising edge of EXT1 sensor in the cyclic position control (CP) mode as the home.

- 1) Set Type_Code to logical rising edge of EXT1 sensor (018h) and set Homing_Ctrl bit to 0, and change normal command (20h) to return-to-home command (24h). Hold the return-to-home command (24h) until the return-to-home operation completes.
- 2) Execute the positioning (at 1st velocity) according to command position, which is based on the position at power-up.
- 3) When the logical falling edge of EXT1 sensor is detected (check EXT1 bit of the response), stop positioning and set Homing_Ctrl bit to 1. Then, reverse the rotation (2nd speed).
- 4) When the servo driver detects the logical rising edge of EXT1 sensor, set Homing_Complete bit to 1 and execute servo-lock at home position by ignoring command position.
Note that during feedforward the value remains valid. If this causes a problem, keep feedforward value at 0 during homing process.
- 5) After confirming that Homing_Complete bit has become 1, set Homing_Ctrl bit to 0, and then set 0 (home position) to command position.
- 6) Change the command code to the normal command (20h).
Then, positioning will start according to the new reference. Therefore, be sure to perform step 5) before changing the command code back to the normal command.

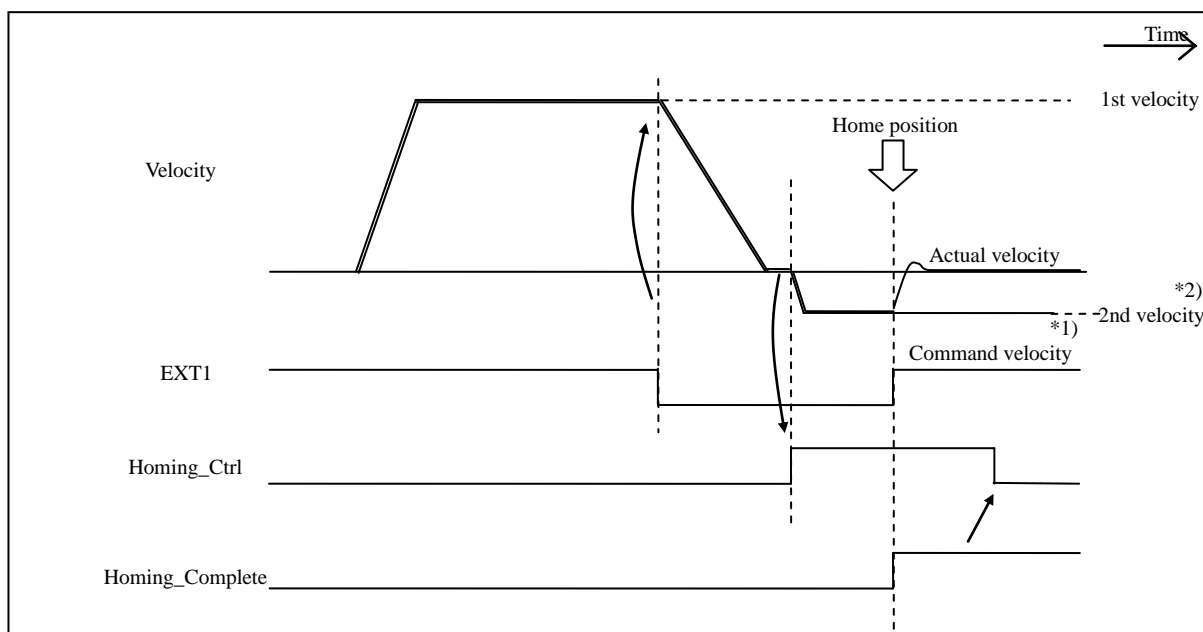

*1) Command velocity is the differences of command position for the command update cycle. (It is internal operation value of the servo driver.)

*2) Set up the 2nd Velocity as slow as possible.

Noise filtering process in the servo driver is executed when capturing sensor signals. This process causes the detection delay. To minimize this delay, correction process is installed which will degrade the home position detection precision if 2nd speed is set too high.

If you need higher accuracy, use the method of using the Z-phase of the encoder, and refer to “Example of cyclic homing operation 1” on the previous page.

When the trigger position is detected at a higher speed, especially with excessively low electronic gear ratio, e.g. 1/1000, wraparound of the detection position will occur upon reverse conversion to command unit, causing incorrect detection of the latch position. Latch trigger signal should be detected at the lowest possible speed.

7-2-3-3 Example of cyclic homing operation 3

Below shows an example of return-to-home operation in the cyclic position control (CP) mode using the Z-phase (zero position of single turn data) as the home.

- 1) Set Type_Code to Z phase (011h), set Homing_Ctrl bit to 1, and then change from normal command (20h) to return-to-home command (24h).
Hold the return-to-home command until the homing process completes.
- 2) Execute the positioning according to command position, which is based on the position at power-up.
- 3) When the servo driver detects Z-phase of the encoder, it will ignore command position and stop the motor (servo-lock) at detected home position (Z-phase). Then it will set Homing_Complete bit to 1.
Note that during feedforward the value remains valid. If this causes a problem, keep feedforward value at 0 during homing process.
- 4) After confirming that Homing_Complete bit has become 1, set Homing_Ctrl bit to 0, and then set 0 (home position) to command position.
- 5) Change the command code back to normal command (20h).
Then, positioning will start according to the new reference. Therefore, be sure to perform step 4) before changing the command code back to the normal command.

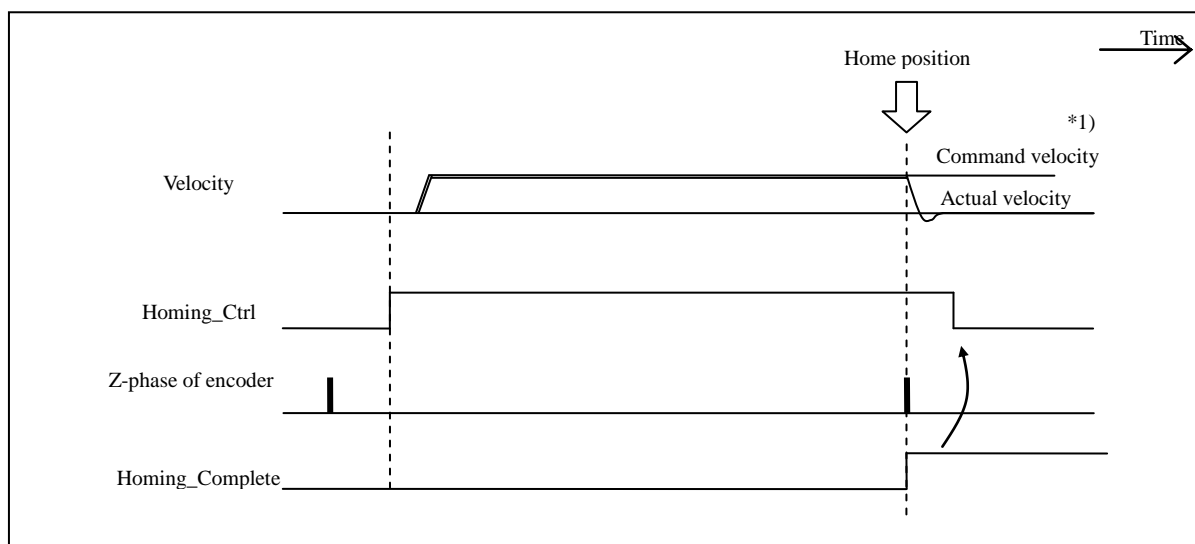

- *1) Command velocity is the differences of command position for the command update cycle. (It is internal operation value of the servo driver.)

7-2-3-4 Example of cyclic homing operation 4

Below shows an example of return-to-home operation in the cyclic position control (CP) mode using the mechanical stopper.

- 1) Lower the torque limit value with using parameter command (26h) or TL SW bit of command.
Note: For setting the torque limit value, see section 4-2-3-3.
- 2) Execute the positioning according to command position, which is based on the position at power-up. At this time, lower Command Velocity for safety.
- 3) Actual velocity will be 0 when the slider hit the stopper, and the status will show the torque limited (torque limited bit will be 1).
- 4) After verifying that the torque limited status continued for specified period (t_1), switch the command from normal (20h) to return-to-home command (24h). Set Type_Code to actual position set (021h) and setting position (Byte 12–15) to 0 (or desired value). Do not change the command position.
- 5) When the process of actual position set has completed in the servo driver, the driver will ignore the value of command position and stop the motor (servo-lock) at the setup position. Then it will set homing complete bit to 1.
Note that during feedforward the value remains valid. If this causes a problem, keep feedforward value at 0 during homing process.
- 6) After confirming that homing complete bit has become 1, then set the command position to the set actual position.
- 7) Change the command code back to normal command (20h).
Then, positioning will start according to the new reference. Therefore, be sure to perform step 6) before changing the command code back to the normal command.
- 8) Bring the torque limit value to the previous value.

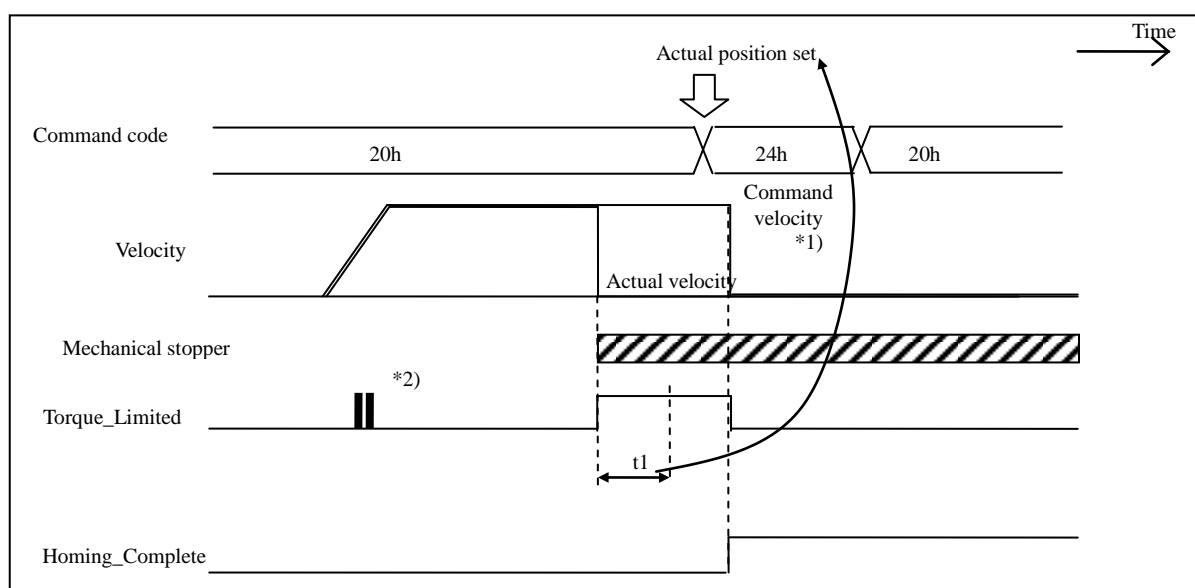

- *1) Command velocity is the differences of command position for the command update cycle. (It is internal operation value of the servo driver.)
- *2) Torque limited bit may be 1 even if the slider does not hit the stopper since the torque limit is lowered. Therefore, adjust t_1 to avoid mis-detecting.
Note that position deviation error (Err. 24.0) might occur when t_1 is too large.

7-2-4 Initialization of the absolute encoder

Homing operation is not necessary with the absolute encoder at the position control mode (except when using the absolute encoder as the incremental mode). However, it is necessary to clear “Multi-turn data” at the first start up of the machine after installing the battery. (except for single-turn absolute mode)

7-2-4-1 Absolute data

There are 2 types of data which are read out from the absolute encoder (23 bits/r), “Single-turn data” which shows the position of motor’s rotation within a single turn, and “Multi-turn data” which counts each single turn. This Multi-turn data will be backed up by a battery since this is an electrical counter.

Both data have a polarity to increase in the direction of CCW.

You can select whether Err41.0, “Absolute encoder counter overflow” will be generated or not when Multi-turn data has overflowed, with the parameter, Pr0.15 “Absolute encoder set up”.

	Back up at power off	Data width	+/- Sign	Data range
Single-turn data	Not necessary	23 bit	Unsigned	0–8388607
Multi-turn data	Backed up by battery	16 bit	Signed	0–65535(Max) *1)

*1) In case of infinitely rotatable absolute mode, the upper limit value can be set by Pr6.88 “Absolure encoder multi-turn data upper-limit value”.

During normal absolute mode, the upper limit value becomes up to 65535.

For details of the infinitely rotatable absolute encoder mode, see chapter 6-7 of technical document Basic function Specification.

This servo amplifier executes initialization of the actual position based on the equations below at the following timings.

When the power is turned on or when the absolute multi-turn is cleared via PANATERM or RTEX

When the PANATERM operation (trial run, frequency property analysis, Z phase search, or fit gain) is completed

When PANATERM pin assignment is made or when the attribute C parameter validation mode is set via RTEX

A 23-bit absolute encoder uses 23 bits for single-turn data and 16 bits for multi-turn data, which amounts to 39 bits for compound real positions, but a real position value returned to the host device is a 32-bit value. Therefore, the valid bit count for multi-turn data varies depending on the value of electric gear reverse conversion. *2) If the real position value calculated from the single-turn and multi-turn data exceeds 32 bits, Err29.1 “counter overflow protection 1” occurs.

Parameter Pr.0.00 (Rotational direction setup)	Actual_position *3)
When set to 1 (CCW is positive direction)	$APOS = ((M \times 2^{23} + S) \times \text{electric gear reverse conversion value}) + OFS$
When set to 0 (CW is positive direction)	$APOS = -((M \times 2^{23} + S) \times \text{electric gear reverse conversion value}) + OFS$

*2) In versions corresponding to function extended edition 2 or earlier, the maximum effective bit length for multi-turn data is set to 7 bit.

*3) If the electronic gear ratio is 1:1, the effective bit length for multi-turn data is set to 9 bit.

If the electronic gear ratio is 2:1, the effective bit length for multi-turn data is set to 10 bit.

When you set the electric gear, make sure that APOS can be represented by a signed 32-bit value.

APOS: Actual_Position

M: Multi-turn_Data

S: Single-turn_Data

OFS: Pr7.13 “Absolute home position offset”

If you need the position information of an absolute encoder of 32 bits or over, you can calculate it by the formula below.

You can obtain single-turn data and multi-turn data by the RTEX monitoring command (□Ah).

Read out single-turn data and multi-turn data at the same time.

$$\text{Multi-turn data} \times 2^{23} + \text{single-turn data}$$

Function extended version 3 and later versions have extended effective bit length for multi-turn data, and can handle number of turns up to 65535 by setting Pr6.98 bit3 “Effective bit extension for multi-turn data” to 0.

	Pr6.98 bit3	Effective range for encoder data	Effective maximum number of turns						
Function extended version 2 and earlier	-	<table border="1"> <tr> <td>Single turn data 23bit</td> <td>Multi-turn data 9bit</td> <td>7bit</td> </tr> <tr> <td colspan="3" style="text-align: right;">Ignore</td> </tr> </table>	Single turn data 23bit	Multi-turn data 9bit	7bit	Ignore			-255 ~ 256 Turn *2)
Single turn data 23bit	Multi-turn data 9bit	7bit							
Ignore									
Function extended version 3 and later	1	<table border="1"> <tr> <td>Single turn data 23bit</td> <td>Multi-turn data 9bit</td> <td>7bit</td> </tr> <tr> <td colspan="3" style="text-align: right;">Ignore</td> </tr> </table>	Single turn data 23bit	Multi-turn data 9bit	7bit	Ignore			-255 ~ 256 Turn *2)
	Single turn data 23bit	Multi-turn data 9bit	7bit						
Ignore									
	0	<table border="1"> <tr> <td>Single turn data 23bit</td> <td>Multi-turn data 16bit</td> <td></td> </tr> </table>	Single turn data 23bit	Multi-turn data 16bit		-32768 ~ 32767 Turn *3 *4)			
Single turn data 23bit	Multi-turn data 16bit								

*2) It is indicated as a data without sign on display.

Example) Multi-turn data 1 is handled as 1, and 256 as -1.

*3) It is treated as unsigned data on display.

Example) Multi-turn data 1 is handled as 1. and 65535 as -1.

*4) The actual position value calculated from 1-turn data, multi-turn data and electronic gear back-up value needs to remain within 32bit width.

Since the shipment setup value for Pr6.98 bit3 is 0, use it by setting Pr6.98 bit3 to 1 if you wish to mask the upper 7bit of multi-turn data. The purposes to mask the upper 7bit of multi-turn data include axes turning infinitely in one direction with electronic gear ratio of 1. Please note that there are multiple actual positions.

Differences in actual position by the effective multi-turn bit number when electronic gear ratio is 1 are shown below.

[Function extended version 2 and earlier, or
Function extended version 3 and later,
and Pr6.98 bit3=1]

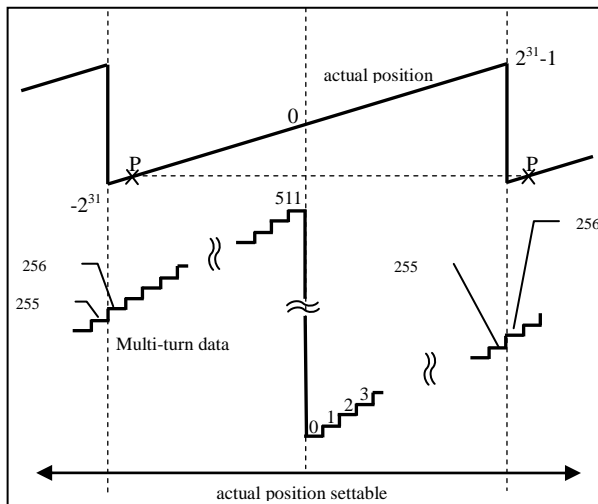

[Function extended version 3 and later,
and Pr6.98 bit3=0]

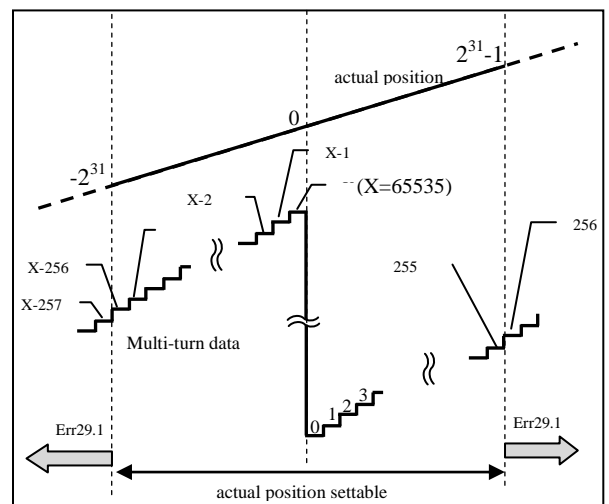

In addition, it can be calculated using the equation below if the position information on absolute encoder of 32bit or larger is required.

You can obtain single-turn data and multi-turn data by the RTEX monitoring command (\square Ah).

Read out single-turn data and multi-turn data at the same time.

$$\text{Position information on absolute encoder} = \text{Multi-turn data} \times 2^{23} + \text{single-turn data}$$

(1) Related parameters

The number of multi-turn data which is effective in actual position setup varies depending on the electronic gear ratio, Pr0.15 "Absolute encoder setting," Pr6.98 bit3 "Effective bit switching in multi-turn data." Please use it by setting up the following parameters to suit the purpose with reference to related parameter setup examples.

Class	No.	Attri- Bute	Title	Range	Unit	Function
0	08	C	Command pulse counts per one motor revolution	0~ 8388608	Pulse	Specifies the number of command pulses equivalent to one revolution of a motor. If this value is 0, Pn0.09 "Numerator of electronic gear ratio" and Pn0.10 "Denominator of electronic gear ratio" are valid. This setting is invalid under full-closed.
0	09	C	Numerator of electronic gear	0~ 1073741824	-	Set the numerator of electronic gear ratio *1) Valid when Pn0.08 "Number of command pulses per revolution of motor" is 0. When the setup value is 0, the numerator is replaced by the encoder resolution. Electronic gear ratio shall be 1:1 when the set value is 0 under full-closed.
0	10	C	Denominator of electronic gear	1~ 1073741824	-	Set the denominator of electronic gear ratio *1) Valid when Pn0.08 "Number of command pulses per revolution of motor" is 0.
0	15	C	Absolute encoder setup	0~4	-	Select the use method of the absolute encoder. *2) 0: Use as an absolute system (absolute mode). 1: Use as an incremental system (incremental mode). 2: Use as an absolute system (absolute mode), however ignore the multi-turn counter over. 3: Use as an absolute system, however not use the multi-turn counter (single-turn absolute mode). 4: Used as an absolute system (absolute mode), however any upper limit value can be set for the multi-turn counter, and ignore the multi-turn counter over. (continuous rotating absolute mode)
6	88	C	Absolute encoder multi-turn data upper-limit value	0~65534	-	Set the upper limit value for absolute multi-turn data when unlimited turn absolute mode (Pr0.15 to 4) is set. When the multi-turn data is more than the value set for this parameter, the multi-turn data changes to 0. When the multi-turn data falls below 0, multi-turn data will change to the set value. When absolute mode (Pr0.15 to 0 or 2) is set, the upper limit value for multi-turn data is set to 65535 regardless of the setting value. When incremental mode (Pr0.15 to 1) or one-turn absolute mode (Pr0.15 to 3) is set, this setting value will be invalid.
6	98	R	Function expansion setup 4	-2147483648 - 2147483647	-	bit3 : Effective bit switching in multi-turn data. 0 : Valid(-32768~32767 Turn) 1 : Invalid(-256~255 Turn)

*1) In the range from 1/1000 to 8000: out of this range will cause Err. 93.0 "Parameter setting error protection".

*2) It is handled as an incremental system (setting value = 1) in internal control under full-closed control.

7-2-4-2 Clearing multi-turn data

When clearing multi-turn data, zero position will be multi-turn transition point at CW side in the zone where cleared. In order to avoid the setting difference, execute the clearing operation at the position where single-turn data is 2^{22} (when 23bit/r), which is the farthest from the transition point of multi-turn data.

< Notes to avoid a trouble >

Execute this process (clear multi-turn data) in Servo-OFF (and fixing the moving parts by brake etc. if necessary) and confirming safety.

Keep Servo-OFF until data clearing completes. After that, turn off control power once without fail, and turn on the power again.

It is done to clear multi-turn data using the setup support software PANATERM (USB communication).

At that time, Err27.1, "Motion command error" will occur. However, this is not a problem because of a step for safety.

As another way, the following figure shows the clearing sequence using homing command.

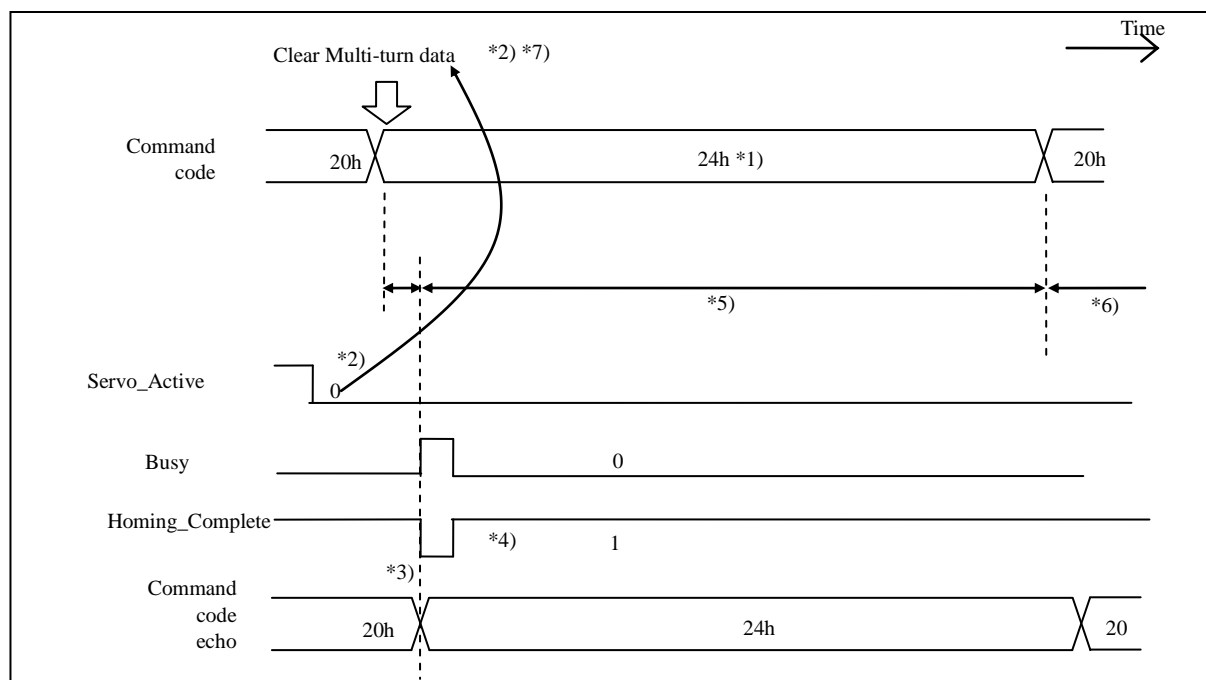

- *1) If command code (24h) is not held, homing process (clear multi-turn data) will be aborted. While the process is executed, hold command code and do not abort homing process.
- *2) Execute this process (clear multi-turn data) in Servo-OFF (and fixing the moving parts by brake etc. if necessary) and confirming safety to avoid a trouble.
- *3) When using as the absolute mode, homing complete bit is 1 after the reset, and it will be 0 when this command is accepted.
Multi-turn data in the servo driver will be cleared and actual position will be initialized.
- *4) After initialization of the actual position Homing_Complete bit is set to 1.
- *5) After Command is accepted, hold Command Code (24h) for 10 ms or longer without fail. Though internal data of the servo driver will be initialized soon, actually it takes longer time to initialize the encoder.
- *6) It is required to turn off and on the control power of the servo driver after clearing multi-turn data. Note that reset command cannot initialize the encoder
- *7) If multi-turn clearing of the absolute encoder has been executed when the single-turn absolute function is effective, command error (0051h) will be returned.

7-2-5 Sequence for latch mode with stop function

[Type_Code : Flh, Trigger signal : external input signal]

The figure below shows the sequence for latch mode with stop function using the rising logic edge for latch trigger signal with stop function (hereafter referred to as the trigger signal) as the external input signal, and uses the logical rising edge.

Unlike home position return, latch mode with stop function does not initialize the position information. In addition, it is not necessary to set Homing_Ctrl bit to 1 to start up the sequence.

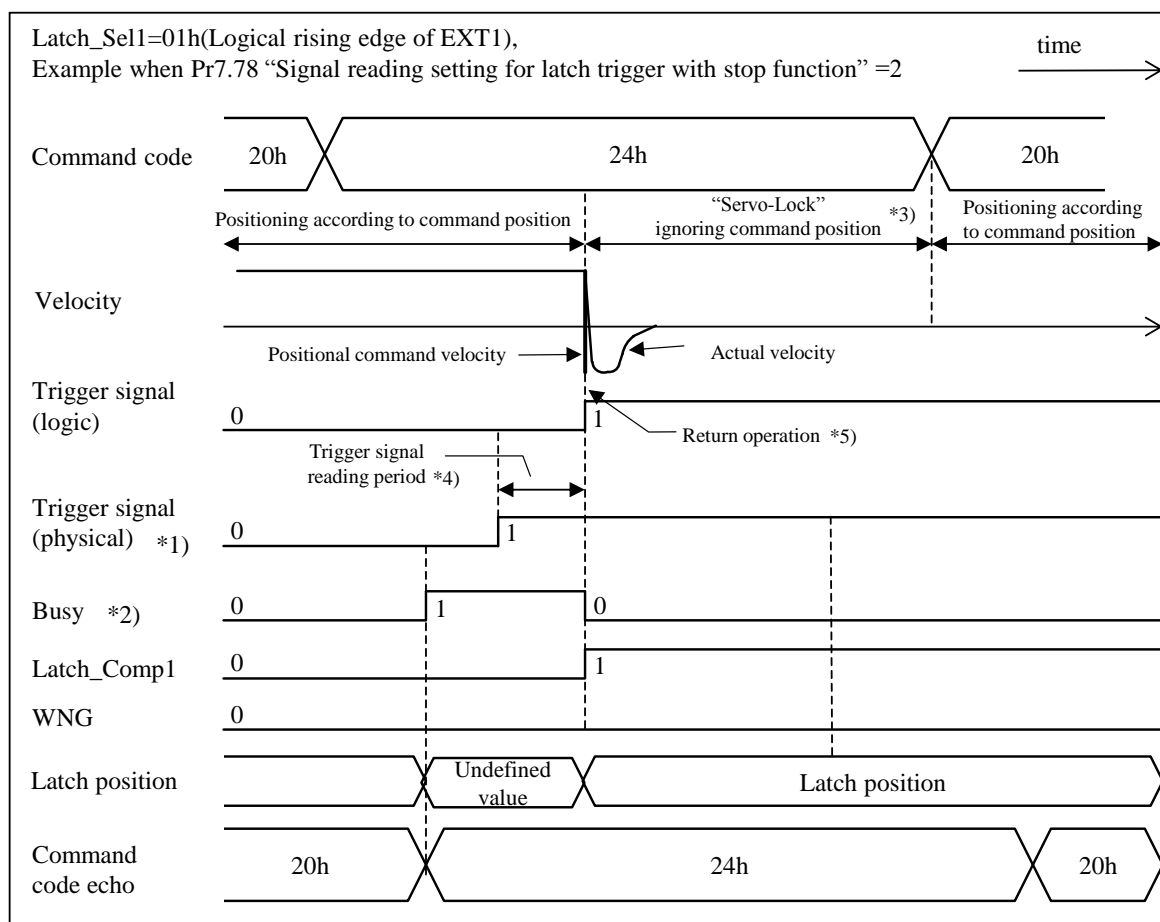

- *1) Logic for the trigger signal (a-contact/b-contact) depends on the amplifier parameter setting. Please use by setting up the parameters to be used corresponding to the trigger signal (Pr4.04 to Pr4.06) properly. In addition, the logic edge for the trigger signal (rising/falling) is selected in Latch_Sel1.
- *2) For latch mode with stop function, operation can be canceled by changing from homing command (24h) to a normal command (20h) even if Busy is "1." Even when Pr7.23 bit5=1 "startup by change in command code and command argument", the command must be changed to a normal command (20h) in order to cancel.
- *3) For latch mode with stop function, it stops (goes into servo lock) at the detected latch position while neglecting the command position from the host device when trigger signal input (logic) is detected, while the homing command (24h) is retained. However, please note that the value remains effective if feed forward is ON. If this may cause a problem, set the feed forward value for latch mode with stop function to 0. When doing so, be sure to also set up the command position to the latch position returned from the servo driver. If the command position is not set to the latch position at the point when the command code is changed to a normal command (20h), it may result in unintended operation or generation of Err27.4 "Command error protection".

- *4) The trigger signal reading period is the period between the input of the trigger signal (physical) until confirmation of the trigger signal (logic) and starting of position latch. This period varies depending on the setting value for Pr7.78 "Signal reading setting for latch trigger with stop function".
- *5) With latch mode with stop function, there will be a return operation to go back by the amount exceeding from the latch position when the trigger signal (logic) is confirmed.
- During the return operation period, the position command filter is cleared to minimize the amount of excess. If latch mode with stop function is executed in this case with high response setting to the position command and with a high velocity, including having two-degree-of-freedom control enabled, a noise may occur at completion.
 - The effect to reduce the noise generation can be expected as the return operation velocity is restricted to the setting value for Pr7.93 "Home position return limit speed", by setting Pr7.22 bit6 "Return to origin operation velocity restriction function activation" to "1" and enabling the home position return operation speed limit function.
 - Changes in settings for Pr7.22 bit6 are reflected by restarting the control power supply for the servo driver, and the changes in settings for Pr7.93 by execution of reset command or restarting the control power supply for the servo driver.
 - When return operation speed restriction function in return to origin is enabled, the period until the completion of latch mode with stop function may be extended.
 - When return operation speed restriction function in return to origin is disabled, the return operation speed will be restricted to the motor maximum speed retained internally by the amplifier.
 - Err26.0 "Over-speed protection" will occur if the return operation velocity exceeds the set value in Pr5.13 "Over-speed level setup," and Err26.1 "2nd over-speed protection" occurs if it exceeds the set value in Pr6.15 "2nd over-speed level setup."
 - Err91.3 "RTEX command error protection 2" may occur if operation is canceled during return operation.

【Example of executing latch mode with stop function (positive direction) using EXT1】

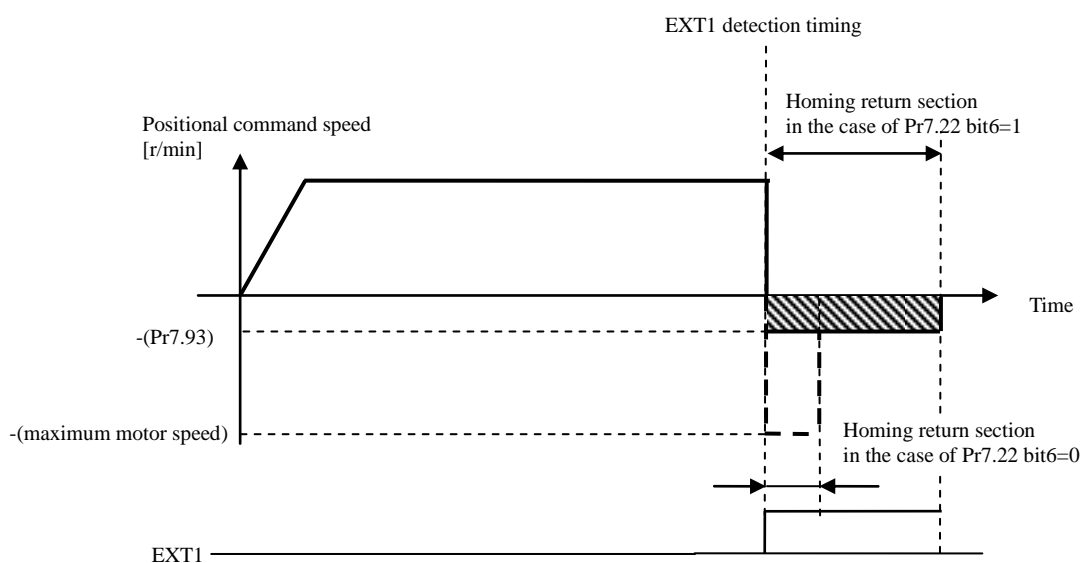

[Type_Code : F1h, Trigger signal : external output signal]

The figure below shows the sequence for latch mode with stop function which sets the latch trigger signal with stop function (hereafter referred to as trigger signal) as the external input signal, and uses the logical rising edge. Latch mode with stop function does not initialize the position information unlike return to origin. There is also no need to set the Homing_Ctrl bit to 1 to start up the sequence.

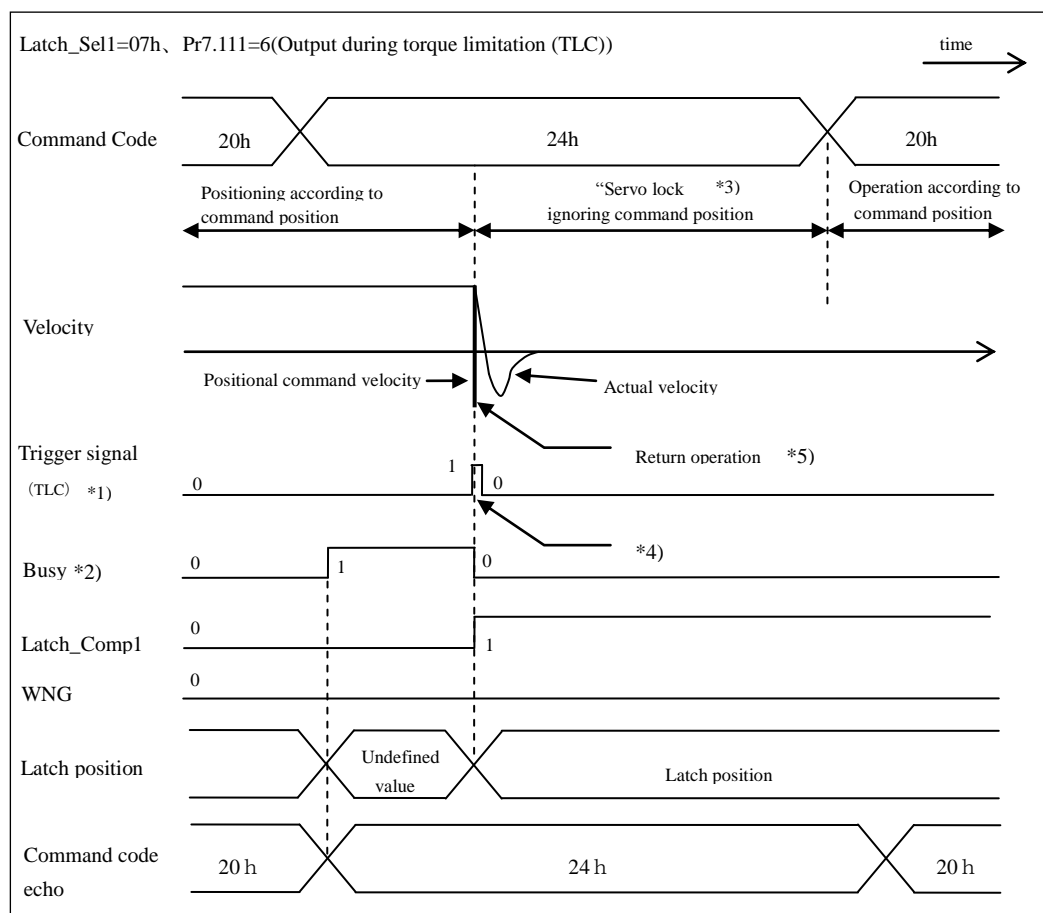

*1)When setting the trigger signal as amplifier output signal, please set up Pr7.111 "Trigger signal assignment setup for latch mode with stop function" properly.

In addition, the logical edge (rising/falling) for trigger signal is selected by Latch_Sel1.

*2)The operation can be canceled under latch mode with stop function by changing from return to origin command (24h) to normal command (20h) even when Busy is "1."

To cancel even when Pr7.23 bit5=1 (startup by change in command code and command argument), it needs to be changed to normal command (20h).

*3)In latch mode with stop function, the position commanded by the host device is neglected and it stops at the detected latch position (servo lock) once the trigger signal (logical) is detected while the return to origin command (24h) is retained.

However, please note that the value remains effective while feed forward is on. If this is considered a problem, set the feed forward value to 0 under latch mode with stop function.

Be sure to set up the commanded position for the command at the latch position returned from the amplifier.

If the commanded position is not set to the latch position at the point when command code is changed to normal command (20h), unintended operations or Err27.4 (Command error protection) may occur.

- *4) When the trigger signal is set as the amplifier output signal, trigger signal is detected when the amplifier satisfies the conditions for output signal, with no effect from the setting value in Pr7.78 (Trigger signal reading setup for latch with stop function).
- *5) In latch mode with stop function, a return operation to return by the amount of travel that was excessive compared to the latch position is executed when trigger signal (logical) is confirmed.
- Position command filter is cleared during the return operation in order to minimize the amount of over-travel. If latch mode with stop function is executed at a high speed with a setting in which response to position command is high, including two-degrees-of-freedom control being effective, noise may be generated at completion.
 - It is possible to restrict the return operation speed at the setting value in Pr7.93 “Return to origin return operation limit speed” and expect an effect to reduce noise generation by setting Pr7.22 bit6 “Enable return to origin return operation speed limit” to “1” to enable the return to origin return operation speed limit function.
 - The setting change in Pr7.22 bit6 is reflected by restarting the amplifier control power supply, and the setting change in Pr7.93 by reset command execution or restarting of amplifier control power supply.
 - Enabling the return to origin return operation speed limit function may result in extension of the period until the completion of latch mode with stop function.
 - When the return to origin return operation speed limit function is disabled, the return operation speed is restricted to the maximum motor speed retained internally by the amplifier.
 - Err26.0 “Over-speed protection” occurs if the return operation speed exceeds Pr5.13 “Over-speed level setup,” and Err26.1 “2nd over-speed protection” occurs if it exceeds the setting value in Pr6.15 “2nd over-speed level setup.”
 - When operation is canceled during return operation, Err91.3 (RTEX command error protection 2) may occur. In this case, check if latch command with stop function was executed after stopping the motor.

[Example of executing latch mode with stop function (positive direction) using TLC]

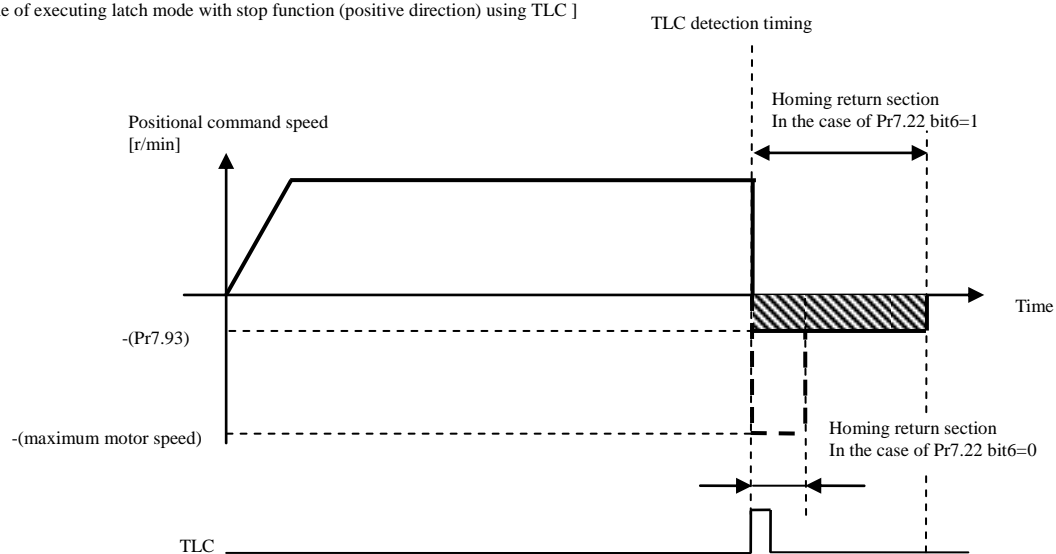

7-2-5-1 Example of latch mode with stop function

Below shows an example of latch mode with stop function operation in the cyclic position control (CP) mode using the latch signal with stop function (EXT1).

- 1) Set Type_Code to start position latch with stop function (F1h), set command Byte10 (Latch_Sel1) to logical rising edge of EXT1 (01h), command Byte11 (Monitor_Sel) to LPOS1 (09h), and then change normal command (20h) to homing command (24h).
Hold homing command (24h) until latch mode with stop function is completes.
- 2) On the host controller, check that Command_Code _Echo is 24h, the Type_Code_Echo is F1h, no command error has occurred, and latch mode with stop function has started. If command error has occurred, start proper counter measure according to the error code.
- 3) Execute the positioning according to command position, which is based on the position at power-up.
- 4) When the servo driver detects logical rising edge of EXT1, positioning is made to the latch position ignoring the command position and stop the motor (servo-lock).
Note that during feedforward the value remains valid. If this causes a problem, keep feedforward value at 0 during homing process.
- 5) On the host controller, after confirming that Latch_Comp bit has become 1, set the command position to the latch position.
- 6) Change the command code to the normal command (20h).
Then, positioning will start according to the new reference. Therefore, be sure to perform step 5) before changing the command code to the normal command.

7-3 Cyclic velocity control (CV) operation

Use this operation when performing velocity control by setting command velocity to CSPD.

Servo driver's control mode is velocity control without position loop. Input the velocity command directly to the velocity loop.

When this command is received in case of two degree-of-freedom (synchronous) mode under full closed control, Err91.1 "RTEX command error protection" and command error (002Eh) will occur.

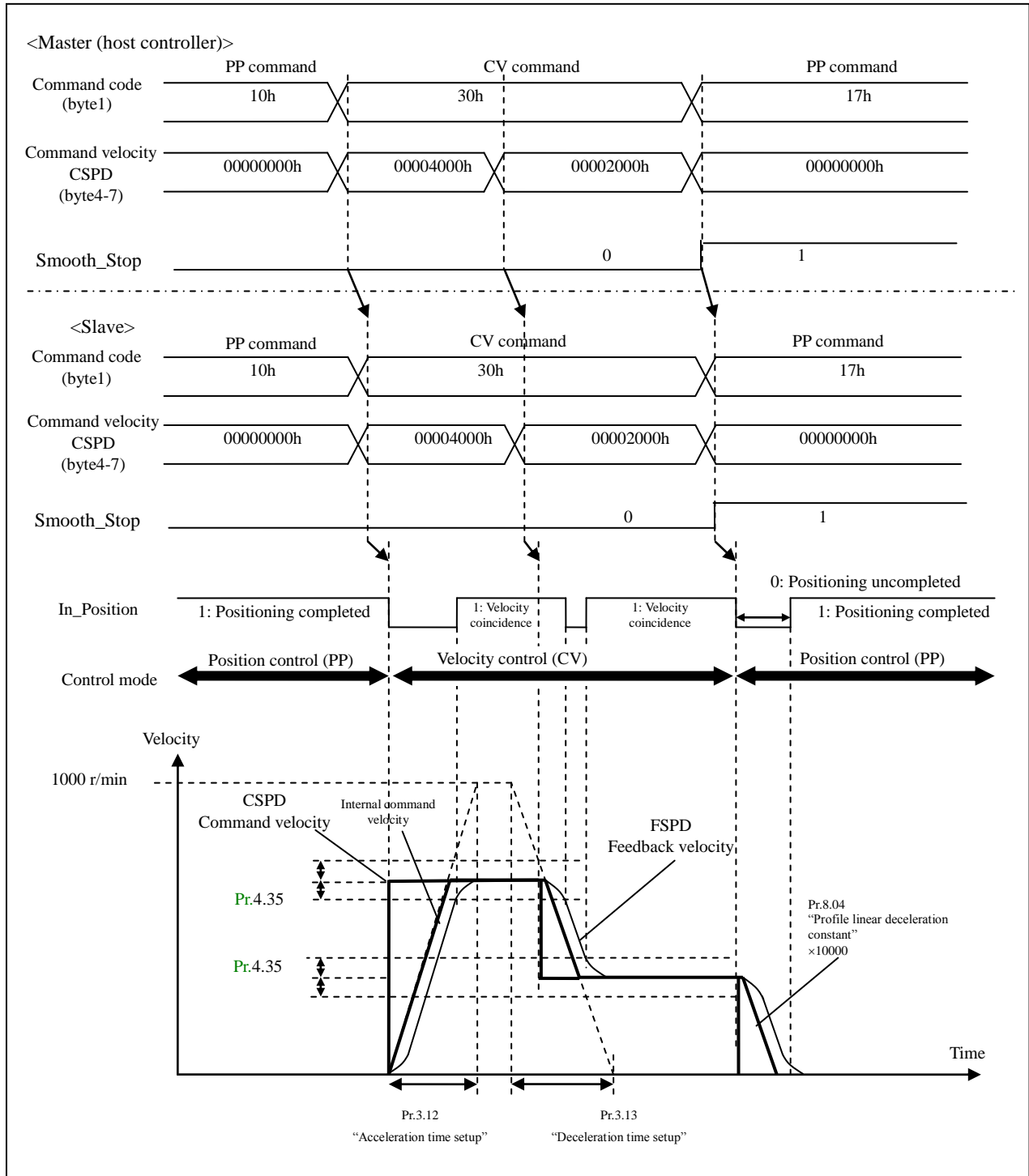

- 1) When using acceleration/deceleration for velocity command on the servo driver, set acceleration/deceleration through Pr3.12 “Acceleration time setup”, Pr3.13 “Deceleration time setup” and Pr3.14 “Sigmoid acceleration/ deceleration time setup” beforehand.

When the position loop is configured on the host controller, set Pr3.12, Pr3.13 and Pr.3.14 to 0.

When stop the operation with profile position control, set deceleration to Pr8.04 “Profile linear deceleration constant” before starting operation.

- 2) On the host controller set command code to CV control normal command (30h) and set command velocity (CSPD).
- 3) On the servo driver, change control mode from position control to velocity control as the command code 10h changes to 30h, to accelerate (start operation) to command velocity (CSPD).
- 4) On the host controller, check that command code echo is 30h, no command error has occurred, and velocity control has started. If command error has occurred, start proper counter measure according to the error code.
- 5) When command velocity (CSPD) is changed during operation, the servo driver updates the velocity upon receiving the command.

If the new command velocity (CSPD) is higher than the current command velocity, acceleration is made based on Pr3.12, and if the new command velocity is lower than the current velocity, deceleration is made based on Pr3.13.

- 6) To start stopping sequence, set the command velocity (CSPD) to 0. To use profile position control during stop sequence, set command code to 17h and Hard_Stop to 1 for immediate stop, or set Smooth_Stop or Pause to 1 to start deceleration according to Pr8.04 setting.
- 7) When profile position control is used for stopping sequence: after completion of output of movement command, status In_Progress becomes 0 (transfer complete), and absolute value of position deviation becomes below Pr4.31 “Positioning complete range”, servo driver sets In_Position to 1 and informs the host controller that positioning has been completed.

7-4 Cyclic torque control (CT) operation

Use this operation when setting command torque to CTRQ and performing torque control operation.
The servo driver operates in torque control mode based on velocity loop.

When this command is received in case of two degree-of-freedom (synchronous) mode under full closed control, Err91.1 “RTEX command error protection” and command error (002Eh) will occur.

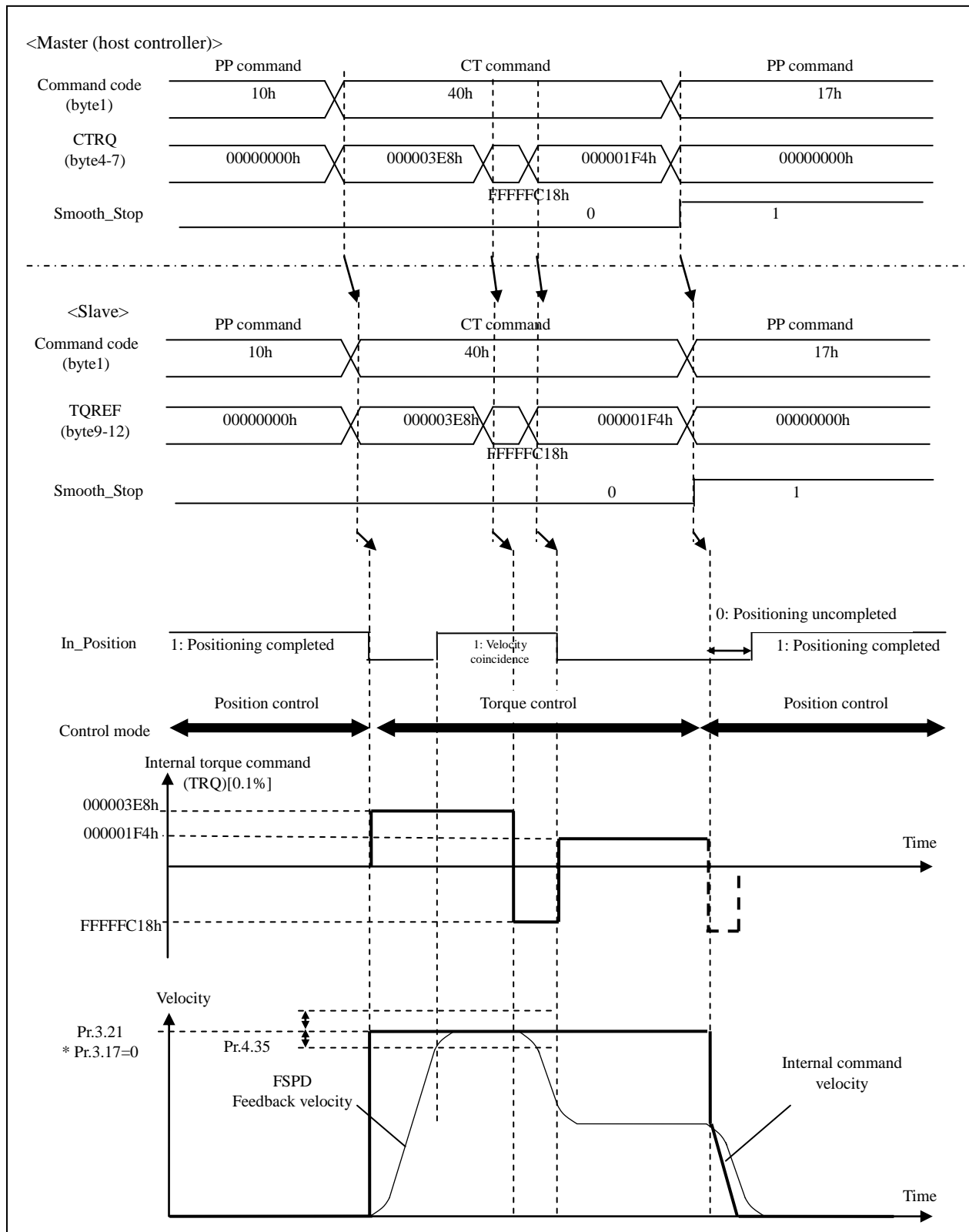

- 1) When stopping by using profile position control, set the deceleration by Pr8.04 “Profile linear deceleration constant” beforehand.
- 2) The host controller sets command code to normal command (40h) of CT control and sets command torque (CTRQ).
- 3) The servo driver changes the control mode from position to torque as the command code is changed from 10h to 40h, starting acceleration (starting operation) according to command torque (CTRQ).
- 4) On the host controller check that command echo is 40h and no command error has occurred and torque control has started. If a command error has occurred, take appropriate countermeasure according to the error code.
- 5) Upon receiving new command torque (CTRQ) during operation, servo driver updates the torque.
- 6) To trigger stop sequence, set command torque (CTRQ) to 0. To stop with profile position control, set command code to 17; to stop immediately, set Hard_Stop to 1; to decelerate according to the setting of Pr.8.04, set Smooth_Stop or Pause to 1.
- 7) When stopping under profile position control, the servo driver sets In_Position to 1 as status In_Progress is set to 0 (transfer complete) and absolute position deviation is below the value specified by Pr4.31 “Positioning complete range”, and informs the host controller that the positioning operation has completed.

■ Precautions

- While the velocity limit is active, the command torque (CTRQ) from the host controller is not directly applied to the motor. As the motor velocity is controlled to the velocity limit value, the result is reflected on the torque command to the motor. For velocity control function, refer to 4-2-3-4.
- While the torque control is active, torque limit switching function is disabled and only Pr0.13 “1st torque limit” is valid.
- When absolute value of command torque (CTRQ) exceeds the value of Pr0.13 “1st torque limit”, Pr0.13 is given priority.
- It may not stop even when the command torque (CTRQ) is set to 0, if there is a disturbance on the vertical axis and so forth.

7-5 Profile position control (PP) operation

7-5-1 Profile position control (PP) related parameter

Class	No.	Attribute	Title	Setup range	Unit	Description
8	01	B	Profile linear acceleration constant	1-429496	10000 command unit/s ²	Set up the acceleration under profile position control (PP) and retreat operation. Be sure to set before starting operation.
8	04	B	Profile linear deceleration constant	1-429496	10000 command unit/s ²	Set up the deceleration under profile position control (PP) and retreat operation. Be sure to set before starting operation.
8	10	B	Amount of travel after profile position latch detection	-1073741823 - 1073741823	Command unit	Set the movement distance after detection of latch trigger signal input position, during profile position latch positioning.
8	12	B	Profile return to home position mode setup	0-1	-	Select the polarity of latch trigger signal to be detected during profile homing operation. 0: Positive direction 1: Negative direction • For profile homing 2 or 4, select 0 setting. Setting to 1 also causes homing operation in positive direction.
8	13	B	Profile home position return velocity 1	0- 2147483647	Command unit/s or r/min	Set the velocity for high velocity operation during profile homing. Set the unit according to Pr.7.25 "RTEX speed unit setup". Maximum value is limited by the internal process to the motor highest velocity. • When speed setting is in r/min, it is converted to command unit/s through internal computation and the equivalent value is limited within the range as shown below: 00000001h to 7FFFFFFFh (1 to 2147483647) When setting value is 0, it is changed to 1 by internal process and used for control.
8	14	B	Profile home position return velocity 2	0- 2147483647	Command unit/s or r/min	Set the velocity for low velocity operation during profile homing. To minimize detection error, set the velocity to the lowest possible value. Set the unit according to Pr.7.25 "RTEX speed unit setup". Maximum value is limited by the internal process to the motor highest velocity. • When speed setting is in r/min, it is converted to command unit/s through internal computation and the equivalent value is limited within the range as shown below: 00000001h to 7FFFFFFFh (1 to 2147483647) When setting value is 0, it is changed to 1 by internal process and used for control.

7-5-2 Profile absolute positioning (Type_Code: 10h)

Set target position (absolute position) to TPOS. Servo driver performs positioning by internally generates position command.

Before executing, establish the home (return to home).

In the incremental mode, positioning can be done without determining the home, but be sure to read the servo driver internal position information beforehand to prevent movement to unintentional position.

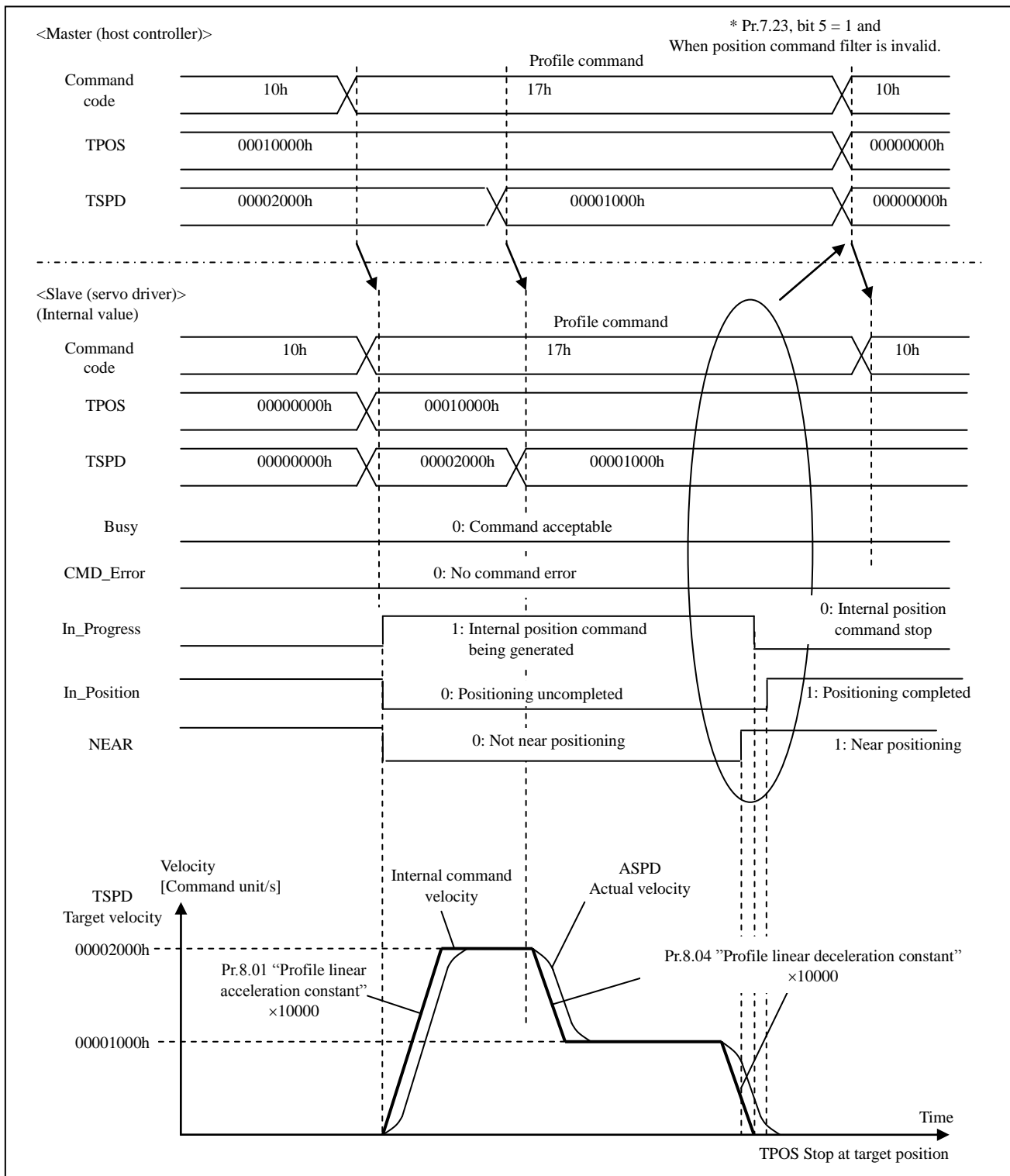

- 1) On the master (host controller), set command code to normal command (10h) of PP control. This does not directly trigger profile operation.
Before operating, set acceleration/deceleration through Pr8.01 “Profile linear acceleration constant”/Pr8.04 “Profile linear deceleration constant”.
- 2) With command code 10h, set Type_Code to 10h, target position (TPOS) and target speed (TSPD). Set the target position as absolute position.
Select data to be returned to Monitor_Data in Latch_Sel1 0 and Monitor_Sel.
This does not directly trigger profile operation.
- 3) Change command code from 10h to 17h.
- 4) The servo driver starts the profile operation as the command code is changed from 10h to 17h, starting acceleration (starting operation) to the target velocity (TSPD).
- 5) On the host controller check that command echo is 17h, Type_Code echo is 10h and status In_Progress is 1, and no command error has occurred and absolute positioning has started. If command error has occurred, take proper counter measure according to the error code.

- 6) When changing the target position (TPOS)/target speed (TSPD) during operation, follow the procedure shown below.

- Pr.7.23, bit 5 = 0: start as reference command changes
With command code 10h, change the target position (TPOS)/target speed (TSPD) value, and return to step 3).
- Pr.7.23, bit 5 = 1: start as command code and command argument change
With command code 17h, change the target position (TPOS)/target speed (TSPD) value.

If the new target position (TPOS) is near than the current internal command position (before filtering: IPOS), decelerate and stop according to Pr.8.04 and then accelerate to the new target position (TPOS).

If the new target speed (TSPD) is larger than the current command speed, accelerate according to Pr.8.01, and if TSPD is smaller than the current command speed, decelerate according to Pr8.04.

- 7) Then decelerate toward the target position (TPOS) at the rate set by Pr8.04.
- 8) When the distance from internal command position (IPOS) to the target position becomes shorter than Pr7.15 “Positioning adjacent range”, NEAR becomes 1 (profile positioning neighborhood). After outputting movement to target position command, the servo driver sets status In_Progress to 0 (transfer complete). As the absolute value of position deviation decreases below Pr4.31 “Positioning complete range”, the driver sets In_Position to 1 and informs the host controller that the positioning has completed.

■ Precautions

- Other non-cyclic commands except for certain homing commands may be executed during operation (`In_Progress = 1`) while maintaining profile operation. However, do not change the operation mode (`Type_Code`, `Latch_Sel1` of profile command), otherwise, Err91.1 “RTEX command error protection” and command error (0104h) will occur.
- If target speed (TSPD) is set at 0 or if Pause is set at 1, `In_Progress` will not be set to 0 (Internal position command stop) after deceleration and stop. To end the process during operation, transmit `Hard_Stop` or `Smooth_Stop`, then, `In_Progress` will be set to 0 (transfer complete) at stop.
- If the command position input when the single-turn absolute function is effective has become out of the setting range, a command error (0033h) will be returned. For details of the command position setting range, refer to Technical Reference Functional Specification “Section 6-6”.
- If the command position input when the infinitely rotatable absolute function is effective becomes out of the set range, command error (0033h) will be returned.
Reference Functional Specification “Section 6-7”.

7-5-3 Profile relative positioning (Type_Code: 11h)

Specify relative movement distance to TPOS and the servo driver performs positioning by internally generating position command. To prevent movement to unintentional position, read servo driver internal command position (before filtering: IPOS) while internal command generation is paused (In_Progress = 0) in PP control mode, before starting operation.

Note: Internal command position (IPOS) changes by following motor position during servo off, velocity control (CV) and torque control (CT).

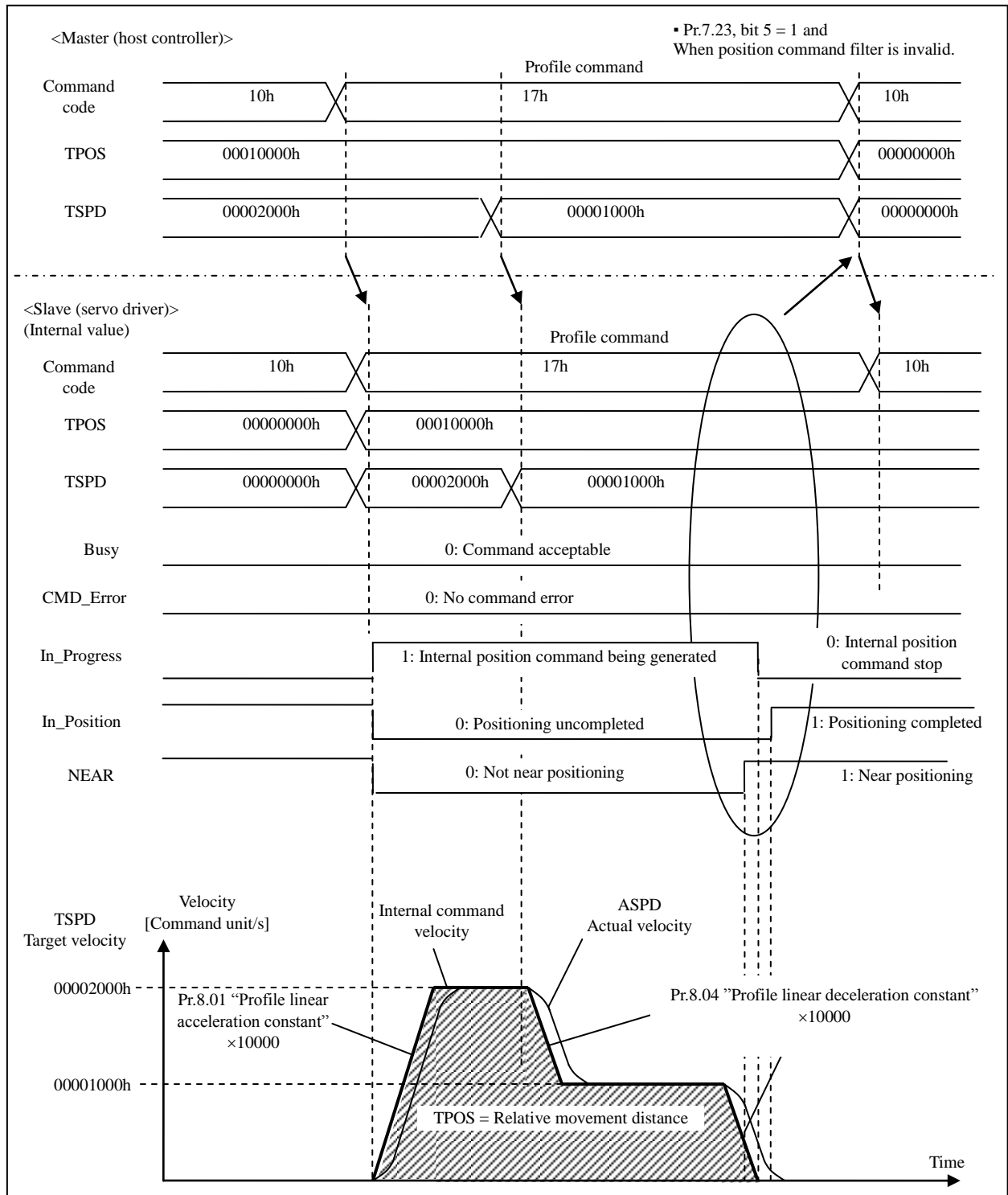

- 1) On the host controller, set command code to normal command (10h) of PP control.
This setting does not directly trigger profile operation.
Before operating, set acceleration/deceleration according to Pr8.01 “Profile linear acceleration constant” and Pr8.04 “Profile linear deceleration constant”.
- 2) With command code 10h, set Type_Code to 11h, relative movement distance (TPOS) and target speed (TSPD). Set Latch_Sel1 to 0, and for Monitor_Sel, select data to be returned to Monitor_Data.
This does not directly trigger profile operation.
- 3) Change command code from 10h to 17h.
- 4) As command code changes from 10h to 17h, the servo driver sets the internal target position to the value shown below, starts profile operation and accelerates (starts operation) to the target speed (TSPD).

Internal target position = internal command position (before filtering: IPOS) + relative movement distance (TPOS)

- 5) The host controller checks that command echo is 17h, Type_Code echo is 11h and status In_Progress is 1, and no command error has occurred and relative positioning has started. If command error has occurred, take proper countermeasure according to the error code.
- 6) When changing the target speed (TSPD), follow the procedure shown below.

- Pr.7.23, bit 5 = 0: start as reference command changes
With command code 10h, change the target speed (TSPD) value, and return to step 3).
- Pr.7.23, bit 5 = 1: start as command code and command argument change
With command code 17h, change the target speed (TSPD) value.

If the new target speed (TSPD) is higher than the current command speed, accelerate the current speed according to setting in Pr.8.01 and, if new TSPD is lower than the current command speed, decelerate the current speed according to Pr.8.04.

- 7) Then decelerate toward the internal target position at a rate set by Pr8.04.
- 8) When the distance from internal command position (IPOS) to the target position becomes shorter than Pr7.15 “Positioning adjacent range”, NEAR becomes 1 (profile positioning neighborhood). After outputting the movement to internal target position command, the servo driver sets status In_Progress to 0 (transfer complete). As the absolute value of position deviation decreases below Pr4.31 “Positioning complete range”, the driver sets In_Position to 1 and informs the host controller that the positioning has completed.

■ Precautions

- Other non-cyclic commands except for homing command may be executed during operation (`In_Progress = 1`) while maintaining profile operation. However, do not change the operation mode (`Type_Code`, `Latch_Sel1` of profile command), otherwise, Err91.1 “RTEX command error protection” and command error (0104h) will occur.
- Do not change relative movement distance (TPOS) during operation. For relative movement, internal target position is calculated with reference to the internal command position (IPOS) at the time the currently operating command is started (in Step 4) above.
- When target speed (TSPD) is set at 0 or Pause is set at 1, `In_Progress` will not be set to 0 (Internal position command stop) at the stop after deceleration. To end the process during operation, transmit `Hard_Stop` or `Smooth_Stop`, then, `In_Progress` will be set to 0 (transfer complete) at stop.
- If the command position input when the single-turn absolute function is effective has become out of the setting range, a command error (0033h) will be returned. For details of the command position setting range, refer to Technical Reference Functional Specification “Section 6-6”.

7-5-4 Profile position latch absolute positioning (Type_Code: 12h)

Specify the target position (absolute position) to TPOS and the servo driver performs positioning by internally generating position command. During positioning, it updates the target position upon detecting latch signal.

Perform the positioning after establishing home (after completion of return-to-home).

To prevent movement to unintentional position, read position information from the servo driver although the positioning can be started before determining the home in the incremental mode.

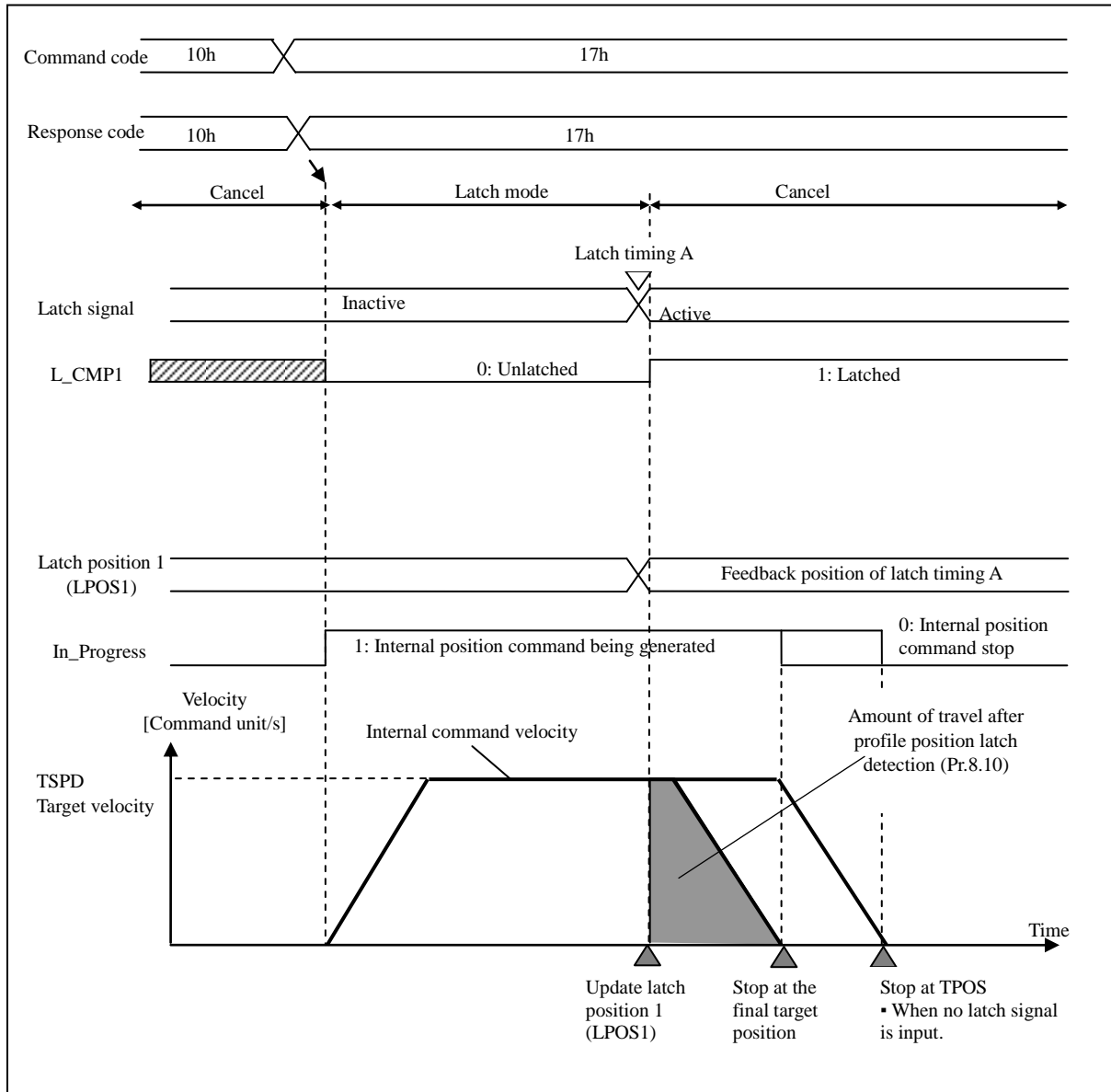

- 1) On the host controller, set command code to normal command (10h) of PP control.
This setting does not directly trigger profile operation.
Before starting operation, set acceleration/deceleration according to Pr8.01 “Profile linear acceleration constant” and Pr8.04 “Profile linear deceleration constant”; set distance of movement after detection of latch signal according to Pr8.10 “Amount of travel after profile position latch detection”.
- 2) With command code 10h, set Type_Code to 12h, target position (absolute position) (TPOS) and target speed (TSPD).
Select latch trigger signal as Latch_Sel1 and for Monitor_Sel select data to be returned to Monitor_Data.
This does not directly trigger profile operation.
- 3) Change command code from 10h to 17h.
- 4) As command code changes from 10h to 17h, the servo driver starts profile operation and accelerates (starts operation) to the target speed (TSPD).
- 5) The host controller checks that command echo is 17h, Type_Code echo is 12h and status In_Progress is 1, and no command error has occurred and absolute positioning has started. If command error has occurred, take proper counter measure according to the error code.
- 6) Upon detecting latch trigger signal, update the internal target position as follows:

Internal target position = Latch position 1 (LPOS1) + Amount of travel after profile position latch detection (Pr.8.10)
--
- 7) Then decelerate toward the internal target position at the rate set according to setting of Pr8.04.
- 8) When the distance from internal command position (IPOS) to the target position becomes shorter than Pr7.15 “Positioning adjacent range”, NEAR becomes 1 (profile positioning neighborhood). After outputting movement to target position command, the servo driver sets status In_Progress to 0 (transfer complete). As the absolute value of position deviation decreases below Pr4.31 “Positioning complete range”, the driver sets In_Position to 1 and informs the host controller that the positioning has completed.

■ Precautions

- Other non-cyclic commands except for homing command may be executed during operation (In_Progress = 1) while maintaining profile operation. However, do not change the operation mode (Type_Code, Latch_Sel1 of profile command), otherwise, Err91.1 “RTEX command error protection” and command error (0104h) will occur.
- When target speed (TSPD) is set at 0 or Pause is set at 1, In_Progress will not be set to 0 (Internal position command stop) at the stop after deceleration. To end the process during operation, transmit Hard_Stop or Smooth_Stop, and In_Progress will be set to 0 (transfer complete) at stop.
- The operation after detection of latch signal input position is as shown below depending on the positioning direction and the sign of parameter Pr8.10 “Amount of travel after profile position latch detection”.

		Sign of Pr.8.10	
		Positive number	Negative number
Position latch Positioning direction	Positive direction	Stop after moving in positive direction (See Note)	Stop after deceleration and reverse direction and move in negative direction and then stop
	Negative direction	Stop after deceleration and reverse direction and move in positive direction and then stop	Stop after moving in negative direction (See Note)

Note: When the movement distance after detection of profile position latch is short for deceleration distance, reverse will occur after deceleration and stop.

- The latch position 1 (LPOS1) and position latch complete 1 (L_CMP1) will be maintained until the subsequent latch process starts or latch mode is canceled. However, upon initialization of position information or resetting of control power source or if communication is not established, latch position 1 (LPOS1) is undefined: repeat the latch process.
- When repeating position latching, transmit normal command (10h) after position latching and then start the subsequent latching process.
- When external latch input signal is used, latch position 1 (LPOS1) is not correctly read. To minimize the error rate, lower the speed around latch signal input as low as possible.
- Be sure to maintain the value of the latch signal (Latch_Sel1) while processing this command (latch detection process).
- If the target position is reached without detection of latch signal, latch status will be held.
- If the command position input when the single-turn absolute function is effective has become out of the setting range, a command error (0033h) will be returned. For details of the command position setting range, refer to Technical Reference Functional Specification “Section 6-6”.
- If the command position input by absolute position command when the infinitely rotatable absolute function is effective becomes out of the set range, command error (0033h) will be returned. Reference Functional Specification “Section 6-7”.

7-5-5 Profile position latch relative positioning (Type_Code: 13h)

Specify the relative movement distance to TPOS and the servo driver performs positioning by internally generating position command. During positioning, it updates the target position upon detecting latch signal.

To prevent movement to unintentional position, read command position (before filtering: IPOS) from the servo driver while pausing internal command generation (In_Progress = 0) in the PP control mode.

Note: The internal command position (IPOS) will vary with the motor position during servo off, velocity control (CV) and torque control (CT).

This positioning differs from the profile position latch absolute positioning in Type_Code at starting and in specifying method of target position (TPOS).

For details of operation of the profile position latch absolute positioning, refer to 7-5-4.

7-5-6 Profile continuous revolution (JOG) (Type_Code: 20h)

In this mode, target position (TPOS) is not specified but target speed (TSPD) is specified; and positioning starts as the servo driver internally generates position command and continues revolution (JOG) until stop command is given.

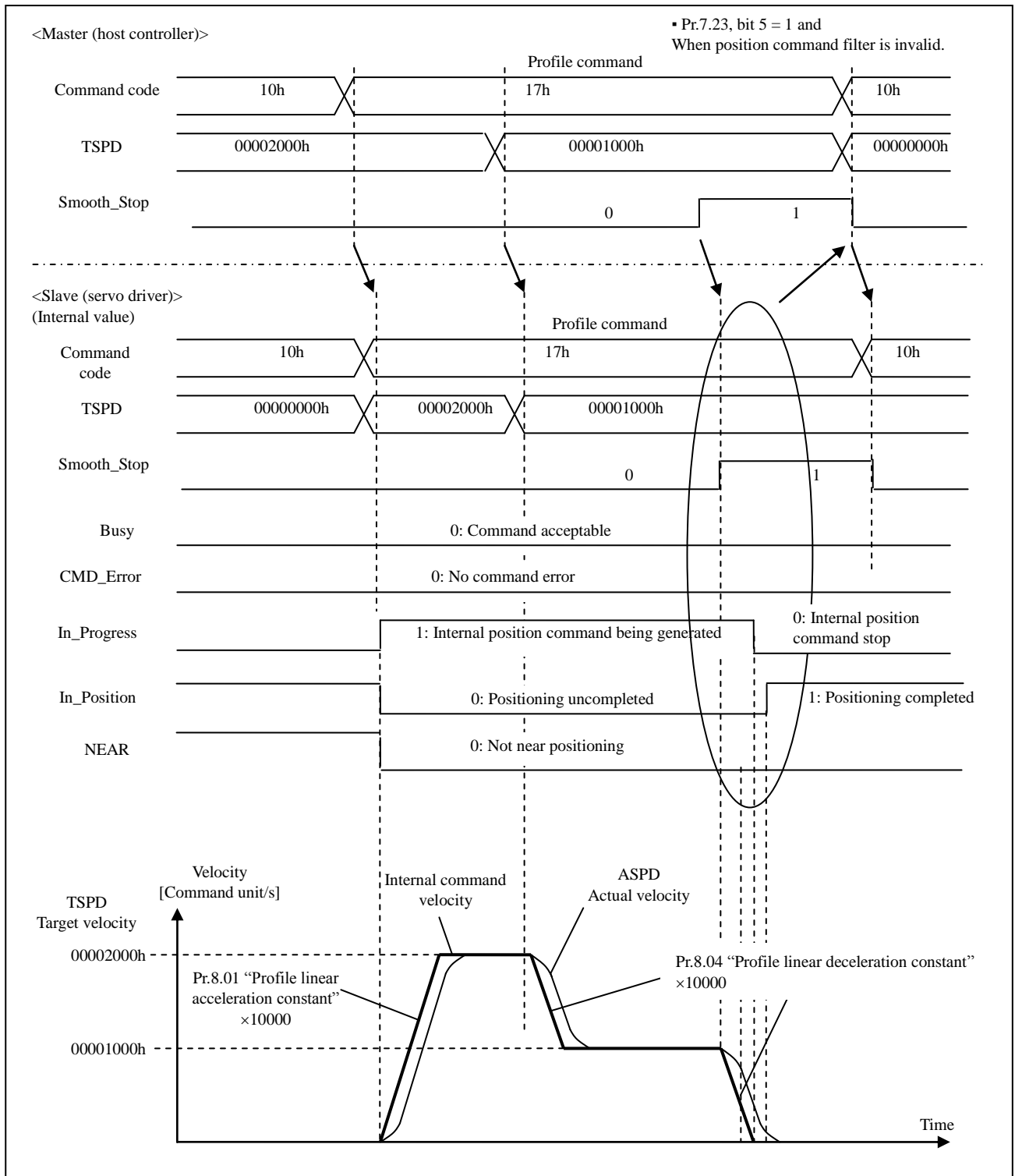

- 1) On the master (host controller), set command code to normal command (10h) of PP control. This does not directly trigger profile operation.
Before operating, set acceleration/deceleration through Pr8.01 “Profile linear acceleration constant”/Pr8.04 “Profile linear deceleration constant”.
- 2) With command code 10h, set Type_Code to 20h and target speed (TSPD).
Set the target position (TPOS) to 0 because it is not used.
Set 0 to Latch_Sel1, select data to be returned to Monitor_Data in Monitor_Sel.
This does not directly trigger profile operation.
- 3) Change command code from 10h to 17h.
- 4) The servo driver starts the profile operation as the command code is changed from 10h to 17h, starting acceleration (starting operation) to the target velocity (TSPD).
- 5) The host controller checks that command echo is 17h, Type_Code echo is 20h and status In_Progress is 1, and no command error has occurred and absolute positioning has started. If command error has occurred, take proper counter measure according to the error code.
- 6) When changing the target speed (TSPD), follow the procedure shown below.

- Pr.7.23, bit 5 = 0: start as reference command changes
With command code 10h, change the value of target speed (TSPD), and return to step 3).
- Pr.7.23, bit 5 = 1: start as command code and command argument change
With command code 17h, change the value of target speed (TSPD).

If the new target speed (TSPD) is larger than the current command speed, accelerate it according to Pr.8.01, or if new TSPD is smaller, decelerate it according to Pr8.04.

- 7) To stop immediately, set Hard_Stop to 1; to decelerate according to setting of Pr8.04, set Smooth_Stop or Pause to 1.
 - 8) While operating in profile continuous revolution (JOG) mode, NEAR remains 0 because no target position is set.
After outputting the movement command, the servo driver sets In_Progress to 0 (transfer complete), and as the absolute value of position deviation decreases below Pr4.31 “Positioning complete range”, the driver sets In_Position to 1 and informs the host controller that the positioning has completed.
- Precautions
- Other non-cyclic commands (e.g. monitor command) may be executed during operation (In_Progress = 1) while maintaining profile operation. However, do not change the operation mode (Type_Code, Latch_Sel1 of profile command), otherwise, Err91.1 “RTEX command error protection” and command error (0104h) will occur.
 - If Pause is set at 1, In_Progress will not be set to 0 (Internal position command stop) at the stop after deceleration. To end the process during operation, transmit Hard_Stop or Smooth_Stop, then, In_Progress will be set to 0 (transfer complete) at stop.

7-5-7 Profile homing 1 (HOME + Z phase) (Type_Code: 31h)

This return-to-home process uses Z phase from HOME sensor as the trigger signal.

In this system, the position of the first Z phase after the HOME sensor in homing direction detected the rising edge is denoted as the home position.

As the unit stops at the home position, the position information is initialized so that the position is set to 0.

Direction of homing (positive/negative) can be set according to Pr8.12 “Profile return to home position mode setup”.

■ Example: Pr.8.12 = 0 (Homing direction = positive direction trigger signal detection)

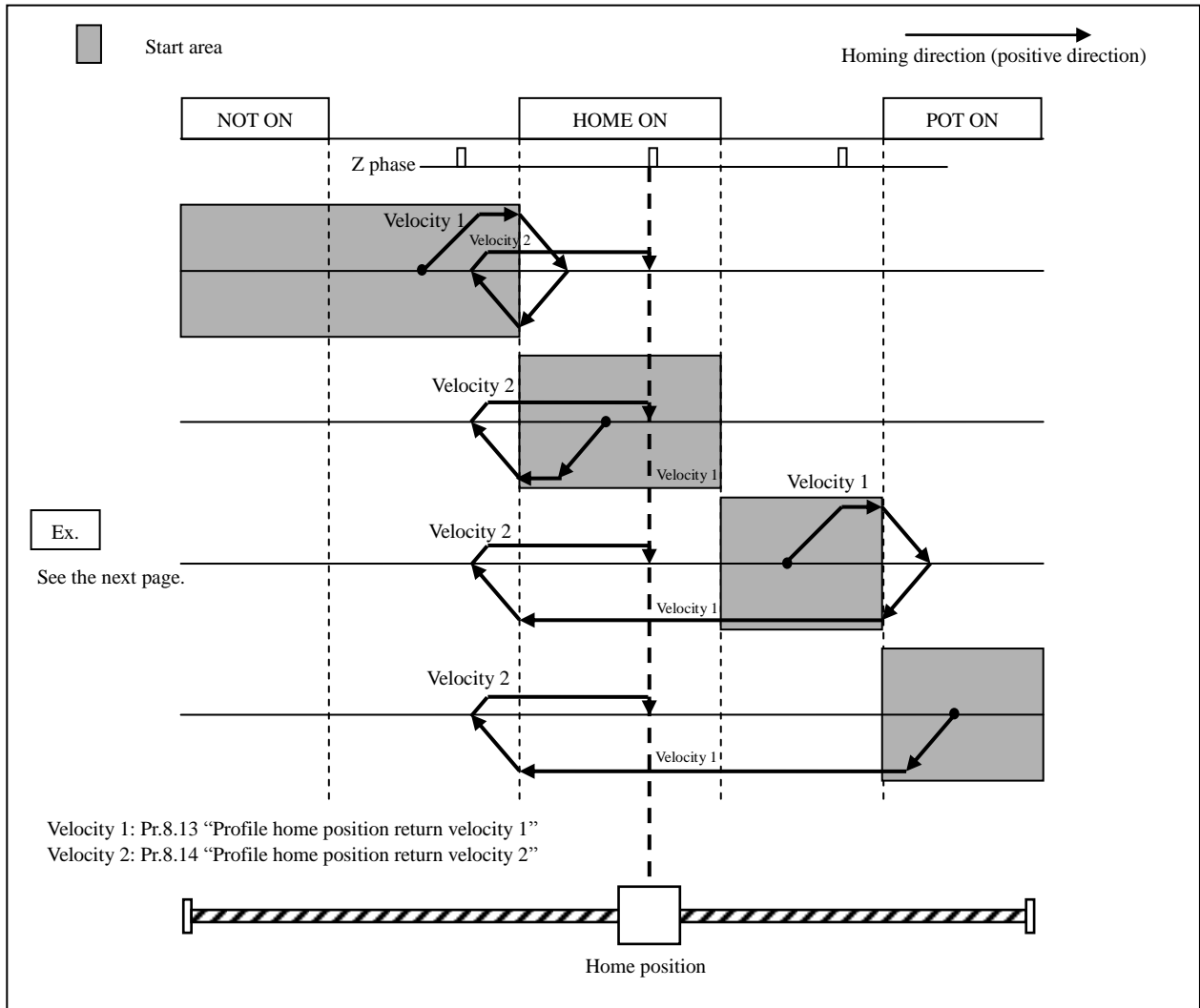

Example: Pr8.12 = 0 (Positive direction trigger signal detection)—homing is started at a position more negative than HOME sensor

- 1) The host controller sets the command code to normal command (10h) of PP control.
This does not start the profile operation.
Parameters related to acceleration/deceleration (Pr8.01/Pr8.04) and homing (Pr8.12–Pr8.14) should be set before starting operation.
- 2) With normal command (10h) condition, set Type_Code to 31h.
Set target position (TPOS) and target speed (TSPD) to 0 because they are not used.
Set Latch_Sel1 to 0. For Monitor_Sel, select data to be returned to Monitor_Data.
This does not directly start profile operation.
- 3) Change command code 10h to 17h.
- 4) The servo driver starts profile operation as command code 10h changes to 17h, accelerates operation (starts operation) according to Pr8.01 “Profile linear acceleration constant” to reach Pr8.13 “Profile home position return velocity 1”. Note that upon starting the profile operation, Homing_Complete is set to 0.
- 5) The host controller checks that command code echo is 17h, Type_Code echo is 31h and status In_Progress is 1, and no command error has been generated, and homing operation has started. If command error is detected, the controller should take appropriate countermeasure according to the error code.
- 6) When POT is detected before HOME sensor detection, start deceleration according to Pr8.04 “Profile linear deceleration constant” to stop.
- 7) At the stop position, start movement in the direction opposite to the homing at the speed specified by Pr8.13.
- 8) When HOME sensor turns on and then OFF edge is detected, start deceleration at the rate specified by Pr8.04.
- 9) At the stop position, start movement in the homing direction, accelerating according to Pr8.14 “Profile home position return velocity 2”, re-entering HOME sensor area and stop upon detecting the 1st Z phase.
 - Actually, detected position is determined by repositioning.
- 10) Initialize the position information so that the detected Z phase becomes 0 and Homing_Complete becomes 1, and profile homing is finished.

■ Precautions

- If Z phase is close to a point where HOME changes, the 1st Z phase may not be detected as home due to reading delay of HOME sensor. Place Z phase far away from the point where HOME sensor changes the output.
- Sensors (HOME, POT, NOT) should be so arranged that once they detect something, nothing will pass through them until deceleration and stop complete.
- During profile homing 1 (HOME + Z phase), Pr5.04 “Over-travel inhibit input setup” and Pr5.05 “Sequence at over-travel inhibit” are temporarily disabled. When POT/NOT is detected, reverse operation will automatically start after deceleration and stop.
When using this function without using the over-travel inhibit input, do not allocate POT/NOT to general purpose input. Simply setting Pr5.04 to 1 will not disable the function.
- If an error occurs during homing, e.g. the sensor cannot detect the home during reverse operation due to the over-travel inhibit input and detects the over-travel inhibit input ON of reverse side, or, if both of over-travel inhibit inputs are ON state, Err94.2 “Homing error protection” will occur, canceling homing process.
- Other non-cyclic commands except for homing commands may be executed during operation (until Homing_Ccomplete becomes 1) while maintaining profile operation. However, do not change the operation mode (Type_Code, Latch_Sel1 of profile command), otherwise, Err91.1 “RTEX command error protection” and command error (0104h) will occur.

7-5-8 Profile homing 2 (HOME) (Type_Code: 32h)

This homing sequence uses HOME sensor as the trigger signal.

Home position is defined as the point where HOME sensor detects the rising edge in return-to-home direction. After stopping at the home position, initialize the position information so that this position is set at 0.

Only positive homing direction is supported.

Set Pr8.12 “Profile return to home position mode setup” to 0.

Setting Pr8.12 to 1 also causes homing in positive direction.

If POT/NOT is detected in the same direction of the direction of home position return, Err94.2 “Home position return error protection” occurs and home position return processing is cancelled.

■ Example: Pr8.12 = 0 (Homing direction = positive direction trigger signal detection)

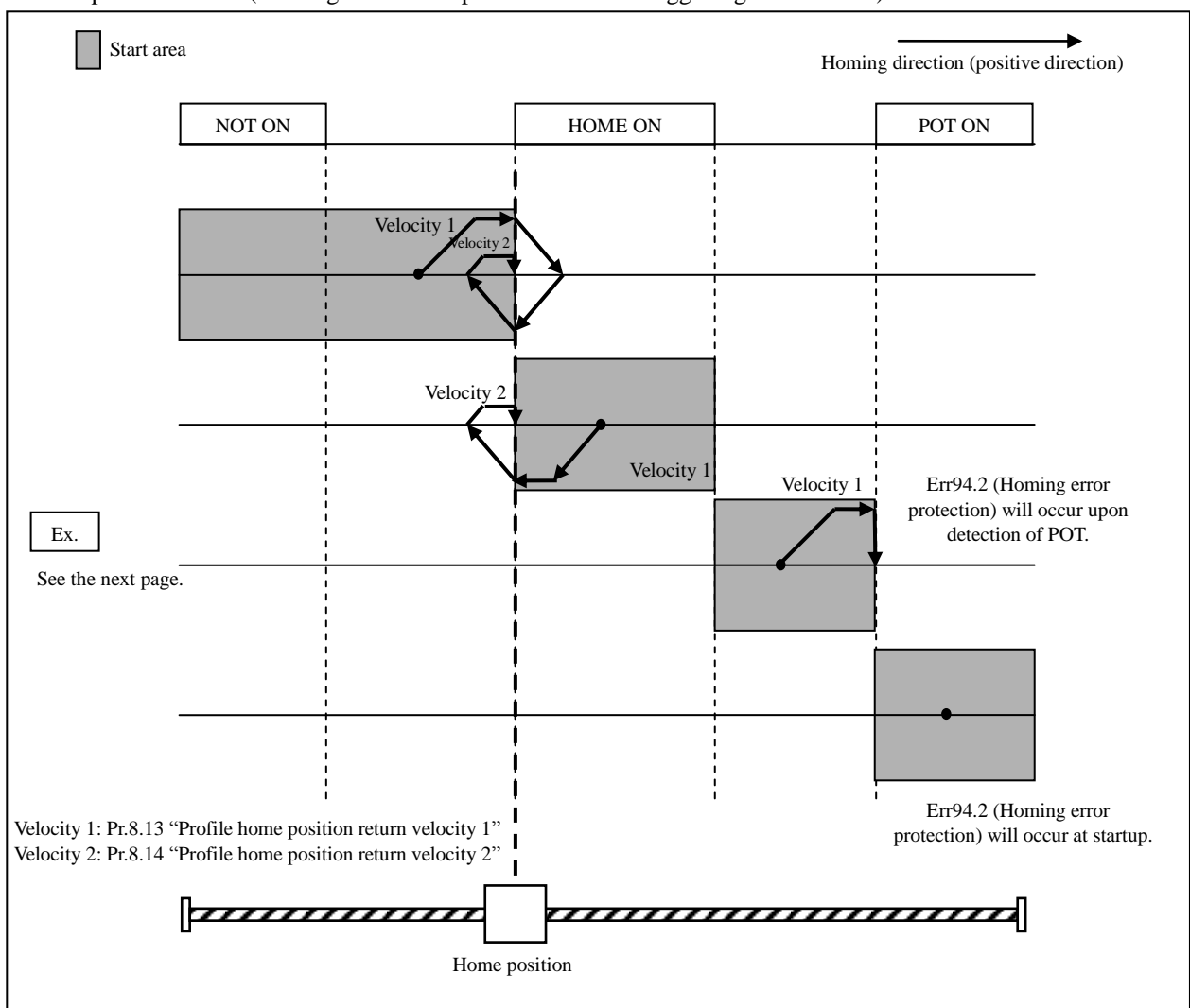

Example: Pr8.12 = 0 (Positive direction trigger signal detection)—homing is started at a position more negative than HOME sensor

- 1) The host controller sets the command code to normal command (10h) of PP control.
This does not start the profile operation.
Parameters related to acceleration/deceleration (Pr8.01/Pr8.04) and homing (Pr8.12–Pr8.14) should be set before starting operation.
- 2) With normal command (10h) condition, set Type_Code to 32h.
Set target position (TPOS) and target speed (TSPD) to 0 because they are not used.
Set Latch_Sel1 to 0. For Monitor_Sel, select data to be returned to Monitor_Data.
This does not directly start profile operation.
- 3) Change command code 10h to 17h.
- 4) The servo driver starts profile operation as command code 10h changes to 17h, accelerates operation (starts operation) according to Pr8.01 “Profile linear acceleration constant” to reach Pr8.13 “Profile home position return velocity 1”. Note that upon starting the profile operation, Homing_Complete is set to 0.
- 5) The host controller checks that command code echo is 17h, Type_Code echo is 32h and status In_Progress is 1, and no command error has been generated, and homing operation has started. If command error is detected, the controller should take appropriate countermeasure according to the error code.
- 6) When HOME sensor turns on, start deceleration according to Pr8.04 “Profile linear deceleration constant” to stop.
- 7) At the stop position, start movement in the direction opposite to the homing at the speed specified by Pr8.13.
- 8) When HOME sensor turns on and then OFF edge is detected, start deceleration at the rate specified by Pr8.04.
- 9) At the stop position, start movement in the homing direction, accelerating according to Pr8.14 “Profile home position return velocity 2”, and stop at the position where HOME sensor ON (rising edge) is detected.
 - Actually, detected position is determined by repositioning.
- 10) Initialize the position information so that the detected HOME sensor rising edge is at 0 and Homing_Complete becomes 1, and profile homing is finished.

■ Precautions

- Set Pr8.14 “Profile home position return velocity 2” to the lowest possible velocity. Higher velocity may cause error due to delay in reading.
- HOME sensors should be so arranged that once they detect something, nothing will pass through them until deceleration and stop complete.
- During profile homing 2 (HOME + Z phase), when the detected POT/NOT and the direction of homing are the same direction, Err94.2 “Homing error protection” will occur and cancel homing process. When using this function without using the over-travel inhibit input, do not allocate POT/NOT to general purpose input. Simply setting Pr5.04 to 1 will not disable the function.
- Other non-cyclic commands except for homing commands may be executed during operation (until Homing_Ccomplete becomes 1) while maintaining profile operation. However, do not change the operation mode (Type_Code, Latch_Sel1 of profile command), otherwise, Err91.1 “RTEX command error protection” and command error (0104h) will occur.

7-5-9 Profile homing 3 (Z phase) [Type_Code: 33h]

This homing sequence uses Z phase as the trigger signal.

Define the 1st Z phase position in the homing direction as the home position.
 Stop at the home and initialize the position information to set this position at 0.

Direction of homing can be set to either positive or negative through the setting of Pr8.12 “Profile return to home position mode setup”.

If POT/NOT is detected in the same direction of the direction of home position return, Err94.2 “Home position return error protection” occurs and home position return processing is cancelled.

■ Example: Pr.8.12 = 0 (Homing direction = positive direction trigger signal detection)

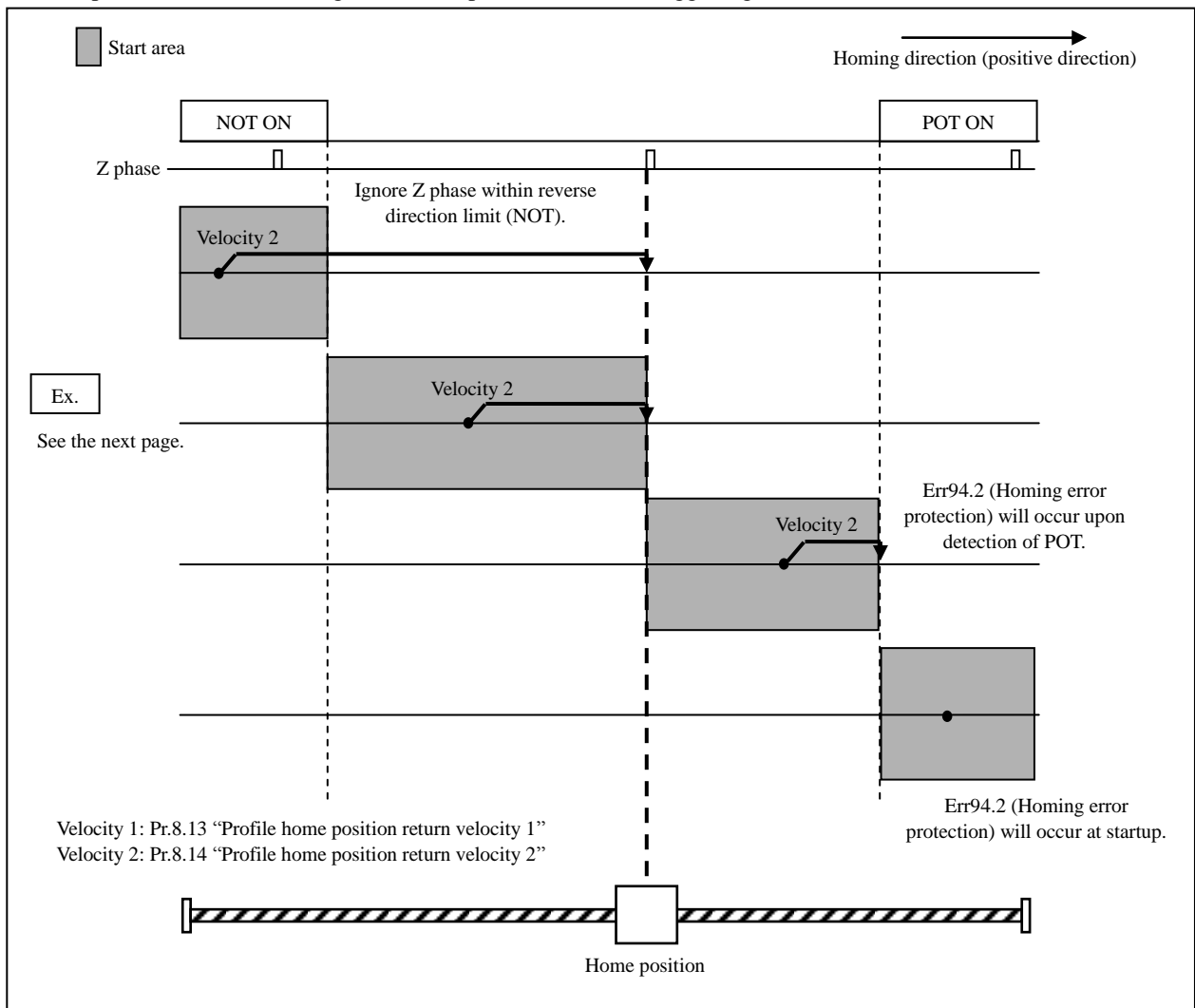

Example: Pr8.12 = 0 (Positive direction trigger signal detection)—homing is started at a position more negative than Z phase

- 1) The host controller sets the command code to normal command (10h) of PP control.
This does not start the profile operation.
Parameters related to acceleration/deceleration (Pr8.01/Pr8.04) and homing (Pr8.12–Pr8.14) should be set before starting operation.
- 2) With normal command (10h) condition, set Type_Code to 33h.
Set target position (TPOS) and target speed (TSPD) to 0 because they are not used.
Set Latch_Sel1 to 0. For Monitor_Sel, select data to be returned to Monitor_Data.
This does not directly start profile operation.
- 3) Change command code 10h to 17h.
- 4) The servo driver starts profile operation as command code 10h changes to 17h, accelerates operation (starts operation) according to Pr8.01 “Profile linear acceleration constant” to reach Pr8.14 “Profile home position return velocity 2”. Note that upon starting the profile operation, Homing_Complete is set to 0.
- 5) The host controller checks that command code echo is 17h, Type_Code echo is 33h and status In_Progress is 1, and no command error has been generated, and homing operation has started. If command error is detected, the controller should take appropriate countermeasure according to the error code.
- 6) Stop at the position where the 1st Z phase is detected.
 - Actually, detected position is determined by repositioning.
- 7) Initialize the position information to set the detected Z phase position to 0, and set Homing_Complete to 1 to finish profile homing sequence.

■ Precautions

- When the detected direction of drive inhibit input and the direction of homing are the same, Err94.2 “Homing error protection” will occur, disabling reversal of movement direction.
- When the detected direction of drive inhibit input is opposite to the homing direction, Z phase is not detected or ignored.
- During profile homing 3 (Z phase), when the detected POT/NOT and the direction of homing are the same direction, Err94.2 “Homing error protection” will occur and cancel homing process.
When using this function without using the over-travel inhibit input, do not allocate POT/NOT to general purpose input. Simply setting Pr5.04 to 1 will not disable the function.
- Other non-cyclic commands except for homing commands may be executed during operation (until Homing_Ccomplete becomes 1) while maintaining profile operation. However, do not change the operation mode (Type_Code, Latch_Sel1 of profile command), otherwise, Err91.1 “RTEX command error protection” and command error (0104h) will occur.
- When the Z-phase width is great, there may be the wrong detection evaluating that the amount of deceleration travel is smaller than the Z-phase width.
Adjust the amount of deceleration travel using Pr8.04 “Profile linear deceleration constant” to allow for a margin that provides a sufficiently greater amount than the Z-phase width.
- When there is more than one Z phase, this home position return method may not be able to detect a desired Z phase. Therefore, have one Z phase or use the home position return method that combines the use of the HOME sensor (Type_Code=31h).

7-5-10 Profile homing 4 (POT/NOT + HOME) (Type_Code: 34h)

This homing sequence uses HOME sensor as the trigger signal.

Home position is defined as the point where HOME sensor detects the rising edge in return-to-home direction. After stopping at the home position, initialize the position information so that this position is set at 0.

Only positive homing direction is supported.

Set Pr8.12 “Profile return to home position mode setup” to 0.

Setting Pr8.12 to 1 also causes homing in positive direction.

If POT/NOT is detected in the same direction of the direction of home position return, reversal operation automatically starts after a deceleration to stop, and then home position return processing continues.

■ Example: Pr8.12 = 0 (Homing direction = positive direction trigger signal detection)

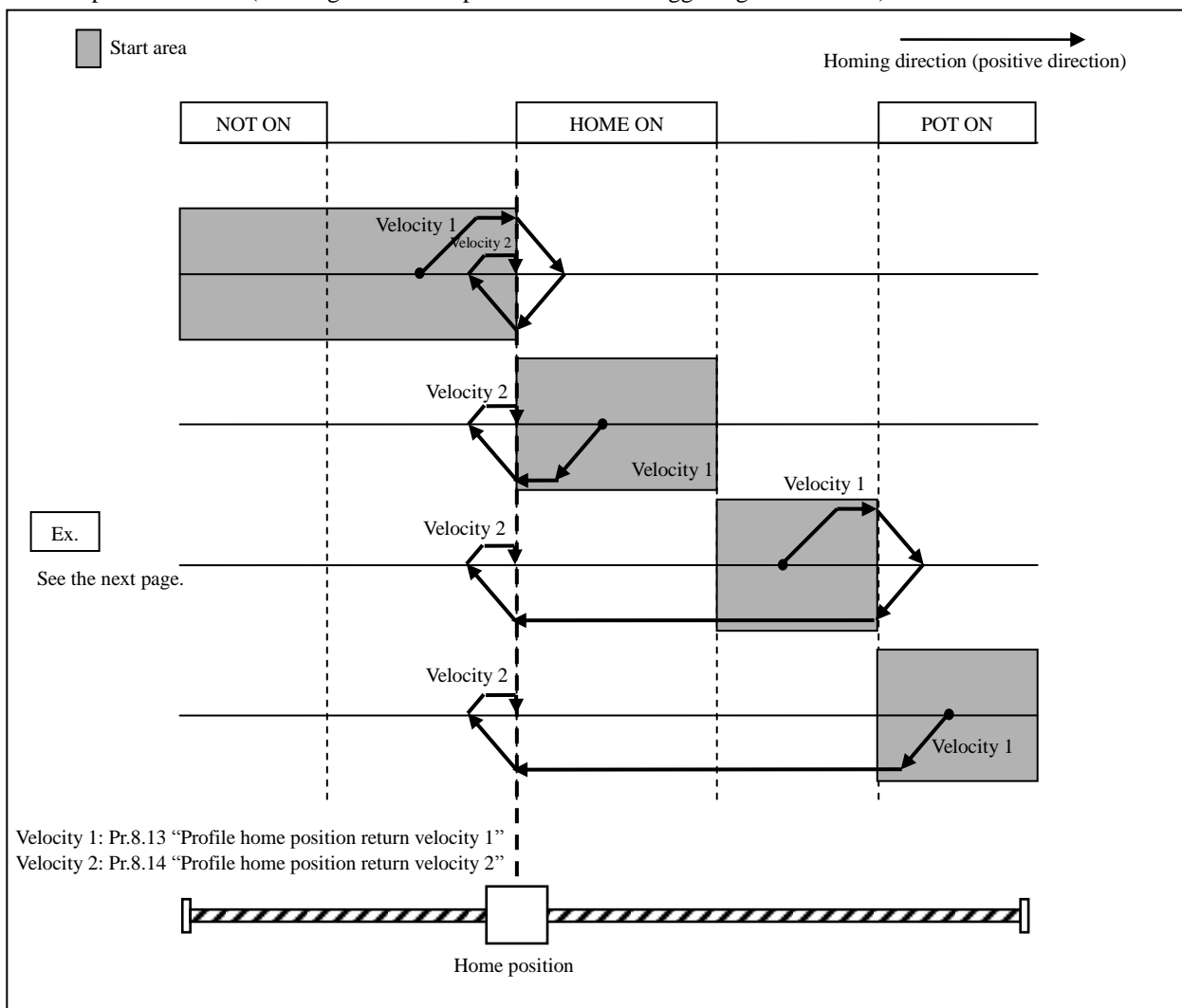

Example: Pr8.12 = 0 (Positive direction trigger signal detection)—homing is started at a position more negative than HOME sensor

- 1) The host controller sets the command code to normal command (10h) of PP control.
This does not start the profile operation.
Parameters related to acceleration/deceleration (Pr8.01/Pr8.04) and homing (Pr8.12–Pr8.14) should be set before starting operation.
- 2) With normal command (10h) condition, set Type_Code to 34h.
Set target position (TPOS) and target speed (TSPD) to 0 because they are not used.
Set Latch_Sel1 to 0. For Monitor_Sel, select data to be returned to Monitor_Data.
This does not directly start profile operation.
- 3) Change command code 10h to 17h.
- 4) The servo driver starts profile operation as command code 10h changes to 17h, accelerates operation (starts operation) according to Pr8.01 “Profile linear acceleration constant” to reach Pr8.13 “Profile home position return velocity 1”. Note that upon starting the profile operation, Homing_Complete is set to 0.
- 5) The host controller checks that command code echo is 17h, Type_Code echo is 34h and status In_Progress is 1, and no command error has been generated, and homing operation has started. If command error is detected, the controller should take appropriate countermeasure according to the error code.
- 6) When HOME sensor turns on, start deceleration according to Pr8.04 “Profile linear deceleration constant” to stop.
- 7) At the stop position, start movement in the direction opposite to the homing at the speed specified by Pr8.13.
- 8) When HOME sensor turns on and then OFF edge is detected, start deceleration at the rate specified by Pr8.04.
- 9) At the stop position, start movement in the homing direction, accelerating according to Pr8.14 “Profile home position return velocity 2”, and stop at the position where HOME sensor ON (rising edge) is detected.
 - Actually, detected position is determined by repositioning.
- 10) Initialize the position information so that the detected HOME sensor rising edge is at 0 and Homing_Complete becomes 1, and profile homing is finished.

■ Precautions

- Set Pr8.14 “Profile home position return velocity 2” to the lowest possible velocity. Higher velocity may cause error due to delay in reading.
- HOME sensors should be so arranged that once they detect something, nothing will pass through them until deceleration and stop complete.
- During profile home position return 4 (POT/NOT +HOME), the setup of Pr5.04 “Over-travel inhibit input setup” and Pr5.05 “Sequence at over-travel inhibit” is temporarily invalid. During POT/NOT detection, reversal operation is automatically started after a deceleration to stop.
When using this function without using the over-travel inhibit input, do not allocate POT/NOT to general purpose input. Simply setting Pr5.04 to 1 will not disable the function.
- If an error, such as the detection of drive disable input ON on the reverse side while failing to detect the home position during reversal operation with the drive disable setup or the drive disable input turned ON on both sides, is detected during home position return, Err94.2 “Home position return error protection” occurs and home position return processing is cancelled.
- Other non-cyclic commands except for homing commands may be executed during operation (until Homing_Ccomplete becomes 1) while maintaining profile operation. However, do not change the operation mode (Type_Code, Latch_Sel1 of profile command), otherwise, Err91.1 “RTEX command error protection” and command error (0104h) will occur.

7-5-11 Profile homing 6 (POT/NOT + Z phase) (Type_Code: 36h)

This homing sequence uses Z phase as the trigger signal.

The first Z phase position where the limit sensor is no longer detected, after reversal of operation by limit sensor detection in the return to origin direction, shall become the origin.

After stopping at the home position, initialize the position information so that this position is set at 0.

Direction of homing (positive/negative) can be set according to Pr8.12 “Profile return to home position mode setup”.

■ Example: Pr8.12 = 0 (Homing direction = positive direction trigger signal detection)

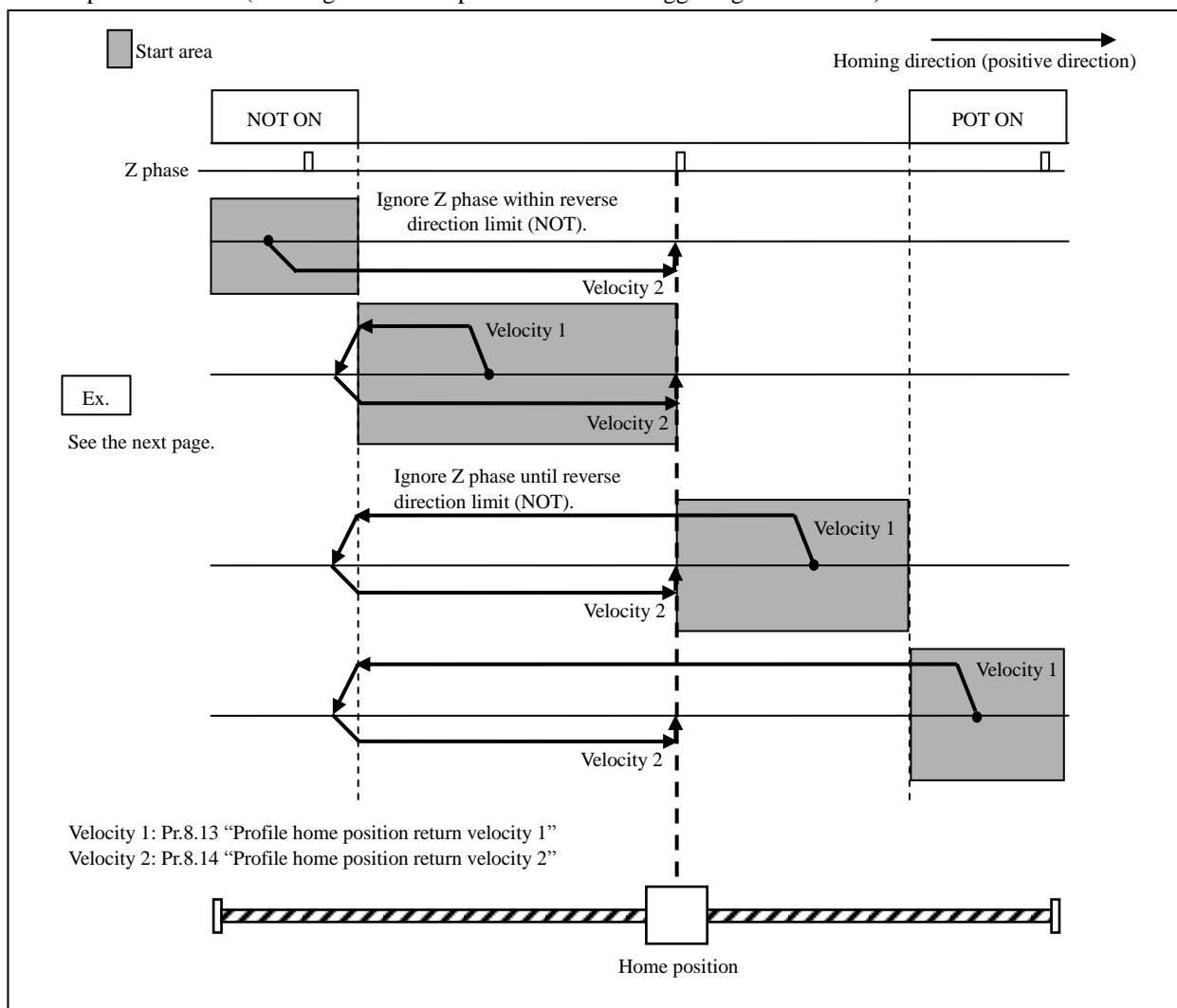

Example: Pr8.12 = 0 (Positive direction trigger signal detection)—homing is started at a position more positive than NOT sensor

- 1) The host controller sets the command code to normal command (10h) of PP control.
This does not start the profile operation.
Parameters related to acceleration/deceleration (Pr8.01/Pr8.04) and homing (Pr8.12–Pr8.14) should be set before starting operation.
- 2) With normal command (10h) condition, set Type_Code to 36h.
Set target position (TPOS) and target speed (TSPD) to 0 because they are not used.
Set Latch_Sel1 to 0. For Monitor_Sel, select data to be returned to Monitor_Data.
This does not directly start profile operation.
- 3) Change command code 10h to 17h.
- 4) The servo driver will start profile operation in the reverse direction of return to origin direction when the command code is changed from 10h to 17h, and will commence acceleration (operation start) under Pr8.01 “Profile linear acceleration constant” to reach Pr8.13 “Profile home position return velocity 1” Homing_Complete is once set to 0, as of the time of start.
- 5) The host controller checks that command code echo is 17h, Type_Code echo is 36h and status In_Progress is 1, and no command error has been generated, and homing operation has started. If command error is detected, the controller should take appropriate countermeasure according to the error code.
- 6) When NOT sensor turns on, start deceleration according to Pr8.04 “Profile linear deceleration constant” to stop.
- 7) After stopping, begin operation under the velocity of Pr8.14 “Profile home position return velocity 2” in the return to origin direction.
- 8) Stop at the position where the 1st Z phase is detected.
 - Actually, detected position is determined by repositioning.
- 9) Initialize the position information to set the detected Z phase position to 0, and set Homing_Complete to 1 to finish profile homing sequence.

■ Precautions

- During profile home position return 6 (POT/NOT + Z phase), the setup of Pr5.04 “Over-travel inhibit input setup” and Pr5.05 “Sequence at over-travel inhibit” is temporarily invalid. During POT/NOT detection, reversal operation is automatically started after a deceleration to stop.
- If an error, such as the detection of drive disable input ON on the reverse side while failing to detect the home position during reversal operation with the drive disable setup or the drive disable input turned ON on both sides, is detected during home position return, Err94.2 “Home position return error protection” occurs and home position return processing is cancelled.
- Other non-cyclic commands except for homing commands may be executed during operation (until Homing_Ccomplete becomes 1) while maintaining profile operation. However, do not change the operation mode (Type_Code, Latch_Sel1 of profile command), otherwise, Err91.1 “RTEX command error protection” and command error (0104h) will occur.
- When the Z-phase width is great, there may be the wrong detection evaluating that the amount of deceleration travel is smaller than the Z-phase width.
Adjust the amount of deceleration travel using Pr8.04 “Profile linear deceleration constant” to allow for a margin that provides a sufficiently greater amount than the Z-phase width.
- When there is more than one Z phase, this home position return method may not be able to detect a desired Z phase. Therefore, have one Z phase or use the home position return method that combines the use of the HOME sensor (Type_Code=31h).

7-5-12 Precautions for profile position control operation

- When relative displacement exceeds the following values, wraparound process is used.

Absolute encoder setup	Wraparound threshold [command unit]	
	lower limit	upper limit
Infinitely rotatable absolute encoder mode	0	$(2^{23} * Pr6.88 \text{ setting value}) - 1$
Other than infinitely rotatable absolute encoder mode	80000000h	7FFFFFFFh

<Example of wraparound process: As TPOS changes from 7FFFFFFFh to 80000000h
(Other than infinitely rotatable absolute encoder mode)>

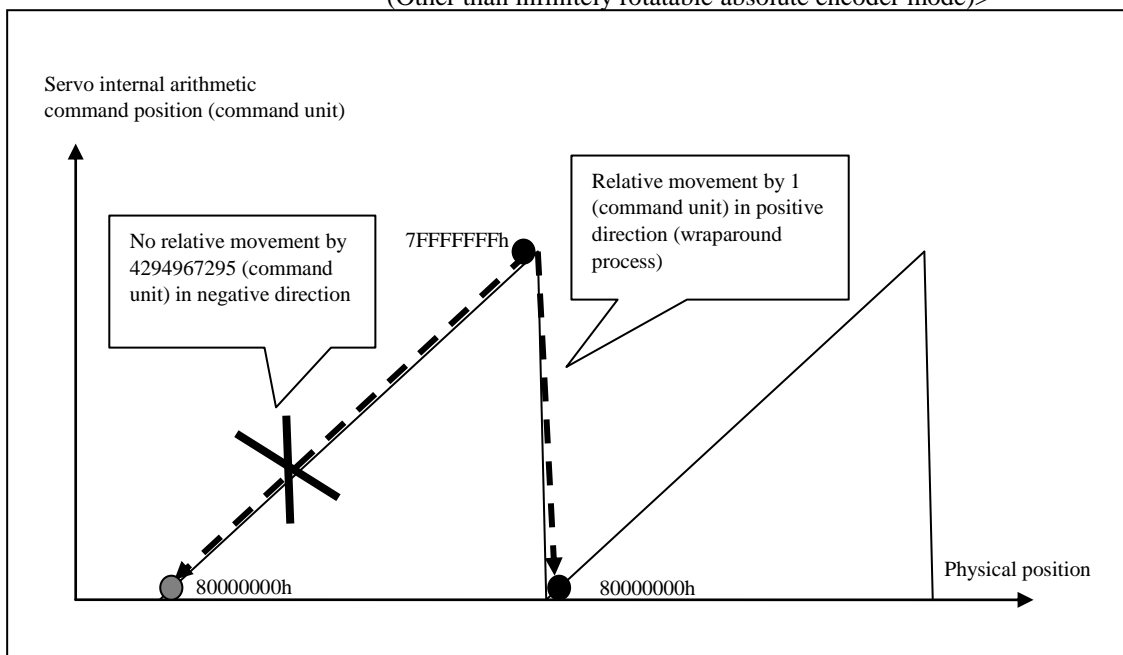

- When the latch trigger signal is applied from external source, it should be detected at the lowest possible speed. If it is detected at a higher speed, with very low electronic gear ratio (e.g. 1/1000), wraparound of detection position will occur upon reverse conversion to command unit (latch position is not exactly detected).
- When the target speed (TSPD) is set outside the range, it causes command error (0032h).
Maximum target speed will be the motor maximum speed or 7FFFFFFFh (command unit/s), whichever small.
Note: Motor maximum speed includes errors caused by rounding in calculating process and by electronic gear.
- During acceleration, deceleration will be started if continuous acceleration may cause movement beyond the target position. As a result, the speed may not reach the target speed (TSPD).
- When deceleration is made to the target speed which is slower than the current internal command speed, and even if the resulting speed difference is smaller than the difference between decelerations, deceleration is made according to the new deceleration rate and then acceleration will be made to attain the target speed. If this process causes problem, take corrective measure, e.g. decrease Pr8.04 "profile linear deceleration constant".

- The speed (including initial speed upon changing control mode) at the start of deceleration and Pr8.04 “profile linear deceleration constant” shall meet the following restriction.

<Restriction>

Amount of movement distance (P) necessary to decelerate from the initial speed to the target speed < 7FFFFFFFh (command unit)

For example, if the initial speed upon switching from the cyclic torque control does not meet the restriction, Err.27.5 “command generation error protection” will be generated.

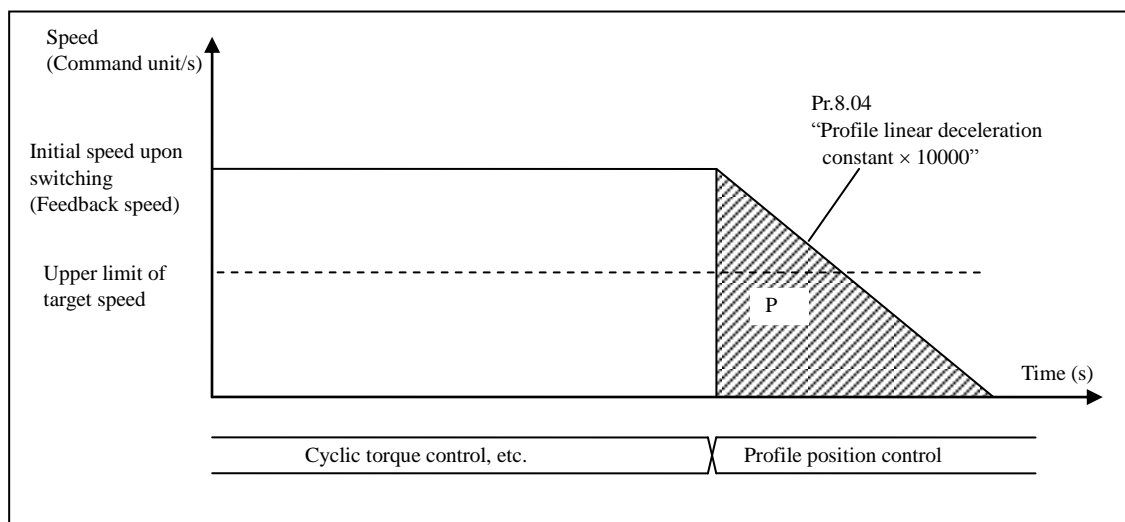

7-6 Control mode switching

7-6-1 Control mode switching method

- When cyclic command change is received, the control mode is changed accordingly. MINAS-A6N can response to the new control mode changed during operation. For precautions for mode change during operation, refer to 7-6-2 and for other precautions refer to 7-6-3.
- The non-cyclic command just prior to command mode change must be “Normal command (□0h)”, and be sure to change the control mode while “Non-cyclic command” is not being executed (Busy = 0). If the control mode is changed while non-cyclic command is being executed (Busy = 1), Err91.1 “RTEX command error protection” and command error (002Eh) will occur.

Example: During operation in CV (cyclic velocity control), mode is changed to PP (profile positioning)

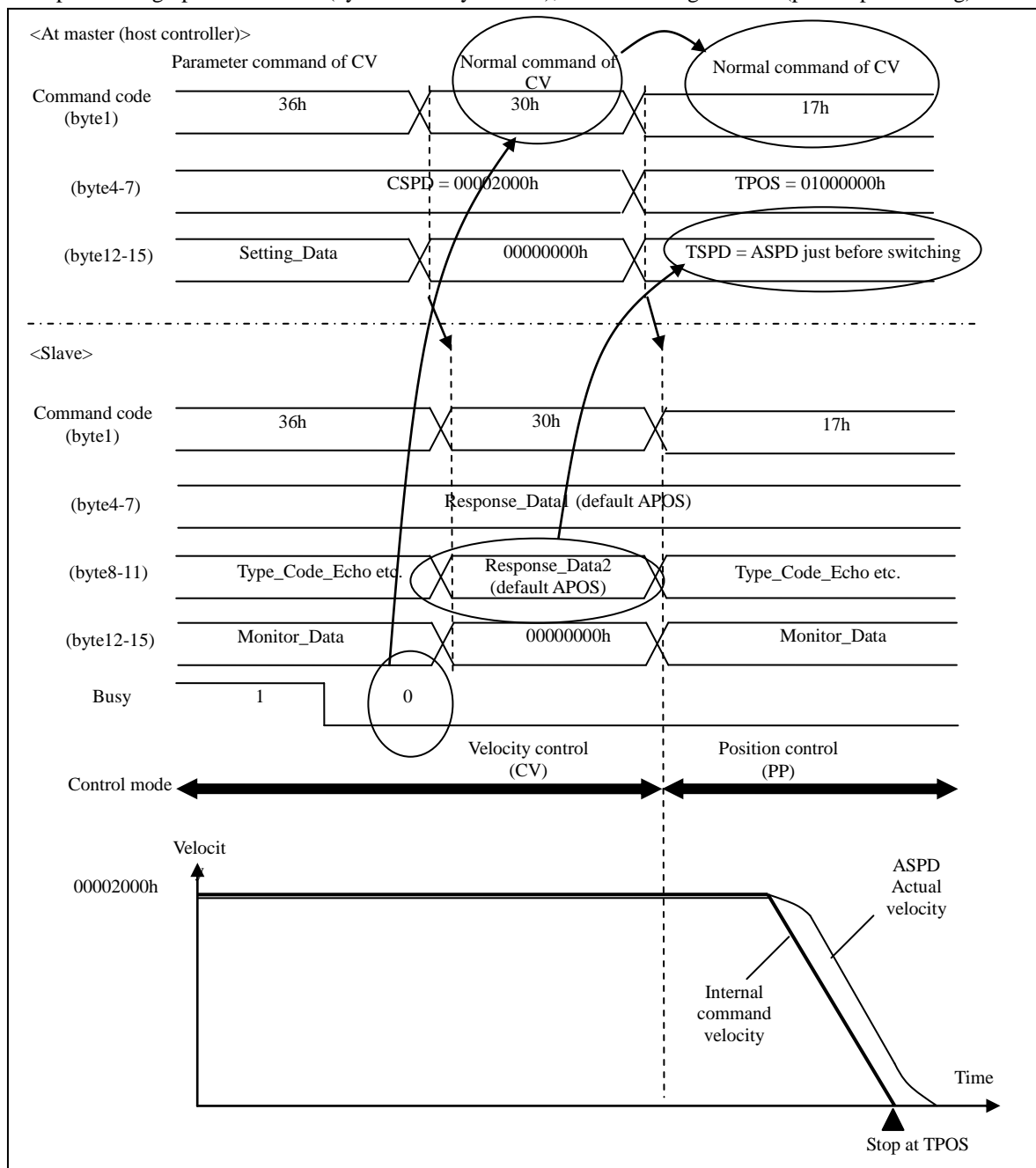

7-6-2 Precautions for control mode change during operation

- Switching between modes PP (profile position control), CV (cyclic velocity control) and CT (cyclic torque control) during operation is possible.
- Upon switching to PP during operation, the profile operation should be started: change to 17h and not to 10h.
- Switching from CP (cyclic position control) to PP, CV or CT is possible during operation. In contrast, switching to CP is possible while operation is paused.
To smoothly change control mode to CP, when applying the command from the host controller, command position (TPOS) should include correction process.
When changing from PP to CP, control mode remains position control, but correction is required to command position (TPOS) of given command.

Supported switching during operation

After switching Before switching	PP (17h)	CP (2□h)	CV (3□h)	CT (4□h)
PP(10h)		×	○	○
CP(20h)	○		○	○
CV(30h)	○	×		○
CT(40h)	○	×	○	

- Do not change control mode during the following PP operation.
Otherwise, Err91.1 (RTEX command error protection) and command error (002Eh) will occur.

Type_Code	Operation mode
12h	Profile position latch absolute positioning
13h	Profile position latch relative positioning
31h	Profile homing 1
32h	Profile homing 2
33h	Profile homing 3
34h	Profile homing 4
36h	Profile homing 6

- When changing control mode during operation, correctly apply the command so that the velocity in the previous and new modes are the same.

Actual velocity (APOS) before mode change = command velocity (target velocity) after mode change
--

When control mode is changed during acceleration/deceleration, mode may not be smoothly changed. Even at the constant velocity, mode may not be smoothly changed due to certain factor, e.g. if acceleration/deceleration setting is large.

- Before changing mode from CV or CT to PP with position command filter (FIR, smoothing) enabled, a steady constant velocity should have been maintained for a period longer than the filter time constant (FIR, smoothing total setting time).
- For smooth switching between control modes, disable the damping filter because the damping filter is active only for position control.
- When the gain changes after switching of control mode, switching is not smoothly performed.

<u>There are some other conditions</u> that prevent smooth switching operation.

If the vibration during switching cause problem, perform switching while related sections are in stop condition.
--

7-6-3 Other precautions related to control mode switching

- After servo-off (including alarm state), counter clear or deceleration and stop according to drive inhibit input, the control mode in the servo driver is forced to change to PP and internal position command generation process is forced to stop.

For example, if the main power is turned off in CV status, servo is turned off and internal status is switched to PP. Result: status and monitor data that rely on control mode will be switched to position control instead of velocity control.

- The control mode is forced to switch inside the driver depending on its operating status irrespective of the command from the host device. This operation has an effect on input/output signal processing. Basically to one terminal assign the whole mode same function.

[Conditions for the control mode to be forced to switch inside the driver]

- When frequency characteristic is analyzed by Setup support software.
(Position loop characteristics is position control, the speed closed loop characteristic and torque speed (vertical) are velocity control, torque speed (normal) is torque control.)
 - During test run operation of Setup support software PANATERM (The mode will be forced to switch to position control.)
 - There is the statement "Forcibly controls the position" in Operating setting of various sequence (Technical Reference Functional Specification "Section 6-3").
 - During retreat operation (position control is enabled by force.)
- When command is NOP (0□h), or if cyclic command is not correctly received due to command error or communication error, the previous command mode will be maintained. Note that commands (command velocity etc.) to servo driver will not be disabled. For NOP command, refer to 7-1-2, for command error, refer to 6-10, and for communication error, refer to 6-11.
 - Only position control is supported under full-closed control and switching to CV or CT will not be possible. Err91.1 "RTEX command error protection" and command error (002Eh) will occur in case CV or CT is received under full-closed control.
 - When communication cycle is 0.0625 ms or 0.125 ms, generation of response data (e.g. position deviation) depending on control mode will delay. For details, refer to 3-1-1 to 3-1-3.
 - For communication cycle/command update cycle, 16-byte mode/32-byte mode and combination of compatible control modes, refer to 2-5-1. If unsupported combination is selected, it will cause Err91.1 "RTEX command error protection" and command error (002Eh).
 - Make sure to perform switching of control mode (cyclic command) or transmitting of NOP (00h) while allowing an interval of 2 ms or longer.
Err91.1 "RTEX command error" and command error (002Eh) occur if the control mode change is made consecutively within a period shorter than 2 ms or if NOP (00h) is transmitted within 2 ms.
 - When homing command (□4h) except for latch mode is being executed, do not change control mode. Before changing control mode, be sure to perform homing process and select the normal command (□0h). Follow the basic switching method described above.
 - Torwue control mode doesn't support when Two-degree-of-freedom control (standard) mode is selected. therefore, Switching function to CT is not available.
When CT is received under Two-degree-of-freedom control (standard) mode, Err91.1 "RTEX command error protection" or command error "002Eh" shall be generated.
 - Only position control is supported under two degree-of-freedom control (synchronous) mode and switching to CV or CT will not be possible.
Err91.1 "RTEX command error protection" and command error (002Eh) will occur in case CV or CT is received under two degree-of-freedom control (synchronous) mode.

7-7 Feedforward function

The host controller can transmit high resolution velocity feedforward (VFF) and torque feedforward (TFF).

7-7-1 Feedforward function validation parameter and command area to be used

■ Main command: Common to 16-byte and 32-byte modes

Byte	bit7	bit6	bit5	bit4	bit3	bit2	bit1	bit0
0	C/R	Update_Counter		MAC-ID				
1	TMG_CNT	Command_Code						
2-3	Control_Bits							
4-7	Command_Data1							
8-11	Command_Data2							
12-15	Command_Data3							

Class	No.	Attribute	Parameter title	Setup range	Unit	Description
7	35	C	RTEX command setting 1	0-2	-	Set up non-cyclic command Command_Data3. 0: Disable 1: Velocity feedforward (Command unit/s) or r/min 2: Torque feedforward (0.1%)

Note: For non-cyclic command that uses Command_Data3 area as Setting_Data, disable is selected because feedforward data cannot be transmitted (see table below), previously received value is used for operation. If this operation causes problem, use Sub_Command_Data2/3 in 32-byte mode area shown on the next page.

When Pr.7.35 = 0 (Disable feedforward), use Command_Data3 area as Setting_Data, and set value to 0 when non-cyclic command is not used (see the table below). When setup is not 0, Command error (0032h) will be returned.

Non-cyclic command	Type_Code	FF transmission Enable/disable	Command_Data3				
			Pr7.35 = 0	Pr7.35 = 1	Pr7.35 = 2		
Normal	0h	All	-	○	FF Disable (set it as 0)	Velocity FF	Torque FF
Reset	1h	All	-	○	FF Disable (set it as 0)	Velocity FF	Torque FF
System ID	2h	All	-	○	FF Disable (set it as 0)	Velocity FF	Torque FF
Homing	4h	021h/022h	Actual position/command position set	×	Setting_Data (setting position)	Setting_Data (setting position)	Setting_Data (setting position)
		Others	-	○	FF Disable (set it as 0)	Velocity FF	Torque FF
Alarm	5h	All	-	○	FF Disable (set it as 0)	Velocity FF	Torque FF
Parameter	6h	011h	Parameter writing	×	Setting_Data (parameter value)	Setting_Data (parameter value)	Setting_Data (parameter value)
		Others	-	○	FF Disable (set it as 0)	Velocity FF	Torque FF
Profile	7h	All	-	×	Setting_Data (target velocity)	Setting_Data (target velocity)	Setting_Data (target velocity)
Monitor	Ah	All	-	○	FF Disable (set it as 0)	Velocity FF	Torque FF

■ Subcommand: Only for 32-byte mode

Byte	bit7	bit6	bit5	bit4	bit3	bit2	bit1	bit0
16	Sub_Chk	0	0	0	Sub_Command_Code			
17	Sub_Type_Code							
18-19	Sub_Index							
20-23	Sub_Command_Data1							
24-27	Sub_Command_Data2							
28-31	Sub_Command_Data3							

Class	No.	Attribute	parameter Title	Setup range	Unit	Description
7	36	C	RTEX command setting 2	0-2	-	Set subcommand, Sub_Command_Data2. 0: Disable 1: Velocity feedforward (Command unit/s) or (r/min) 2: Torque feedforward (0.1%)
7	37	C	RTEX command setting 3	0-2	-	Set subcommand, Sub_Command_Data3. 0: Disable 1: Velocity feedforward (Command unit/s) or (r/min) 2: Torque feedforward (0.1%)

7-7-2 Setting unit and setting range

	Description						
Velocity feedforward (VFF)	<p>After converting the unit, add the value to velocity feedforward value calculated by Pr.1.10 and Pr.1.11, within the range up to motor maximum speed.</p> <p>[Size]: Signed 32-bit [Unit]: Set according to Pr.7.25 “RTEX speed unit setup”.</p> <table border="1"> <thead> <tr> <th>Pr.7.25</th> <th>Unit</th> </tr> </thead> <tbody> <tr> <td>0</td> <td>[r/min]</td> </tr> <tr> <td>1</td> <td>[command unit/s]</td> </tr> </tbody> </table> <p>[Setting range] : - motor max. velocity to + motor max. velocity</p>	Pr.7.25	Unit	0	[r/min]	1	[command unit/s]
Pr.7.25	Unit						
0	[r/min]						
1	[command unit/s]						
Torque feedforward (TFF)	<p>After converting the unit, add the value to torque feedforward value calculated according to Pr.1.12 and Pr.1.13, within the range up to motor maximum torque.</p> <p>[Size]: Signed 32-bit [Unit] : 0.1% [Setting range]: - motor max. torque to + motor max. torque</p>						

7-7-3 Compatible control mode

The feedforward functions are compatible with the following control modes.

For block diagrams of these control modes, refer to Technical Reference Functional Specification “Section 5-2”.

	Position control (CP)	Position control (PP)	Velocity control (CV)	Torque control (CT)
Velocity feedforward (VFF)	Valid ○	Invalid ×	Invalid ×	Invalid ×
Torque feedforward (TFF)	Valid ○	Valid ○	Valid ○	Invalid ×

7-7-4 Other precautions related to feedforward function

- If multiple feedforward functions are set in 32-byte mode, Err93.5 “Parameter setting error protection 4” will occur. This error will not occur in 16-byte mode.
- When invalidating feedforward through the parameter, set the command area to 0. Otherwise, command error (0032h) will occur.
- During servo-lock after completion of homing, feedforward remains valid. When this state causes problem, keep feedforward value at 0 during cyclic homing sequence.
- During deceleration and stop process with servo-off, counter clear or drive inhibit input (POT/NOT), feedforward is at 0.
- When feedforward value in drive inhibit direction is set after deceleration and stop process triggered by drive inhibit input (POT/NOT), command error (0046h) will occur and feedforward value is set to 0.
- When setting value is outside the range, command error (0034h) will occur and previous normal value is held.
- When the value set during switching of control mode is outside the range, command error (0034h) will also occur and the previous normal value will be maintained. If the feedforward in the control mode before switching is invalid, the value is 0.
- In control mode with invalid feedforward, the feedforward value is 0.
- During deceleration with drive inhibit input, torque feedforward is at 0.

8. RTEX Communication Related Protective Function and Troubleshooting

8-1 RTEX communication related protective function

Alarm code (Decimal)		Designation	Attribute			[COM] display
Main	Sub		History memory	Can be cleared	Immediate stop	
80	3	PLL incomplete error protection	○	○	-	Blinks in red
82	0	RTEX node addressing error protection	○	-	-	Lights in red
83	0	RTEX continuous communication error protection 1	○	○	○	Blinks in red
	1	RTEX continuous communication error protection 2	○	○	○	Blinks in red
84	0	RTEX time out error protection	○	○	○	Blinks in red
	3	RTEX synchronization error protection	○	-	-	Lights in red
	5	RTEX communication cycle error protection	○	○	○	Blinks in red
86	0	RTEX cyclic data error protection 1	○	○	○	Blinks in red
	1	RTEX cyclic data error protection 2	○	○	○	Blinks in red
	2	RTEX UpdateCounter error protection	○	-	○	Lights in red
90	2	RTEX interaxis sync establishment error protection	○	-	-	Lights in red
91	1	RTEX command error protection	○	○	-	Blinks in red
	3	RTEX command error protection 2	○	○	-	Blinks in red
98	1	RTEX hardware error protection 1	○	-	-	Lights in red
	2	RTEX hardware error protection 2	○	-	-	Lights in red
	3	RTEX hardware error protection 3	○	-	-	Lights in red

8-1-1 PLL incomplete error protection (Err80.3)

This happens when the communication and the server cannot be synchronized normally.

Cause	<ul style="list-style-type: none"> Phase lock between communication and servo (PLL lock) could not be completed even after 1s of starting synchronization process.
Detecting timing	<ul style="list-style-type: none"> When RTEX communication IC status is RUNNING. During processing execution of establishing communication synchronization
Internal process upon detecting error	<ul style="list-style-type: none"> RTEX communication is not established (Stopped due to synchronization error) If an alarm is detected, RTEX communication IC state changes to INITIAL state.
Action	<ul style="list-style-type: none"> Check that communication cycle set in Pr7.20 "RTEX communication cycle setup" and Pr7.91 "RTEX communication cycle enhancement setting" match the transmission cycle from the host unit. Check that the synchronization mode among multiple axis in Pr7.22 "RTEX function extended setup 1" bit1 matches the setting of the host unit. Check that there are no problems in the processing of the host side units. Check that there are no abnormalities in the transmission cycle of RTEX communication data from the host unit. Design the accuracy of RTEX communication data transmission cycle from the host device within $\pm 0.05\%$. If the communication cycle is 250 us or less, Update_Counter must be varied correctly even when the command update cycle equals the communicate cycle. Please check if there is a problem in Update_Counter. Shut down and reclose the power supply. It may be a failure if indication continues to be displayed and error persists. Terminate use and replace the motor and the servo amplifier. Return to the supplier store for investigation (repairs).
Alarm clear attribute	<ul style="list-style-type: none"> Can be cleared.
Display on COM LED	<ul style="list-style-type: none"> Blinks in red

8-1-2 RTEX node address setting error protection (Err82.0)

This alarm will occur when the value set on the node address setting rotary switch on the servo driver is outside the setting range.

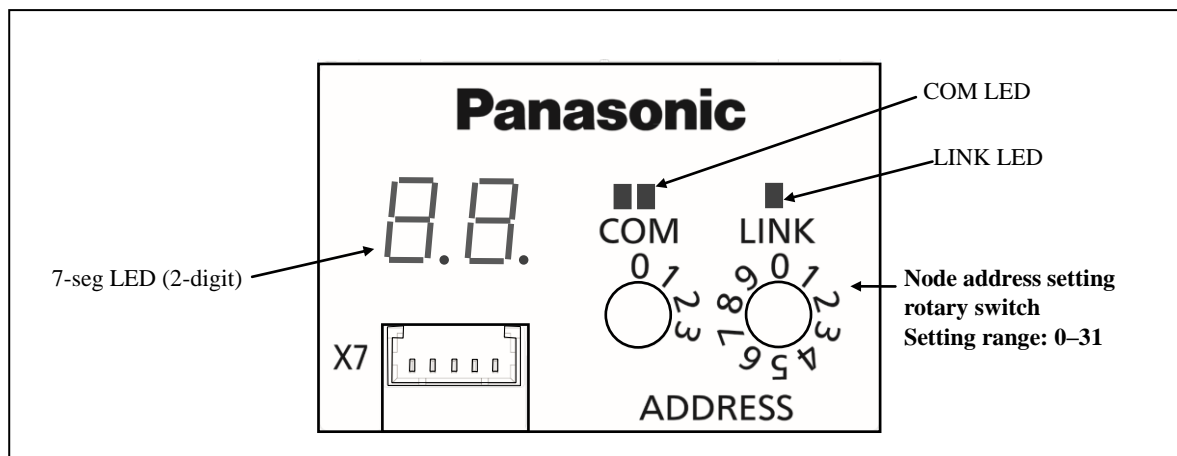

Cause	<ul style="list-style-type: none"> The value set on the rotary switch is outside of 0 to 31.
Detecting timing	<ul style="list-style-type: none"> Upon power up of servo driver control power supply Upon restarting by the reset command
Internal process upon detecting error	<ul style="list-style-type: none"> RTEX communication is not established (aborted due to incomplete initialization) RTEX communication IC state is kept INITIAL (transition).
Action	<ul style="list-style-type: none"> Check the value set on the node address setting rotary switch. When necessary, correct the setting value (0-31), and turn on the servo driver control power. Replace the servo driver as necessary.
Alarm clear attribute	<ul style="list-style-type: none"> Cannot be cleared.
Display on COM LED	<ul style="list-style-type: none"> Lighting in red

8-1-3 RTEX continuous communication error protection 1 (Err83.0)

This alarm will occur when reading error (CRC error) of the data delivered to the local node persists for the predetermined period.

Cause	<ul style="list-style-type: none"> • Reading error (CRC error) of the data delivered to the local node persists for the number of times set for Pr7.95 “Number of RTEX continuous communication error protection 1 detections”.
Detecting timing	<ul style="list-style-type: none"> • When RTEX communication IC status is RUNNING. • When received data is read at the communication cycle.
Internal process upon detecting error	<ul style="list-style-type: none"> • Discard the received data. • Use the previously received normal data for processing (servo is in alarm status). • Return Byte 1 of response as FFh. • RTEX communication IC keeps RUNNING status. <ul style="list-style-type: none"> ▪ Because the communication continues, if the normal reception is possible after occurrence of alarm, commands such as alarm clear can be received.
Action	<ul style="list-style-type: none"> • Check the communication cable for excessive noises. • Check the communication cable for length, layout arrangement, and connections. • Check that the communication cable is category 5-e or better shielded twisted pair cable (STPC) specified by TIA/EIA-568. • Replace the cable with a new one as necessary. • Attach the ferrite core to the communication cable. • Replace the servo driver as necessary. • Increase the value set for Pr7.95.
Alarm clear attribute	<ul style="list-style-type: none"> • Can be cleared.
Display on COM LED	<ul style="list-style-type: none"> • Blinks in red

8-1-4 RTEX continuous communication error protection 2 (Err83.1)

This alarm will occur when reading error of the data delivered to the local node persists for the predetermined period. This alarm indicates that CRC error, missing reception or cyclic error of the data delivered to the local node has occurred.

If these errors occur alternatively, they are distinguished by the alarm.

Cause	<ul style="list-style-type: none"> • Reading error (CRC error, missing reception or cyclic error) of the number of times set for Pr7.96 “Number of RTEX continuous communication error protection 2 detections”.
Detecting timing	<ul style="list-style-type: none"> • When RTEX communication IC status is RUNNING. • When received data is read at the communication cycle. <ul style="list-style-type: none"> ▪ Missing reception will be detected only when sync is established.
Internal process upon detecting error	<ul style="list-style-type: none"> • Discard the received data. • Use the previously received normal data for processing (servo is in alarm status). • Return Byte 1 of response as FFh. • RTEX communication IC keeps RUNNING status. <ul style="list-style-type: none"> ▪ Because the communication continues, if the normal reception is possible after occurrence of alarm, commands such as alarm clear can be received.
Action	<ul style="list-style-type: none"> • Check the communication cable for excessive noises. • Check the communication cable for length, layout arrangement, and connections. • Check that the communication cable is category 5-e or better shielded twisted pair cable (STPC) specified by TIA/EIA-568. • Replace the cable with a new one as necessary. • Attach the ferrite core to the communication cable. • Replace the servo driver as necessary. • Increase the value set for Pr7.96.
Alarm clear attribute	<ul style="list-style-type: none"> • Can be cleared.
Display on COM LED	<ul style="list-style-type: none"> • Blinks in red

8-1-5 RTEX time out error protection (Err84.0)

This alarm will occur when communication data has not been received, and RTEX communication IC has not output the reception interrupt (missing reception) process start signal for predetermined period.

Cause	<ul style="list-style-type: none"> • Communication data has not been received, and RTEX communication IC has not output the reception interrupt (missing reception) process start signal for the number of times set for Pr7.97 “Number of RTEX communication timeout error protection detections”.
Detecting timing	<ul style="list-style-type: none"> • When RTEX communication IC status is RUNNING. • When synchronization between the communication and servo is established. • When received data is read at the communication cycle.
Internal process upon detecting error	<ul style="list-style-type: none"> • Use the previously received data for processing until an alarm is detected. • If an alarm is detected, RTEX communication IC state changes to INITIAL state. • Synchronization established between communication and servo is changed to asynchronous state. <ul style="list-style-type: none"> ▪ The communication blackout occurs so that the host controller should reestablish the communication.
Action	<ul style="list-style-type: none"> • Check the communication cable for disconnection. • Check the preceding stage node whether it is ready for transmission. <ul style="list-style-type: none"> ▪ For checking procedure, refer to Section 8-3. • Check the RTEX communication data transmission cycle of the host controller. • Check to see that the communication cycle set by Pr7.20 “RTEX communication cycle setup” and Pr7.91 “RTEX communication cycle expansion setting” matches the transmission cycle of the host controller. • Check the communication cable for excessive noises. • Check the communication cable for length, layout arrangement, and connections. • Check that the communication cable is category 5-e or better shielded twisted pair cable (STPC) specified by TIA/EIA-568. • Replace the cable with a new one as necessary. • Attach the ferrite core to the communication cable. • Replace the servo driver as necessary. • Increase the value set for Pr7.97.
Alarm clear attribute	<ul style="list-style-type: none"> • Can be cleared.
Display on COM LED	<ul style="list-style-type: none"> • Blinks in red

8-1-6 RTEX synchronization error protection (Err84.3)

This alarm occurs when abnormal condition is detected during synchronization between the servo amplifier and communication.

Cause	<ul style="list-style-type: none"> Generated abnormal communication during synchronization between the servo amplifier and communication.
Detecting timing	<ul style="list-style-type: none"> When RTEX communication IC status is RUNNING. When synchronization between the communication and servo is established. During processing execution of establishing communication synchronization
Internal process upon detecting error	<p>During processing execution of establishing communication synchronization</p> <ul style="list-style-type: none"> RTEX communication is not established (aborted due to incomplete initialization) RTEX communication IC state is kept INITIAL (transition). <p>When synchronization between the communication and servo is established</p> <ul style="list-style-type: none"> Use the previously received data for processing until an alarm is detected. If an alarm is detected, RTEX communication IC state changes to INITIAL state. Synchronization established between communication and servo is changed to asynchronous state.
Action	<ul style="list-style-type: none"> Replace the servo driver if the cause is not removed after turning on control power.
Alarm clear attribute	<ul style="list-style-type: none"> Cannot be cleared.
Display on COM LED	<ul style="list-style-type: none"> Lighting in red

8-1-7 RTEX communication cycle error protection (Err84.5)

This alarm occurs when the receive interrupt process start signal is output from RTEX communication IC at an irregular frequency, causing out of synchronization between communication and servo.

Cause	<ul style="list-style-type: none"> • The receive interrupt process start signal output from RTEX communication IC at an irregular cycle causes out-of-synchronization between communication and servo.
Detecting timing	<ul style="list-style-type: none"> • When RTEX communication IC status is RUNNING. • When synchronization between the communication and servo is established. • Output of receive interrupt process start signal
Internal process upon detecting error	<ul style="list-style-type: none"> • Use the previously received data for processing until an alarm is detected. • If an alarm is detected, RTEX communication IC state changes to INITIAL state. • Synchronization established between communication and servo is changed to asynchronous state. <ul style="list-style-type: none"> ▪ The communication blackout occurs so that the host controller should reestablish the communication.
Action	<ul style="list-style-type: none"> • Check the RTEX communication data transmission cycle of the host controller. • Check to see that the communication cycle set by Pr7.20 “RTEX communication cycle setup” and Pr7.91 “RTEX communication cycle expansion setting” matches the transmission cycle of the host controller. • Check the communication cable for excessive noises. • Check the communication cable for length, layout arrangement, and connections. • Check that the communication cable is category 5-e or better shielded twisted pair cable (STPC) specified by TIA/EIA-568. • Replace the cable with a new one as necessary. • Attach the ferrite core to the communication cable. • Replace the servo driver as necessary.
Alarm clear attribute	<ul style="list-style-type: none"> • Can be cleared.
Display on COM LED	<ul style="list-style-type: none"> • Blinks in red

8-1-8 RTEX cyclic data error protection 1/2 (Err86.0/Err86.1)

This alarm will occur, when data error in cyclic command area (C/R, MAC_ID, cyclic command) occurs or when Sub_Chk error continues in 32-byte mode for the predetermined period.

Cause	<ul style="list-style-type: none"> Data error occurs in cyclic command area (C/R, MAC_ID, cyclic command) or Sub_Chk error continues in 32-byte mode for the number of times set for Pr7.98 “Number of RTEX cyclic data error protection 1/2 detections”. 			
	Alarm code	Detected space		Cause
	Err. 86.0	Byte 0. bit 4–0	MAC-ID	Not fit with setting on rotary switch
		Byte 0. bit 7	C/R	Set at 1
Byte 16. bit 7		Sub_Chk	Set at 0	
Err86.1	Byte 1. bit 6–4	Cyclic command	Undefined	
Detecting timing	<ul style="list-style-type: none"> When RTEX communication IC status is RUNNING. When synchronization between the communication and servo is established. When received data is read at the communication cycle. 			
Internal process upon detecting error	<ul style="list-style-type: none"> Command error occurs while in alarm condition. 			
	Alarm code	Detected space		Error_Code
	Err86.0	Byte 0. bit 4–0	MAC-ID	0011h
		Byte 0. bit 7	C/R	0012h
Byte 16. bit 7		Sub_Chk		
Err86.1	Byte 1. bit 6–4	Cyclic command	0021h	
<ul style="list-style-type: none"> For details of command error, see Section 6-9-1. Discard the received data. Use the previously received normal data for processing (servo is in alarm status). RTEX communication IC keeps RUNNING status. <ul style="list-style-type: none"> Because the communication continues, if the normal reception is possible after occurrence of alarm, commands such as alarm clear can be received. 				
Action	<ul style="list-style-type: none"> Check the data in the cyclic command field (Detected space in the table above). Check the process in the host controller Increase the value set for Pr7.98. 			
Alarm clear attribute	<ul style="list-style-type: none"> Can be cleared. 			
Display on COM LED	<ul style="list-style-type: none"> Blinks in red 			

8-1-9 RTEX_Update_Counter error protection (Err86.2)

This alarm will occur when Update_Counter is not renewed correctly because errors have been accumulated more than set number for Pr7.38 "RTEX_Update_Counter error protection setup".

When Pr7.38 is 0 or 1, this alarm is invalid.

This alarm is to detect conflict in command renewal cycle between an upper device and the driver. Be careful, detection may not be performed correctly if the communication cycles are not synchronized.

Cause	<ul style="list-style-type: none"> Update_Counter is not renewed correctly because errors have been accumulated more than set number for Pr7.38 "RTEX_Update_Counter error protection setup".
Detecting timing	<ul style="list-style-type: none"> RTEX communication IC is in RUNNING state. Sync establishment between communication and servo is in transient condition. At reading received data of each command renewal cycle.
Internal process upon detecting error	<ul style="list-style-type: none"> Received data are taken as they are. RTEX communication IC state keeps RUNNING state. Sync establishment condition between communication and servo is continued.
Action	<ul style="list-style-type: none"> Check if there is any problem in frequency setting in upper device side and in driver side. When Update_Counter is not used with ratio of communication frequency and command renewal frequency being 1 : 1, this alarm is made invalid.
Alarm clear attribute	<ul style="list-style-type: none"> Can not be cleared.
Display on COM LED	<ul style="list-style-type: none"> Lights in red

8-1-10 RTEX interaxis sync establishment error protection (Err90.2)

This alarm will occur when communication error occurs in the full-sync mode and in sync establishment transient condition or when the communication is interrupted.

Cause	<ul style="list-style-type: none"> • Communication error occurs in full-sync mode and in sync establishment transient condition or the communication is interrupted.
Detecting timing	<ul style="list-style-type: none"> • RTEX communication IC is in RUNNING state. • Sync establishment between communication and servo is in transient condition.
Internal process upon detecting error	<ul style="list-style-type: none"> • After detection of alarm, RTEX communication IC shifts to INITIAL state. • Sync establishment condition between communication and servo is undefined.
Action	<ul style="list-style-type: none"> • Take the same measures as for Err83.0 or Err84.0.
Alarm clear attribute	<ul style="list-style-type: none"> • Can not be cleared.
Display on COM LED	<ul style="list-style-type: none"> • Lights in red

8-1-11 RTEX command error protection (Err91.1)

This error will occur when the cyclic command (Byte 1, bits 6–4) is defined but not correctly received.

Cause	<ul style="list-style-type: none"> • Mismatched combination of communication cycle, semi-closed/full-closed(including virtual full-closed control mode), 16/32-byte mode and control mode. • The control mode switching interval is shorter than 2 ms. • Control mode is switched during profile position latch positioning/profile homing operation (Type_Code = 12h, 13h, 31h, 32h, 33h, 34h, 36h). • Control mode is switched during processing of non-cyclic command (Busy = 1). • During operation of profile position latch positioning/profile homing (Type_Code = 12h, 13h, 31h, 32h, 33h, 34h, 36h), the homing command (□4h) is executed. • During operation of profile positioning/profile continuous movement (Type_Code = 10h, 11h, 20h), the initialization mode (Type_Code = 1□h, 31h) of the homing command (□4h) is executed. • During operation with profile position control (PP), Type_Code is changed. • Run the home return command (□4h) Type_Code=1□h/2□h during the velocity control (CV)/torque control (CT) • During Two-degrees-of-freedom Mode control (standard), Control mode has been changed torque control(CT). <ul style="list-style-type: none"> * This is a specification for function extended version 4 and earlier. • During Two-degrees-of-freedom control (synchronous) Mode, Control mode has been changed to velocity control (CV)/torque control (CT).
Detecting timing	<ul style="list-style-type: none"> • When RTEX communication IC status is RUNNING. • When synchronization between the communication and servo is established. • When received data is read at the communication cycle.
Internal process upon detecting error	<ul style="list-style-type: none"> • The command error occurs upon occurrence of the alarm. <ul style="list-style-type: none"> ▪ For details of command error, see Section 6-10-1. • RTEX communication IC keeps RUNNING status.
Action	<ul style="list-style-type: none"> • Check the process of the host controller. <ul style="list-style-type: none"> ▪ When changing to another control mode after selecting the current mode, wait at least for 2 ms. ▪ Check correspondence relation between the executive function and control mode.
Alarm clear attribute	<ul style="list-style-type: none"> • Can be cleared.
Display on COM LED	<ul style="list-style-type: none"> • Blinks in red

8-1-12 RTEX command error protection 2 (Err91.3)

This occurs when a return to origin cancellation phenomenon occurs during return to origin command execution at a timing where it cannot be canceled.

Cause	<ul style="list-style-type: none"> • Latch mode with stop function was canceled by the host device during return operation to the latch position with latch mode with stop function. • One of the following cancellations of return to origin command was executed from the host device during position information initialization process immediately before completion of return to origin. <ul style="list-style-type: none"> • Reception of command code=20h in CP return to origin • Reception of HardStop command in PP return to origin • Reception of SmoothStop command in PP return to origin • One of the following return to origin cancellation phenomena occurred during the return operation immediately after origin detection in PP return to origin. <ul style="list-style-type: none"> • Reception of HardStop command • Reception of SmoothStop command • Reception of servo-off command • Detection of main power supply OFF • Detection of STO • Alarm detection • Detection of both POT and NOT signals • Detection of HOME signal OFF with HOME + Z phase (TypeCode=31h) • Detection of retreat operation start condition
Detecting timing	<ul style="list-style-type: none"> • Period since starting the return operation for latch mode with stop function until Latch_Comp1 becomes 1. • During position information initialization immediately before completion of return to origin • During return operation after origin detection in PP return to origin
Internal process upon detecting error	<ul style="list-style-type: none"> • Cancellation of latch mode with stop function. • Cancellation of return to origin. • RTEX communication IC keeps RUNNING status. <ul style="list-style-type: none"> ▪ Because the communication continues, if the normal reception is possible after occurrence of alarm, commands such as alarm clear can be received. • Sync establishment condition between communication and servo is continued.
Action	<ul style="list-style-type: none"> • Check if cancellation of latch mode with stop function is executed after stopping the motor. • Check if the return to origin command was canceled near the origin signal. (Cancellation after stopping the motor recommended)
Alarm clear attribute	<ul style="list-style-type: none"> • Can be cleared.
Display on COM LED	<ul style="list-style-type: none"> • Blinks in red

8-1-13 RTEX hardware error protection 1/2/3 (Err98.1/Err98.2/Err98.3)

This alarm occurs when an error occurs in RTEX communication circuit.

Cause	<ul style="list-style-type: none"> • An error occurs on RTEX communication circuit.
Detecting timing	<ul style="list-style-type: none"> • On power up of servo driver control power. • Upon restarting by the reset command.
Internal process upon detecting error	<ul style="list-style-type: none"> • RTEX communication cannot be established due to incomplete initialization. • RTEX communication IC status is still in INITIAL condition (transition).
Action	<ul style="list-style-type: none"> • Replace the servo driver if the cause is not removed after turning on control power.
Alarm clear attribute	<ul style="list-style-type: none"> • Cannot be cleared.
Display on COM LED	<ul style="list-style-type: none"> • Lighting in red

8-2 RTEX communication warnings

Warning code (decimal)	Designation
C0h	RTEX continuous communication error warning
C1h	RTEX accumulated communication error warning
C2h	RTEX Update_Counter error warning
D2h	PANATERM command execution warning

8-2-1 RTEX continuous communication error warning (WngC0h)

This warning will occur when the No. of continuously detected reading errors (CRC errors) of the data delivered to the local node reaches the setting value of Pr7.26 “RTEX continuous error warning setup”.

The detecting timing and corrective action are basically the same as those for Err83.0 “RTEX continuous communication error”.

When Pr7.26 is 0 or when bit 9 of Pr6.38 Attribute C is 1, this warning is disabled.

Cause	<ul style="list-style-type: none"> The No. of detected continuous reading errors (CRC errors) of the data delivered to the local node reaches the setting value of Pr7.26 “RTEX continuous error warning setup”.
Detecting timing	<ul style="list-style-type: none"> When RTEX communication IC status is RUNNING. When received data is read at the communication cycle.
Internal process upon detecting error	<ul style="list-style-type: none"> Discard the received data. Use the previously received normal data for processing. Return Byte 1 of response as FFh. RTEX communication IC keeps RUNNING status. Synchronization between communication and servo is kept established. <ul style="list-style-type: none"> Because the communication continues, if the normal reception is possible after occurrence of warning, commands such as alarm clear can be received.
Action	<ul style="list-style-type: none"> Check the communication cable for excessive noises. Check the communication cable for length, layout arrangement, and connections. Check that the communication cable is category 5-e or better shielded twisted pair cable (STPC) specified by TIA/EIA-568. Replace the cable with a new one as necessary. Attach the ferrite core to the communication cable. Replace the servo driver as necessary.
Warning clearing procedure after removal of cause	<ul style="list-style-type: none"> Disable this warning and then execute alarm clear. Execute the power reset or reset command to reboot the system.

8-2-2 RTEX accumulated communication error warning (WngC1h)

This warning will occur when the No. of detected accumulated reading errors (CRC errors) of the data delivered to the local node reaches the setting value of Pr7.27 “RTEX accumulated error warning setup”.

The detecting timing and corrective action are basically the same as those for Err83.0 “RTEX continuous communication error”.

When Pr7.27 is 0 or when bit 10 of Pr6.38 Attribute C is 1, this warning is disabled.

Cause	<ul style="list-style-type: none"> The No. of detected accumulated reading errors (CRC errors) of the data delivered to the local node reaches the setting value of Pr7.27 “RTEX accumulated error warning setup”.
Detecting timing	<ul style="list-style-type: none"> When RTEX communication IC status is RUNNING. When received data is read at the communication cycle.
Internal process upon detecting error	<ul style="list-style-type: none"> Discard the received data. Use the previously received normal data for processing. Return Byte 1 of response as FFh. RTEX communication IC keeps RUNNING status. Synchronization between communication and servo is kept established. <ul style="list-style-type: none"> Because the communication continues, if the normal reception is possible after occurrence of warning, commands such as alarm clear can be received.
Action	<ul style="list-style-type: none"> Check the communication cable for excessive noises. Check the communication cable for length, layout arrangement, and connections. Check that the communication cable is category 5-e or better shielded twisted pair cable (STPC) specified by TIA/EIA-568. Replace the cable with a new one as necessary. Attach the ferrite core to the communication cable. Replace the servo driver as necessary.
Warning clearing procedure after removal of cause	<ul style="list-style-type: none"> Disable this warning and then execute alarm clear. Execute alarm clear command or the power reset or reset command to reboot the system.

8-2-3 RTEX Update_Counter error warning (WngC2h)

This warning will occur when the total No. of updates of Update_Counter does not reach the setting of Pr7.28 "RTEX_Update_Counter error warning setup".

When the setting of Pr7.28 is 0 or 1, or when bit 11 of Pr6.38 Attribute C is 1, this warning is invalid.

This warning indicates that updating cycle of the host controller and that of the servo driver are different with each other. Mismatched communication cycles will cause detection error.

Cause	<ul style="list-style-type: none"> Total number of updates of Update_Counter does not reach the setting of Pr.7.28 "RTEX_Update_Counter error warning setup".
Detecting timing	<ul style="list-style-type: none"> When RTEX communication IC status is RUNNING. When synchronization between the communication and servo is established. When received data is read at the command update cycle.
Internal process upon detecting error	<ul style="list-style-type: none"> Capture the received data as it is. RTEX communication IC keeps RUNNING status. Synchronization between communication and servo is kept established. <ul style="list-style-type: none"> Because the communication continues, if the normal reception is possible after occurrence of warning, commands such as alarm clear can be received.
Action	<ul style="list-style-type: none"> Check to see that the host controller and driver are normally setting cycles. When the communication cycle to command updating cycle ratio is 1:1 and Update_Counter is not used, this warning is disabled.
Warning clearing procedure after removal of cause	<ul style="list-style-type: none"> Disable this warning and execute alarm clear. Execute alarm clear command or the power reset or reset command to reboot the system.

8-2-4 PANATERM command execution warning (WngD2h)

Occurs when operation commands (test run, FFT, Z phase search, fit gain) or pin assign setting (config command) are executed by USB communications (PANATERM) in RTEX communications established state, when Pr7.99 "RTEX function extended setup 6" bit0 is 1.

This warning will not occur when Pr7.99 bit0 is 0.

Cause	<ul style="list-style-type: none"> • Operation command or config. Command was executed by USB communications (PANATERM) while RTEX communication is established.
Detecting timing	<ul style="list-style-type: none"> • When RTEX communication IC status is RUNNING. • When synchronization between the communication and servo is established. • Operation command or config, command by USB communications has been executed in the abovementioned conditions.
Internal process upon detecting error	<ul style="list-style-type: none"> • RTEX communication IC keeps RUNNING status. • Synchronization between communication and servo is kept established. <ul style="list-style-type: none"> ▪ Because the communication continues, if the normal reception is possible after occurrence of warning, commands such as alarm clear can be received.
Action	<ul style="list-style-type: none"> • Suspends operation command by USB communications
Warning clearing procedure after removal of cause	<ul style="list-style-type: none"> • Disable this warning and execute alarm clear. • Execute alarm clear command or the power reset or reset command to reboot the system.

8-3 Locating disconnection point of network cable

With power supplied to all nodes, check the network status LEDs, "LINK". If an LED is not lighting, check the network cable connected to the receiving connector (RX) of the servo driver having the unlit LED.

When checking on/off status of the LED, test the electrical connection regardless of condition and performance of RTEX communication IC.

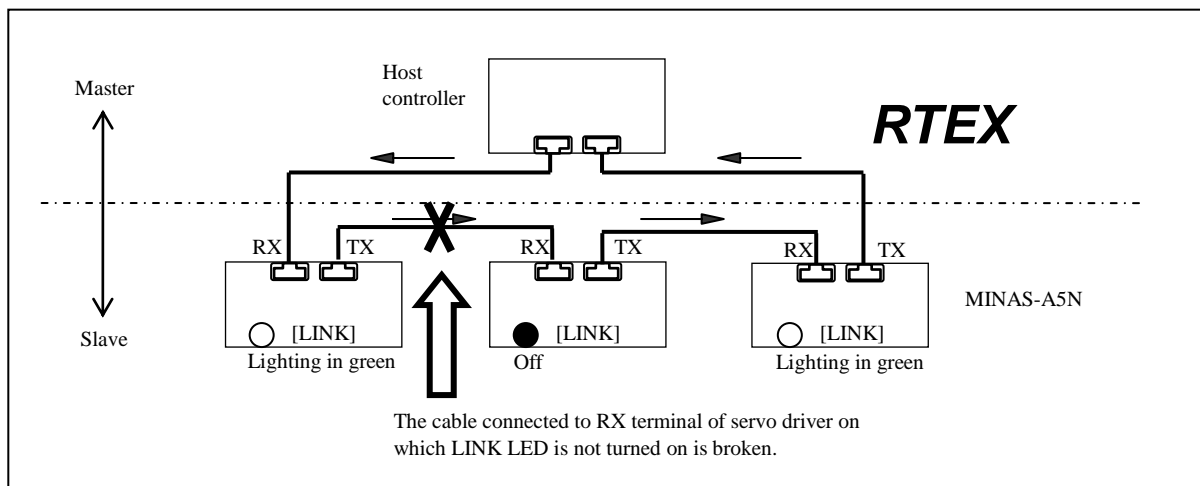
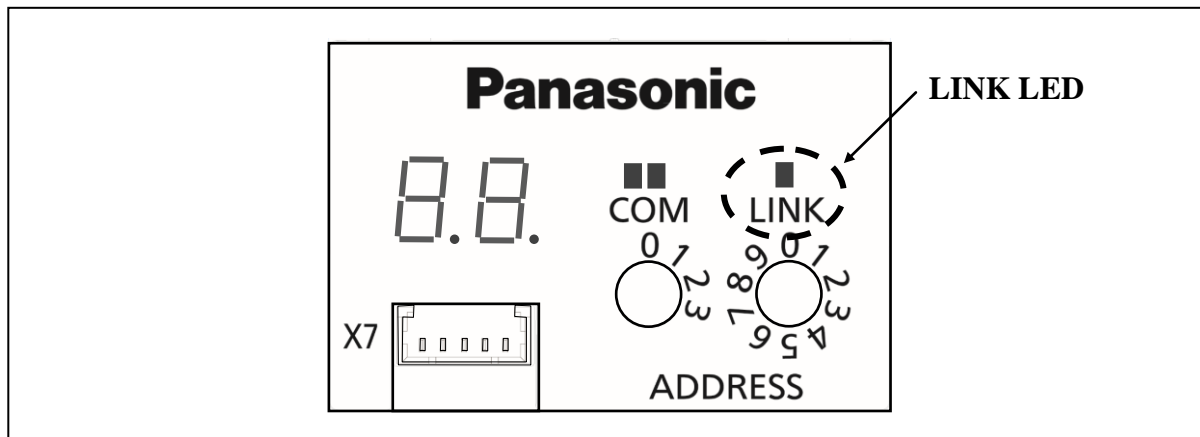

When the network cable connected to the receiving side breaks, Err. 84.0 “RTEX time out error protection” occurs.

When LINK LED that has been lighting in green is turned off, the possible cause is: disconnection or loose connection of cable, or resetting (power shutdown or reset command) of the node connected to the preceding stage.

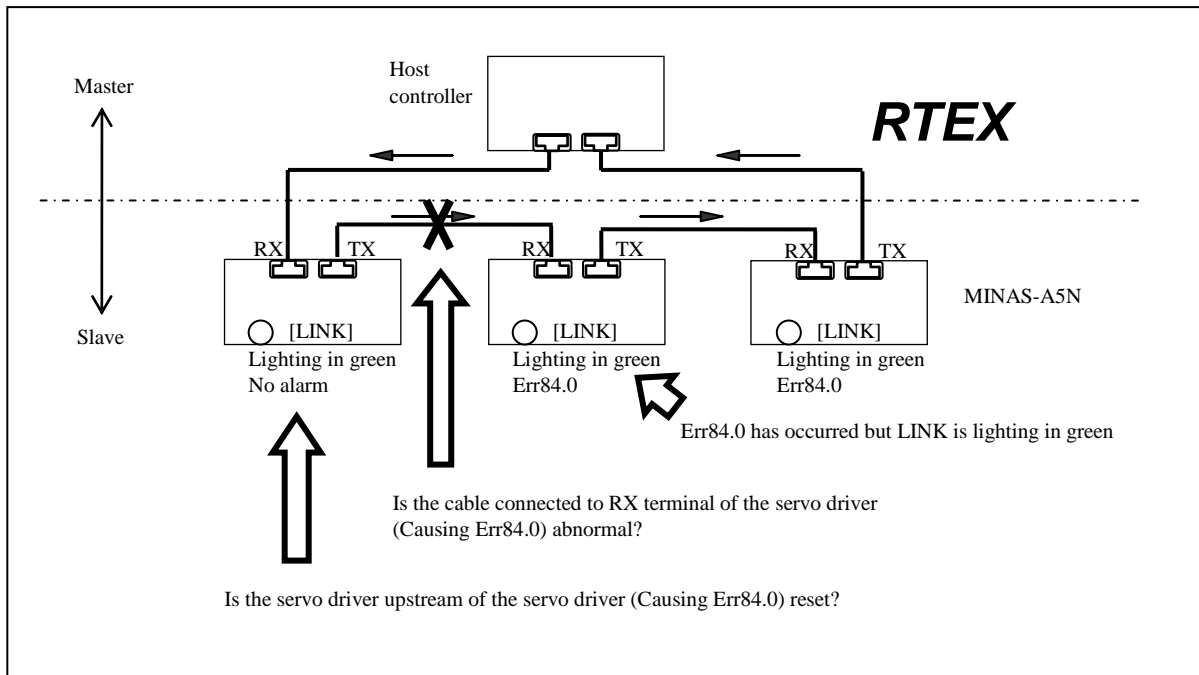

Note: When the master detects time out, send servo off command to all servos without initializing the communication to shut down the servos connected upstream of disconnection point.

If the communication is initialized, all servos will cause Err84.0 “RTEX time out error protection”, making it difficult to locate the disconnected section.