

**ACCURATE BY DESIGN**  
**SENSORS FOR THE**  
**PRINTING INDUSTRY**





Pepperl+Fuchs is a leading developer and manufacturer of electronic sensors and components for the global automation market. We continually set new standards in quality and innovative technology.

## When it comes to speed, reliability and accuracy, Pepperl+Fuchs is your trusted partner.

We offer you the right sensor solution for your prepress, press and postpress machines. Precise miniature sensors ensure the smooth operation of your printing processes. Ultrasonic sensors detect double sheets and splices regardless of the material or color. Misfed sheets in collating, folding and binding machines are also eliminated: Special vision sensors reliably verify sheets by image comparison or code reading.

Our experts help you select the right sensor technology for your specific application. Choose from our single source, wide product range.

With our global presence, reliable service and flexible production facilities, we deliver complete individual solutions for reliable and efficient operation of your systems.

Our experts will be happy to help you.

Telephone: +49 (0) 621 776-4411

Fax: +49 (0) 621 776-27-4411

E-mail: [fa-info@pepperl-fuchs.com](mailto:fa-info@pepperl-fuchs.com)

Internet: [www.pepperl-fuchs.com/print-paper](http://www.pepperl-fuchs.com/print-paper)





<b>SHEET FED PRINTING</b>	<b>4</b>
<b>WEB FED PRINTING</b>	<b>6</b>
<b>DIGITAL PRINTING AND ATMs</b>	<b>8</b>
<b>FOLDING</b>	<b>9</b>
<b>COLLATING</b>	<b>10</b>
<b>STITCHING · BINDING</b>	<b>12</b>
<b>MAILROOM</b>	<b>13</b>
<b>DIE CUTTING</b>	<b>14</b>
<b>STACK TURNERS</b>	<b>15</b>
<b>SHEET VERIFICATION AND CODE READING</b>	<b>16</b>
<b>SHEET DETECTION AND ALIGNMENT</b>	<b>17</b>
<b>SELECTION GUIDE</b>	<b>18</b>
<b>SENSORS FOR THE PRINTING INDUSTRY</b>	<b>19</b>

## STACKER SAFETY

### SAFETY LIGHT CURTAINS SLCS, SLCT, SLP, SafeBox

- Safety light curtains detect entry into hazardous areas
- Safety categories 2 and 4
- Narrow beams provide immunity to interference from reflective surfaces
- SafeBox modular safety controller connects all safety components into one unit

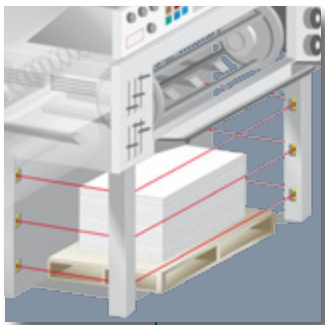

## SHEET COUNTING AT DELIVERY

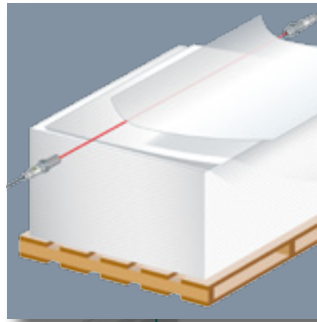

### LASER THRU-BEAM SENSORS E18/EV18-LAS

- High switching accuracy
- Automatic threshold adjustment for safe operation and dust insensitivity
- Eyesafe laser class 1

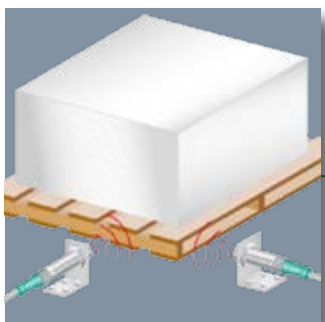
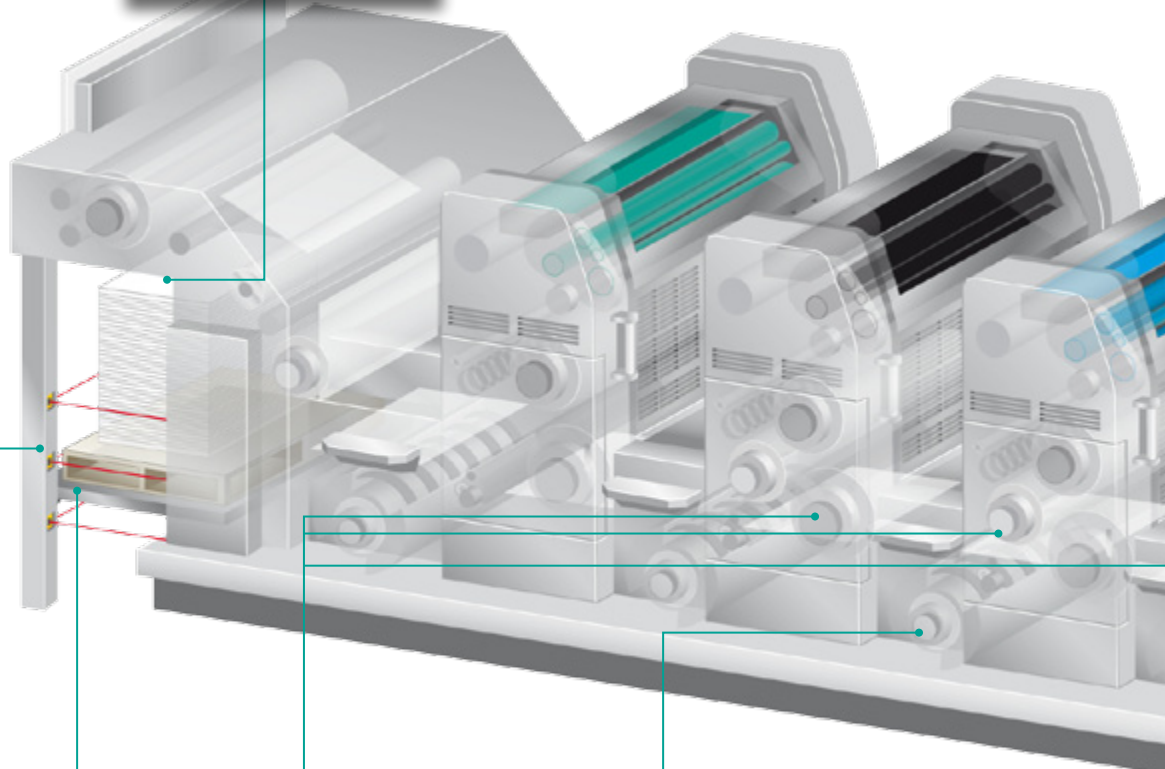

## PALLET DETECTION

### DISTANCE MEASUREMENT UB500-18GM, UB500-F54, UC500-L2, VDM28

- Reliable detection of position regardless of pallet color or finish
- Analog and discrete outputs
- Ultrasonic and photoelectric solutions available

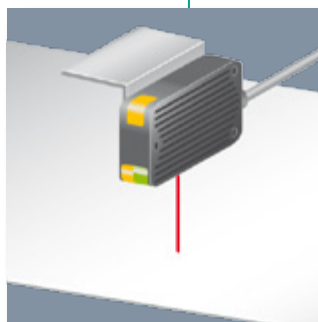

## SHEET PRESENCE

### DIFFUSE MODE SENSORS MLV41, MLV41-8-HV, ML4.2, R2

- Detects media directly while ignoring reflective surfaces close to the target
- Enhanced edge detection using background suppression sensors
- Fast response time

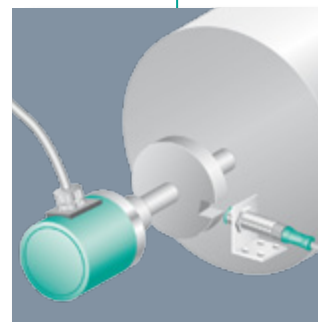

## CYLINDER AND PART POSITION

### INDUCTIVE SENSORS, ENCODERS

- Precise detection of metal gear teeth, notches, and cams
- Reduction factor 1 senses all metals at the same distance
- Wide variety of housings and sensing ranges

## INK LEVEL DETECTION

### ULTRASONIC SENSORS UC300-F43 , UB300-18GM

- Reliable ink level measurement
- Low-level alarm
- Chemically-resistant housings

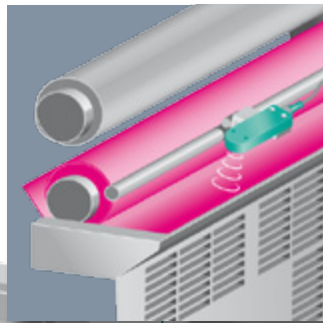

## DOUBLE SHEET DETECTION

### ULTRASONIC SENSORS UDC-18GM

- Identifies zero, one, or multiple (overlapping) sheets
- Fast response time
- Extremely wide range of media, including fine papers, transparencies, cardboard, glossy surfaces, and metal foils

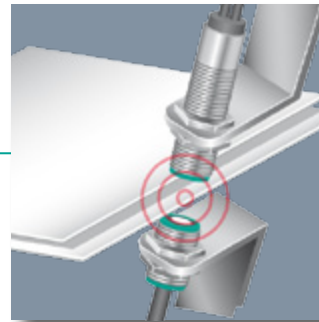

## STACK HEIGHT MONITORING AND ALIGNMENT

### THRU-BEAM AND DIFFUSE MODE SENSORS ML4.2, MLV41, MLV12

- Reliable detection due to small black-to-white difference
- Small, sharp light beam
- 4-in-1 output
- Antistatic lens repels paper dust

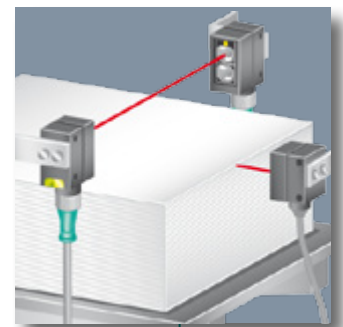

## SHEET ALIGNMENT (FRONT LAY, SIDE LAY)

### DIFFUSE MODE SENSORS ML10, KT10, ML4.2

- Fast and accurate detection of a wide variety of media
- Small black-to-white difference with superior background suppression
- Wide variety of sensor styles for use in tight spaces
- Protected against paper dust and vibration
- 4-in-1 output minimizes inventory

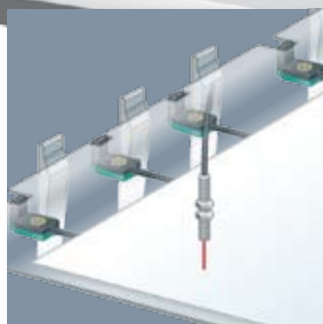

## STACK CENTERING

### ULTRASONIC SENSORS, LASER PONITER UB400-F77, M18...LAS-P

- Proper stack alignment
- Teach-In input
- Small blind range
- Small and miniature housings

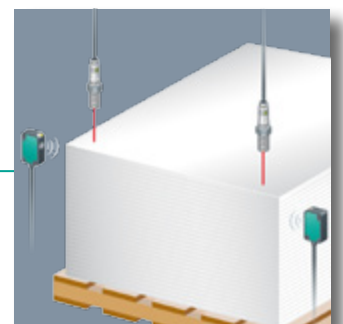

## ROLL EMPTY DETECTION

### DISTANCE MEASUREMENT DEVICES VDM28, RL28, UB500-30GM, UB500-F54

- Monitors web stock diameter
- Sends signal for automatic or manual splicing
- Insensitive to dust and vibrations
- Immune to roll color
- Analog and discrete outputs
- Photoelectric and ultrasonic solutions

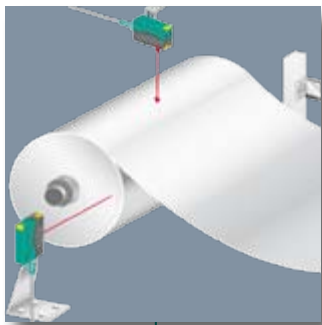

## WEB TENSIONING

### DISTANCE MEASUREMENT DEVICES VDM28, UB500-F54

- Ensures consistent web tension
- Consistent end of roll/splice detection
- Unaffected by paper dust
- Versatile mounting
- Solutions include photoelectric or ultrasonic sensors

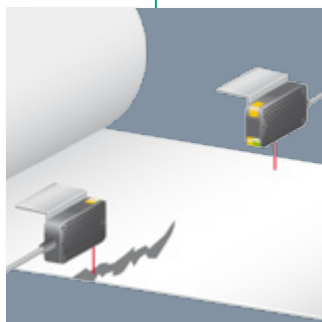
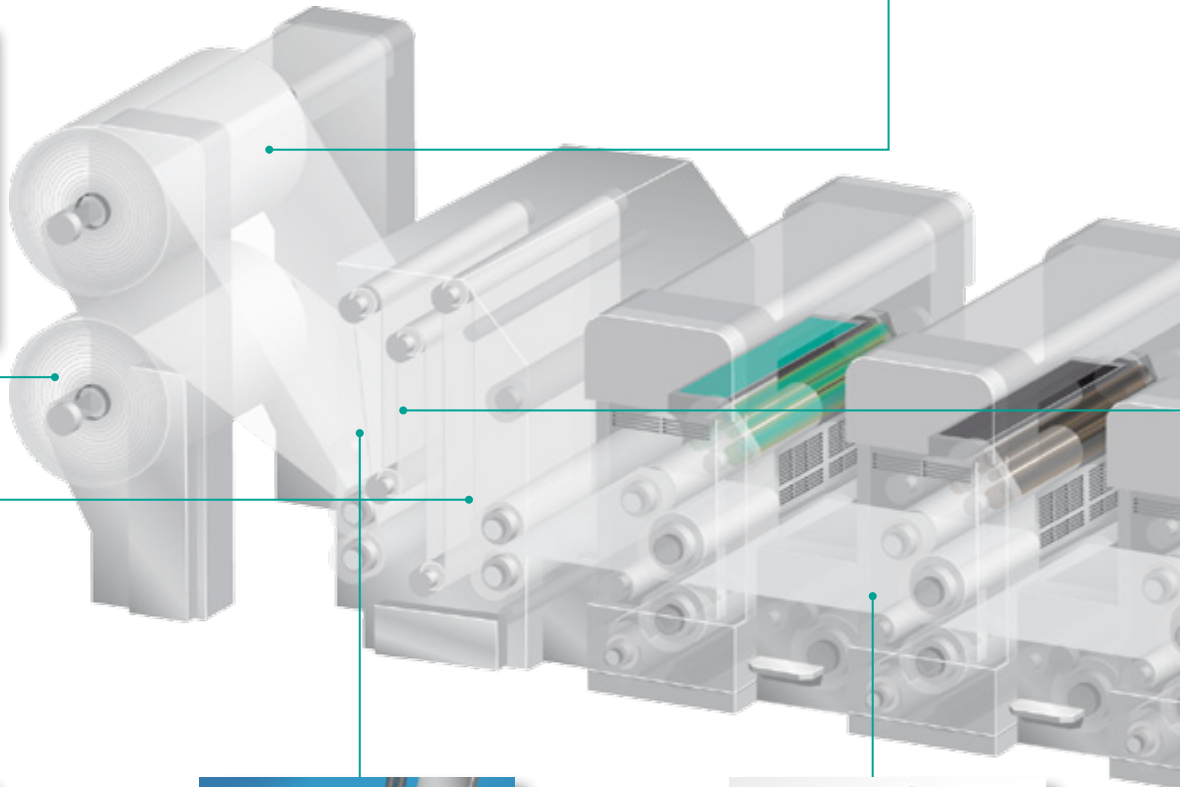
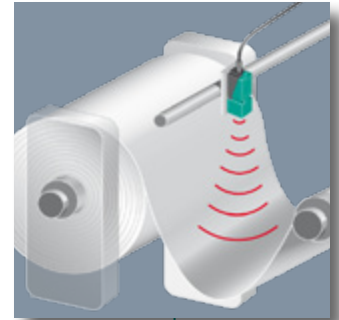

## WEB BREAK MONITORING

### PHOTOELECTRIC AND ULTRASONIC SENSORS MLV41-8-HV, UB120-12GM

- Easy setup and diagnostics
- Reduces scrap
- Tamperproof or adjustable versions available
- Compact housings

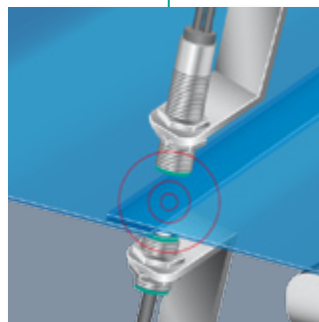

## SPLICE DETECTION

### ULTRASONIC SENSORS UGB-18GM

- Reduces waste by identifying web splices
- Accurately detects manufacturer's, automatic, and manual splices
- Capable of double layer and label detection
- Operates with printed, colored, and glossy surfaces
- Simple, quick alignment and setup

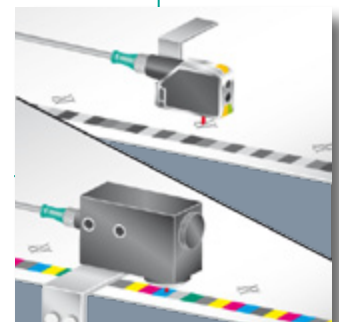

## PRINT MARK TRIGGER

### CONTRAST AND COLOR SENSORS DK10, DK12, DK20/21, DK31/34

- Compact, rugged housings
- Adjustable connector positions
- High-visibility, dual-indicator LEDs
- Static and dynamic Teach-In
- 4-in-1 output minimizes inventory

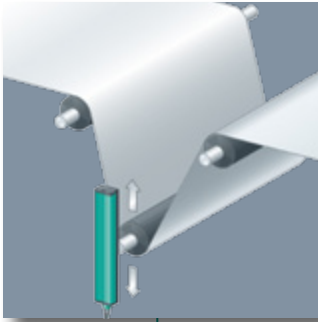

#### WEB TENSION CONTROL

##### INDUCTIVE POSITIONING SYSTEMS PMI-F110, PMI-F90

- Wear-free position detection
- Precise resolution
- Insensitive to dust, oil and grease

#### INK LEVEL DETECTION

##### ULTRASONIC SENSORS UC300-F43, UB300-18GM

- Reliable ink level measurement
- Low-level alarm
- Chemically-resistant housings

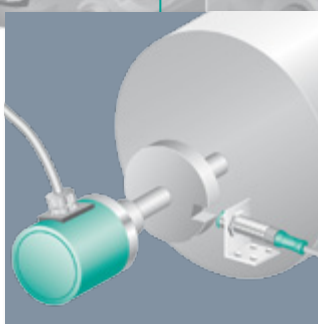
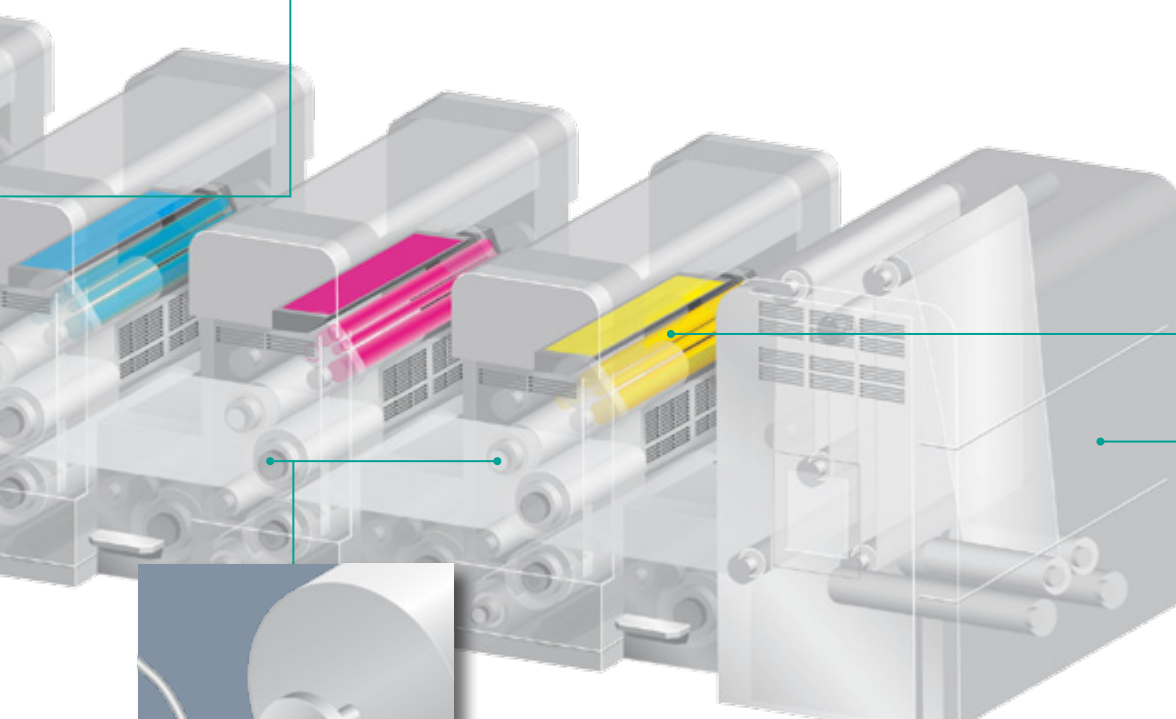
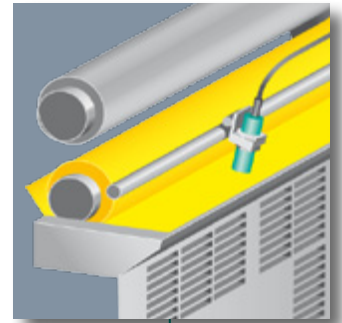

#### CYLINDER AND PART POSITION

##### INDUCTIVE SENSORS, ENCODERS

- Precise detection of metal gear teeth, notches, and cams
- Reduction factor 1 senses all metals at the same distance
- Wide variety of housings and sensing ranges

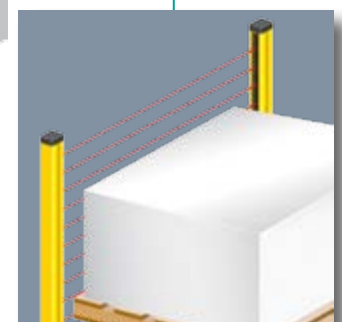

#### SAFETY PROTECTION AT DELIVERY

##### SAFETY LIGHT CURTAINS SLCS, SLCT

- Self-contained "2 box" evaluation system
- Ultra-slim housing design
- SLCT Type 2, SIL2
- SLCS Type 4, SIL3

## DOUBLE SHEET DETECTION

### ULTRASONIC SENSORS UDC-18GM

- Identifies zero, one, or multiple (overlapping) sheets
- Fast response time
- Extremely wide media spectrum, including fine papers, transparencies, cardboard, glossy surfaces, and metal foils

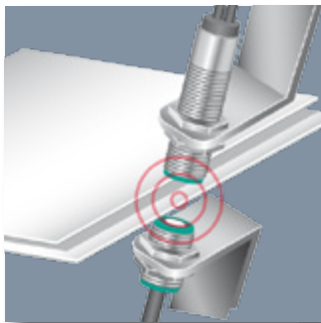

## PRINT MARK DETECTION

### CONTRAST AND COLOR SENSORS DK12, DF12

- Compact, rugged, die-cast housing
- Adjustable connector position
- High-visibility, dual-indicator LEDs
- Static and dynamic Teach-In
- 4-in-1 output minimizes inventory

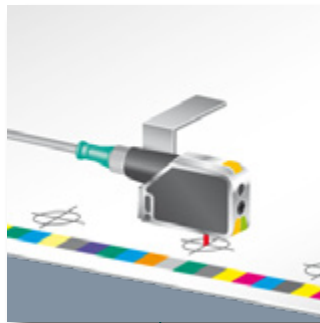

## SHEET PRESENCE/EDGE DETECTION

### DIFFUSE MODE AND SLOT SENSORS GL, ML4.2, SU18, SU19

- Consistent front and lateral alignment
- Enhanced precision with background suppression sensors
- 4-in-1 output eliminates additional inventory
- Wide range of housing sizes available

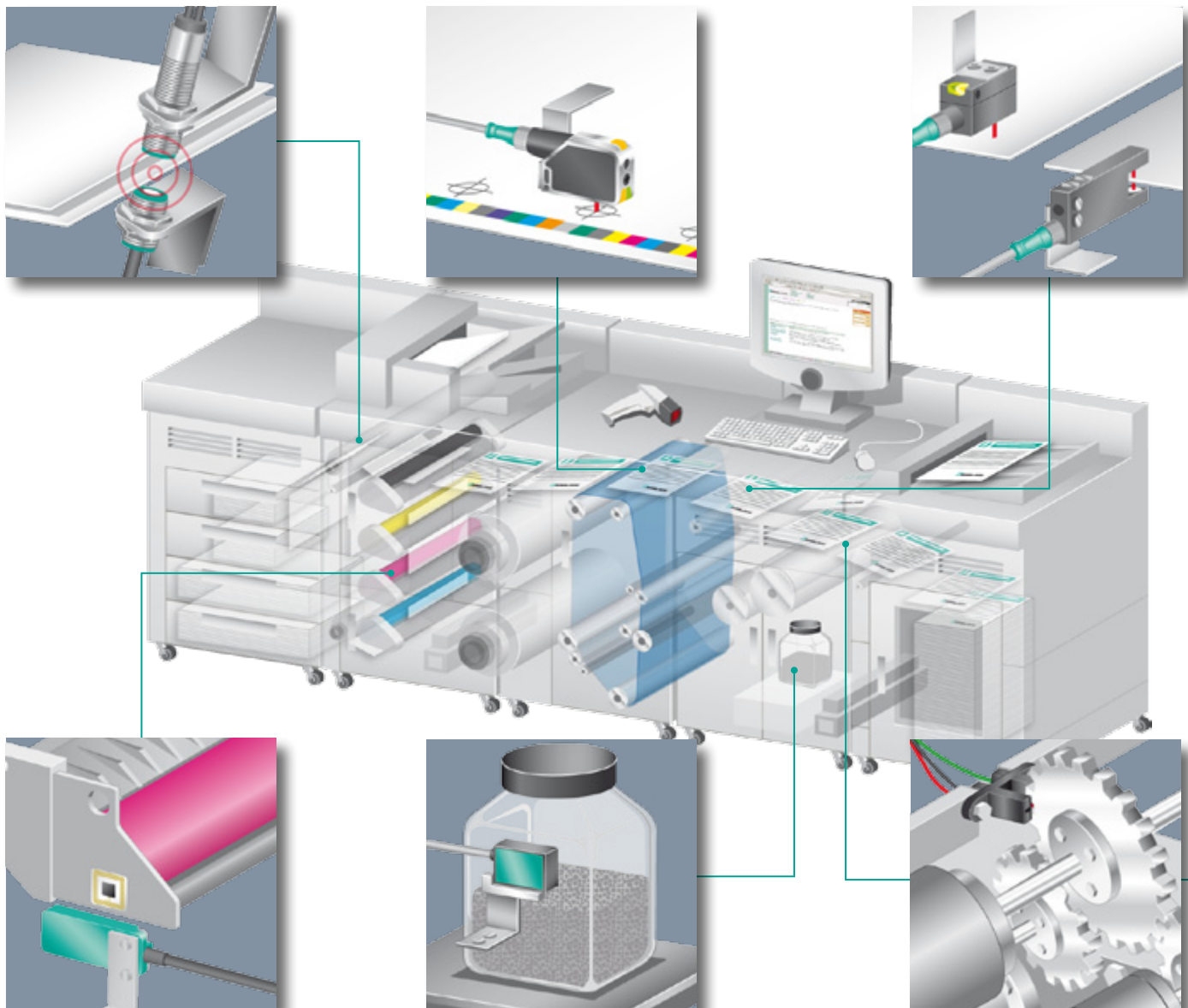
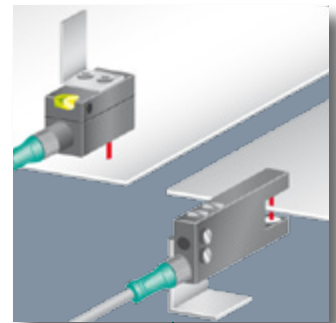

## CONSUMABLES IDENTIFICATION

### RFID

- RFID enables automatic identification of consumables
- Tracking and tracing
- Reliable identification in harsh environments

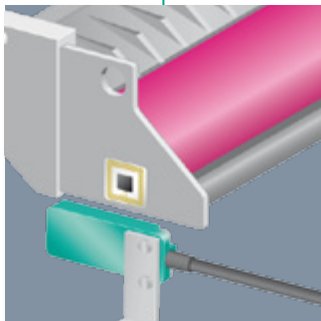

## TONER LEVEL

### CAPACITIVE SENSORS CBN12-F64, CBN10-F46

- Reliably detects granular or powdered ink substances
- Detect contents through toner cartridge/waste bottles
- Tried and tested technology

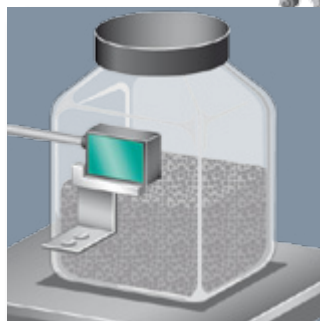

## LOW COST POSITION FEEDBACK

### SLOT SENSORS GL2, GL3, GL5

- Compact, cost-effective, accurate
- Designed to fit in tight spaces
- Extremely fast response time
- Easy mounting
- Wide variety of housing styles

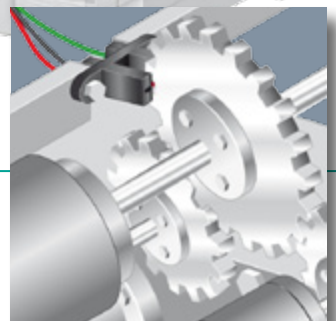



## SHEET PRESENCE

### DIFFUSE MODE SENSORS MLV41, ML4.2, R2

- Reliable media detection due to low black-to-white difference and good background suppression
- Various housing shapes available
- Antistatic glass window prevents false switching due to dust

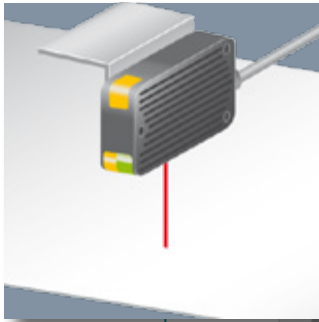

## SHEET VERIFICATION

### VISION SENSORS BIS510, VOS412-BIS

- Sheet verification by image comparison, barcode and Data Matrix code reading in one sensor
- For high-speed applications
- Optimized illumination ensures reliable verification also on reflective surfaces



## STACK HEIGHT MONITORING

### THRU-BEAM SENSORS MLV41, ML4.2, R2

- Reliable detection due to small black-to-white difference
- Small, sharp light beam
- 4-in-1 output
- Antistatic lens repels paper dust

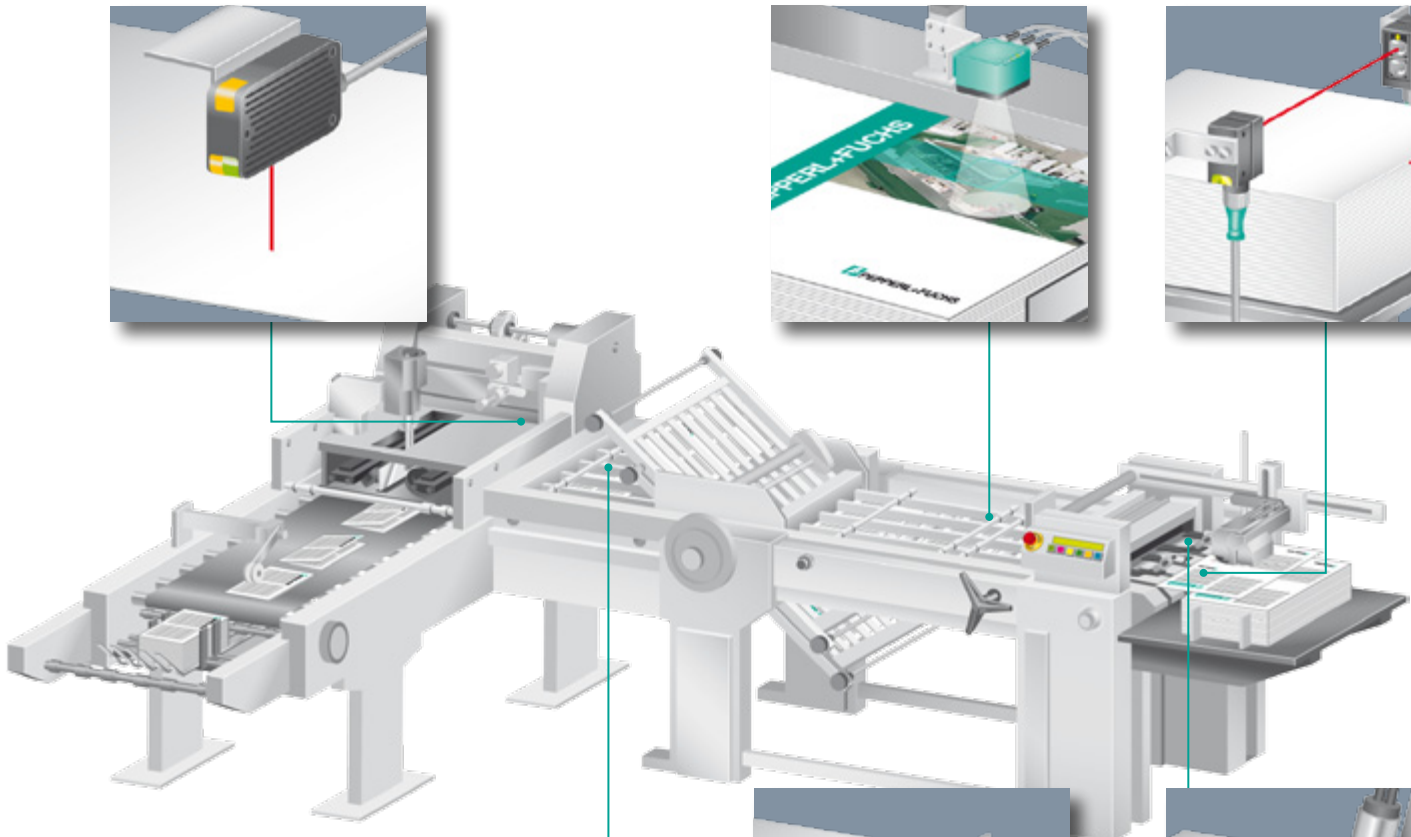
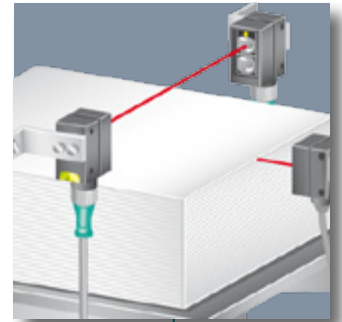

## SHEET EDGE TRIGGER/TRANSPARENT SHEET DETECTION

### DIFFUSE MODE AND RETROREFLECTIVE SENSORS ML4.2, ML4.2-54-G, R2

- Consistent front and lateral alignment
- Enhanced precision with background suppression sensors
- Protected against paper dust and vibration
- 4-in-1 output eliminates additional inventory
- Transparent sheet detection

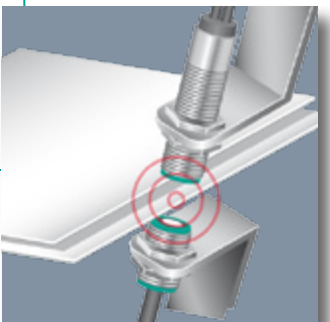
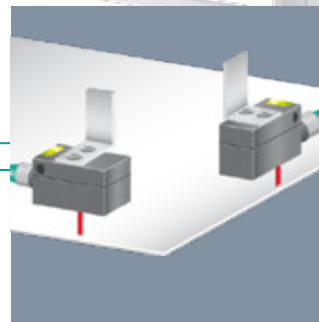

## DOUBLE SHEET DETECTION

### ULTRASONIC SENSORS UDC-18GM

- Identifies zero, one, or multiple (overlapping) sheets
- Fast response time
- Extremely wide media spectrum, including fine papers, transparencies, cardboard, glossy surfaces, and metal foils

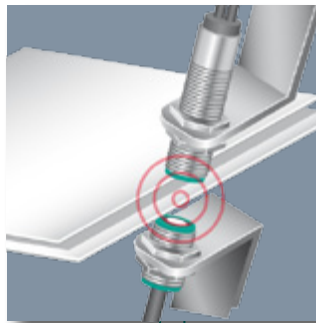
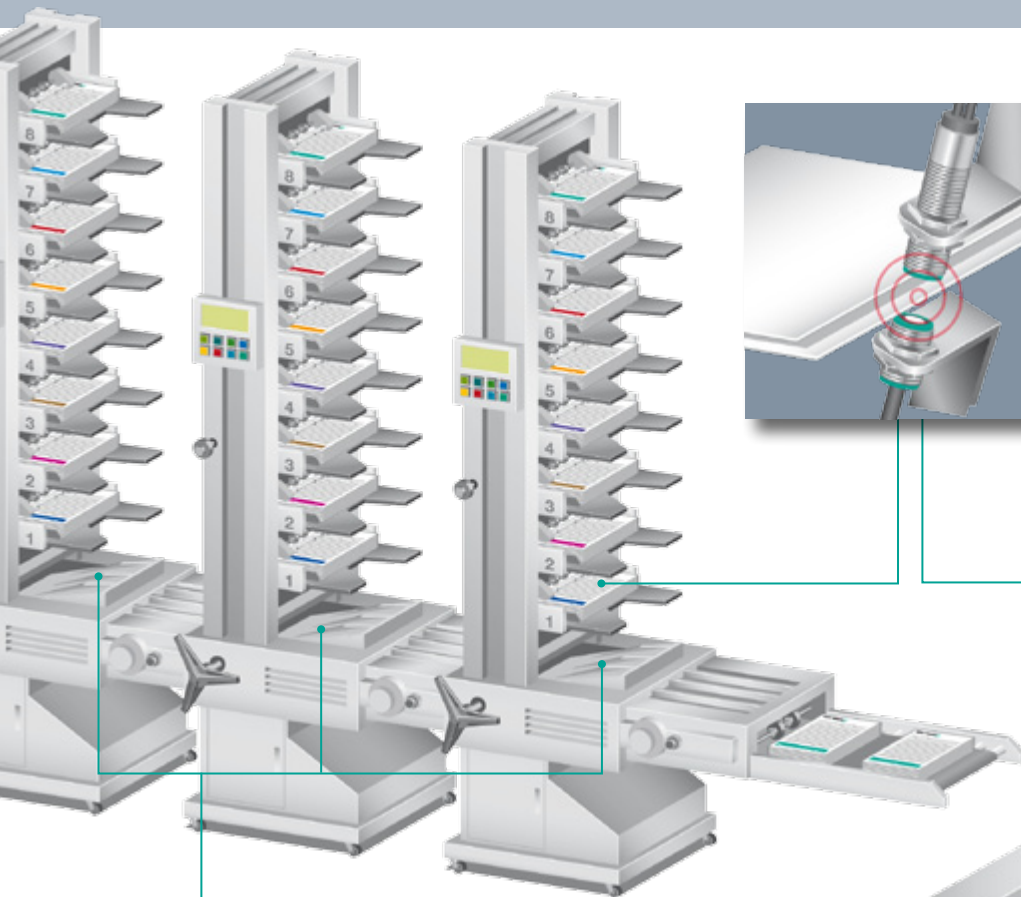

## DOUBLE SHEET DETECTION

### ULTRASONIC SENSORS UDC-18GM

- Identifies zero, one, or multiple (overlapping) sheets
- Fast response time
- Extremely wide media spectrum, including fine papers, transparencies, cardboard, glossy surfaces, and metal foils

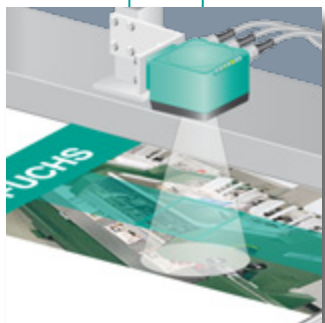

## SHEET VERIFICATION

### VISION SENSORS BIS510, VOS412-BIS

- Sheet verification by image comparison, barcode and Data Matrix code reading in one sensor
- For high-speed applications
- Optimized illumination ensures reliable verification also on reflective surfaces

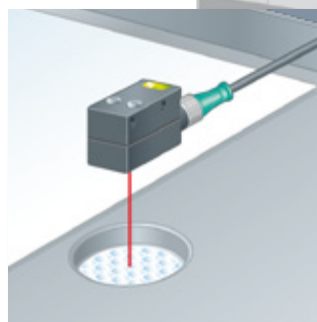
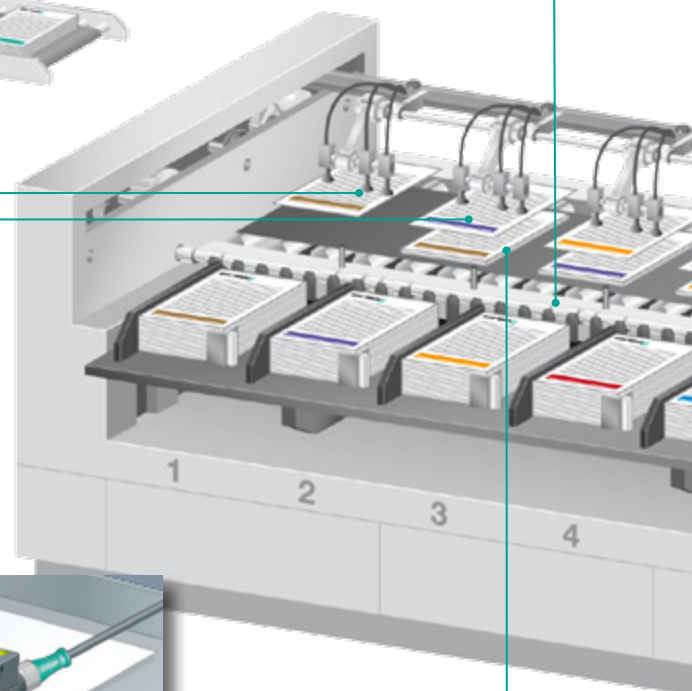

## SHEET PRESENCE/TRANSPARENT SHEET DETECTION

### RETROREFLECTIVE SENSORS ML4.2, ML4.2-54-G, ML6, ML6-54-G, R2

- Fast and accurate detection of a wide variety of media
- Reliable detection of transparent materials
- Precise sheet edge detection
- Adjustable contrast, no blind range
- 4-in-1 output minimizes inventory

## CODE READING

### VISION SENSORS OPTICAL PRINT INSPECTOR

- High speed reading of 1-D and 2-D codes
- Multicode reading
- Code quality output
- Reads very long barcodes by taking several images
- Logo comparison

### LASER BARCODE SCANNER VB14N, VB6

- Reads all popular 1-D codes
- Raster scanner option
- Advanced code reconstruction algorithm
- Quick and easy programming and setup

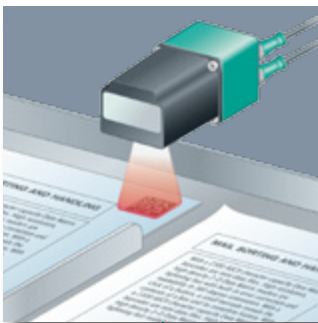

## BOOKLET THICKNESS

### DISTANCE MEASUREMENT DEVICES VDM18, VDM28

- Precise detection of stack or booklet height
- High-resolution laser triangulation ensures all pages have been assembled
- Accurate height detection regardless of media color

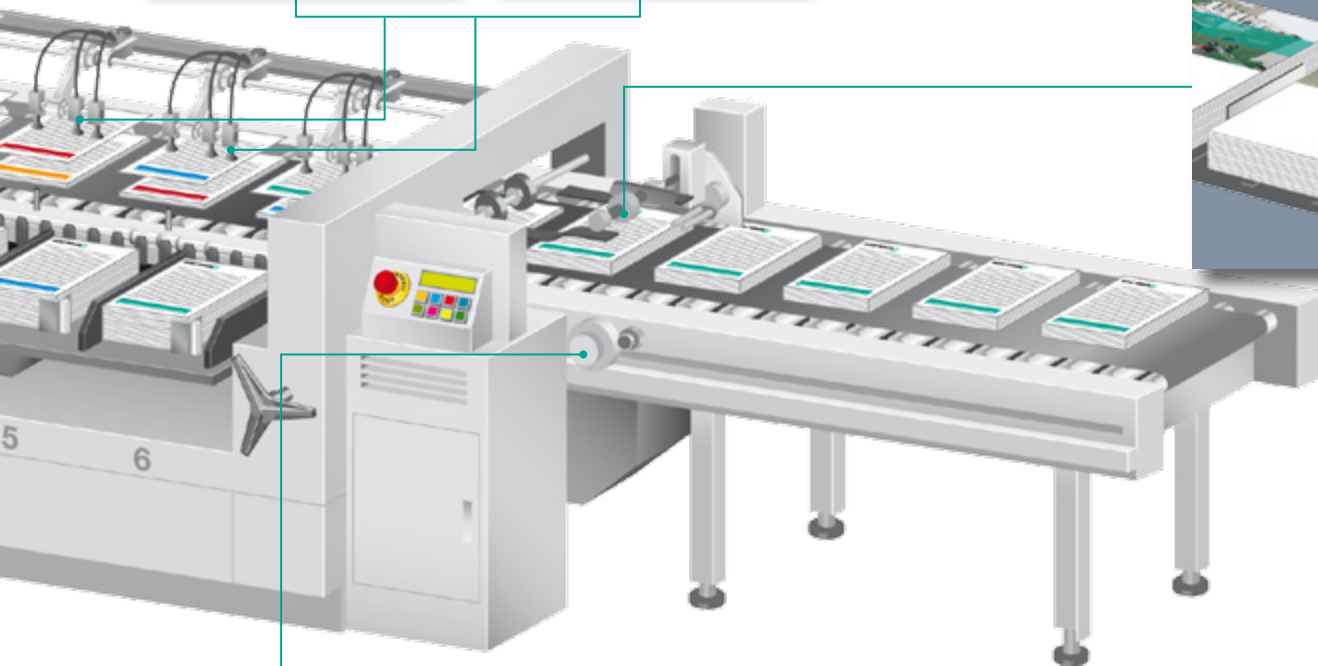
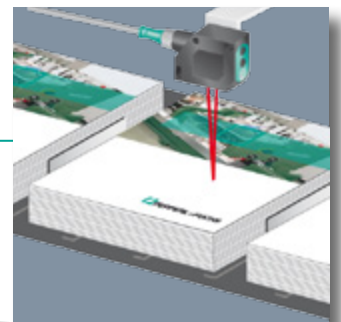

## CYLINDER AND PART POSITION

### INDUCTIVE SENSORS, ENCODERS

- Precise detection of metal gear teeth, notches, and cams
- Reduction factor 1 senses all metals at the same distance
- Wide variety of housings and sensing ranges

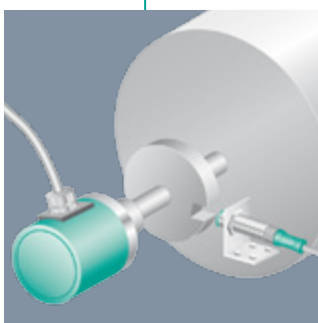

## STITCHING TRIGGER POSITION

### RETROREFLECTIVE SENSORS ML4.2

- Detection of collated signatures for proper stitching
- No blind range
- High switching accuracy
- Scratch-resistant glass lens

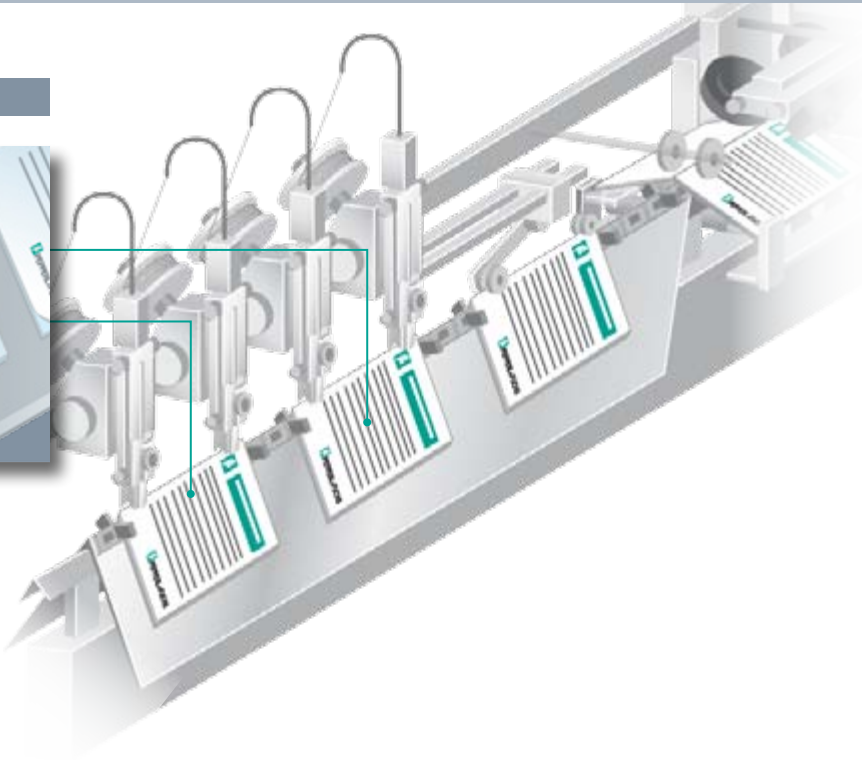
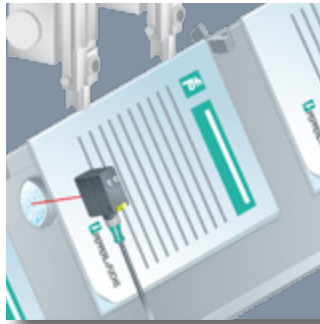

## SHEET VERIFICATION

### VISION SENSORS BIS510, VOS412-BIS

- Sheet verification by image comparison, barcode and Data Matrix code reading in one sensor
- For high-speed applications
- Optimized illumination ensures reliable verification also on reflective surfaces

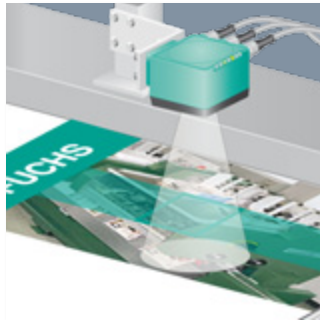

## DOUBLE SHEET DETECTION

### ULTRASONIC SENSORS UDC-18GM

- Identifies zero, one, or multiple (overlapping) sheets
- Fast response time
- Extremely wide media spectrum, including fine papers, transparencies, cardboard, glossy surfaces, and metal foils

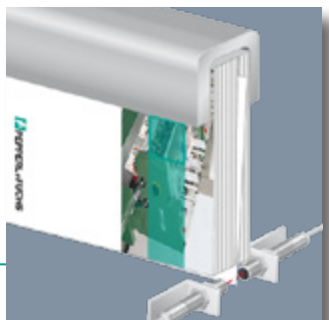
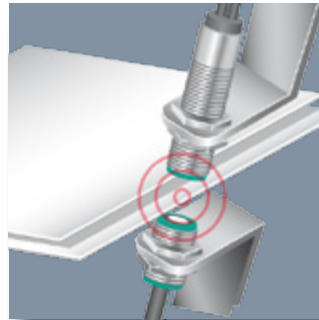

## BOOK POSITION

### THRU-BEAM AND SLOT SENSORS E18/EV18-LAS, GL

- Checks booklet edge to ensure all pages are properly bound
- Narrow laser beam detects hanging sheets due to improper binding

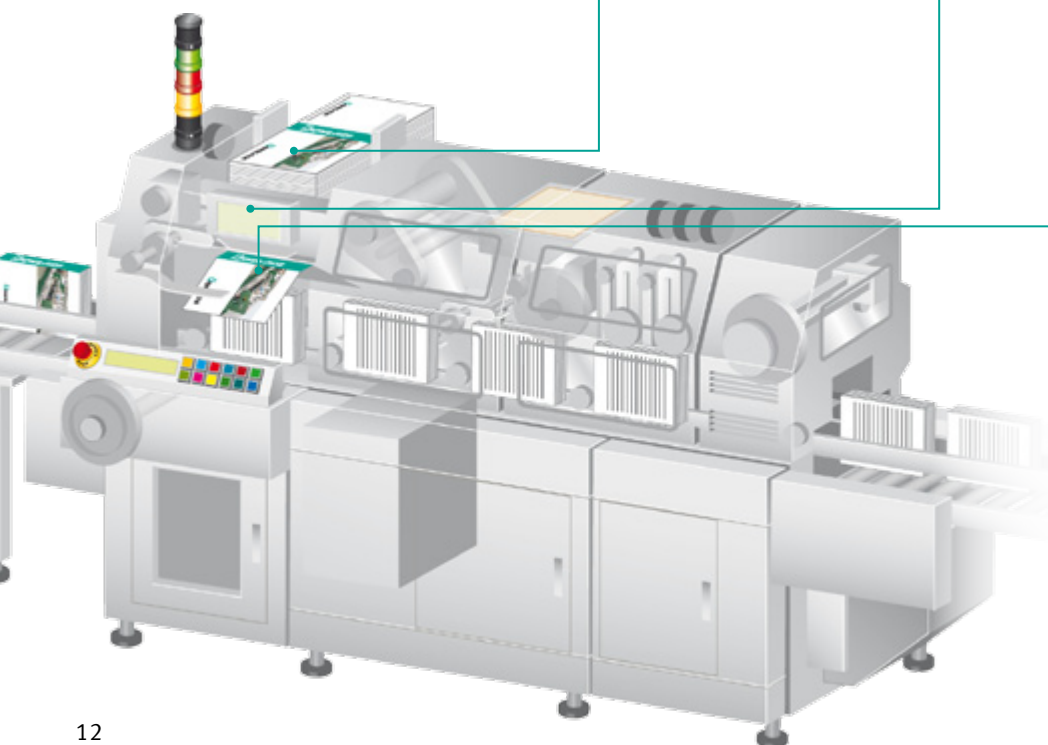

## DOUBLE SHEET DETECTION

### ULTRASONIC SENSORS UDC-18GM

- Identifies zero, one, or multiple (overlapping) sheets
- Fast response time
- Extremely wide media spectrum, including fine papers, transparencies, cardboard, glossy surfaces, and metal foils

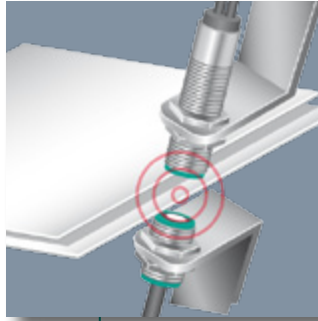

## TRANSPARENT SHEET DETECTION

### RETROREFLECTIVE SENSORS ML4.2-54-G, ML6-54-G, MLV41-54-G

- Reliable detection of transparent materials
- No blind range
- Adjustable contrast
- 4-in-1 output eliminates additional inventory

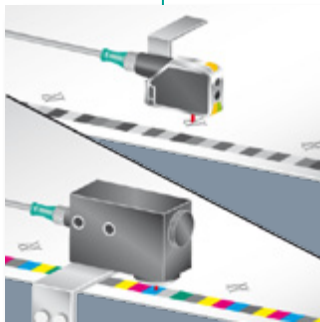
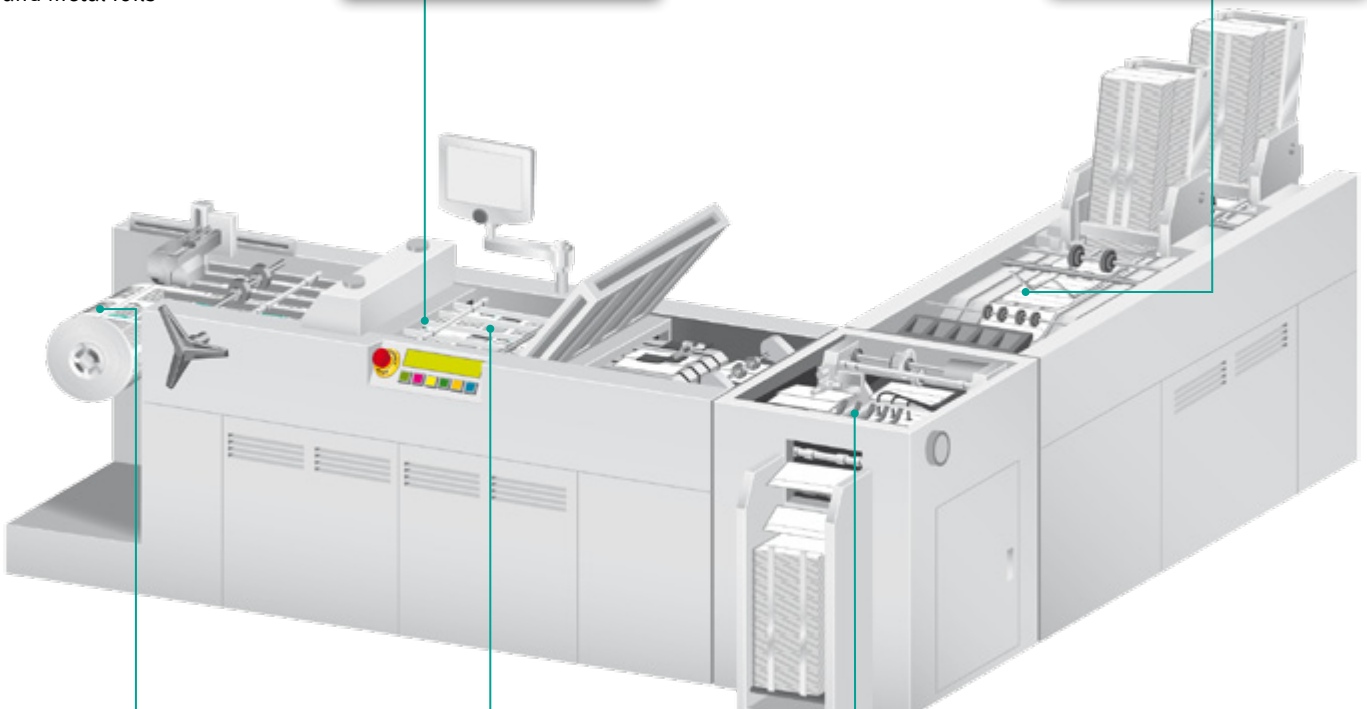
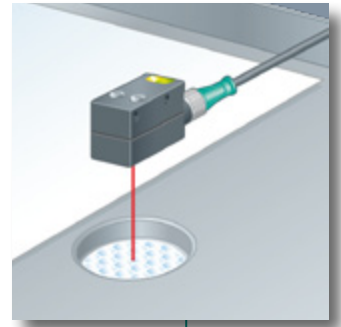

## PRINT MARK TRIGGER

### CONTRAST AND COLOR SENSORS DK10, DK20/21, DK31/34

- Compact, rugged, die-cast housing
- Adjustable connector position
- High-visibility, dual-indicator LEDs
- Static and dynamic Teach-In
- 4-in-1 output minimizes inventory

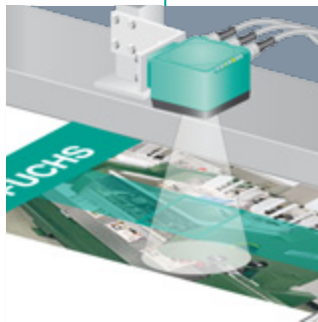

## SHEET VERIFICATION

### VISION SENSORS BIS510, VOS412-BIS

- Sheet verification by image comparison, barcode and Data Matrix code reading in one sensor
- For high-speed applications
- Optimized illumination ensures reliable verification also on reflective surfaces

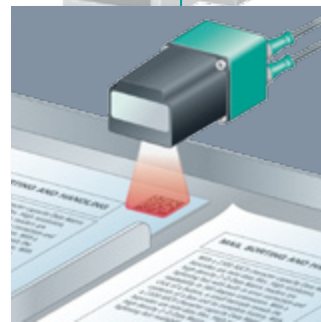

## CODE READING

### VISION SENSORS OPTICAL PRINT INSPECTOR

- High speed reading of 1-D and 2-D codes
- Multicode reading
- Code quality output
- Reads very long barcodes by taking several images
- Logo comparison



### LASER BARCODE SCANNER VB14N, VB6

- Reads all popular 1-D codes
- Raster scanner option
- Advanced code reconstruction algorithm
- Quick and easy programming and setup

## STACKER SAFETY

### SAFETY LIGHT CURTAINS SLCS, SLCT, SLP, SafeBox

- Safety light curtains detect entry into hazardous areas
- Safety categories 2 and 4
- Narrow beams provide immunity to interference from reflective surfaces
- SafeBox modular safety controller connects all safety components into one unit

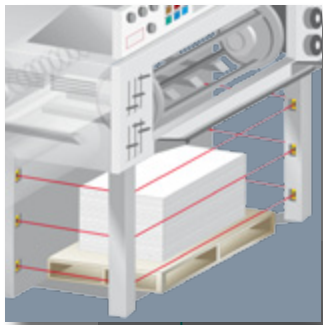

## DOUBLE SHEET DETECTION

### ULTRASONIC SENSORS UDC-18GM

- Identifies zero, one, or multiple (overlapping) sheets
- Fast response time
- Extremely wide media spectrum, including fine papers, transparencies, cardboard, glossy surfaces, and metal foils

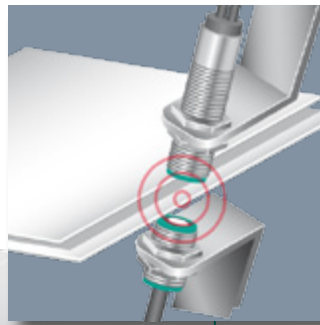

## SHEET ALIGNMENT (FRONT LAY, SIDE LAY)

### DIFFUSE MODE SENSORS ML10, KT10, ML4.2

- Fast and accurate detection of a wide variety of media
- Small black-to-white difference with superior background suppression
- Wide variety of sensor styles for use in tight spaces
- Protected against paper dust and vibration
- 4-in-1 output minimizes inventory

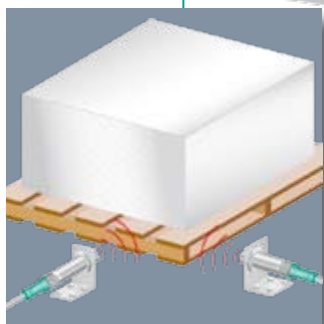
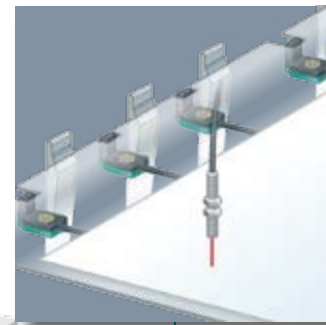

## PALLET DETECTION

### DISTANCE MEASUREMENT DEVICES UB500-18GM, UB500-F54, UC500-L2, VDM28

- Precise detection of position regardless of pallet color or finish
- Analog and discrete outputs
- Ultrasonic and photoelectric solutions



## STACK LIMIT DETECTION

### INDUCTIVE SENSORS VariKont

- Reliable detection of stack lift limit
- Insensitive to paper dust and lubricants
- Compact housing, wear-free detection

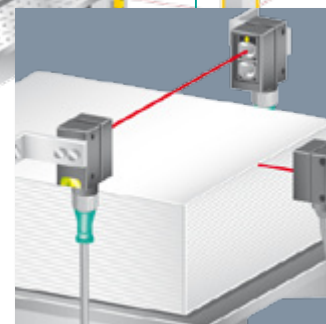

## STACK HEIGHT MONITORING

### THRU-BEAM SENSORS ML4.2, MLV41, MLV12

- Reliable detection due to small black-to-white difference
- Small, sharp light beam
- 4-in-1 output
- Antistatic lens repels paper dust

# STACK TURNERS

## OPERATOR SAFETY PROTECTION

### SAFETY LIGHT CURTAINS SLCS, SLCT, SLP, SafeBox AS-INTERFACE SAFETY AT WORK

- Monitors status of the safety inputs with one relay
- Network all e-stops, door interlocks, light curtains, etc. on one cable
- Significantly simplifies cabling

## INCLINATION MEASUREMENT

### INCLINATION SENSORS F99

- Noncontact sensing of the inclination angle in one or two axes
- Angular resolution 0.1°
- Both analog and switching outputs
- Two adjustable switching points

## ROTATION CONTROL

### ENCODERS, POSITIONING SYSTEMS PMI360

- Precise product positioning
- Compact encoder for tight spaces
- Ultrafast response time

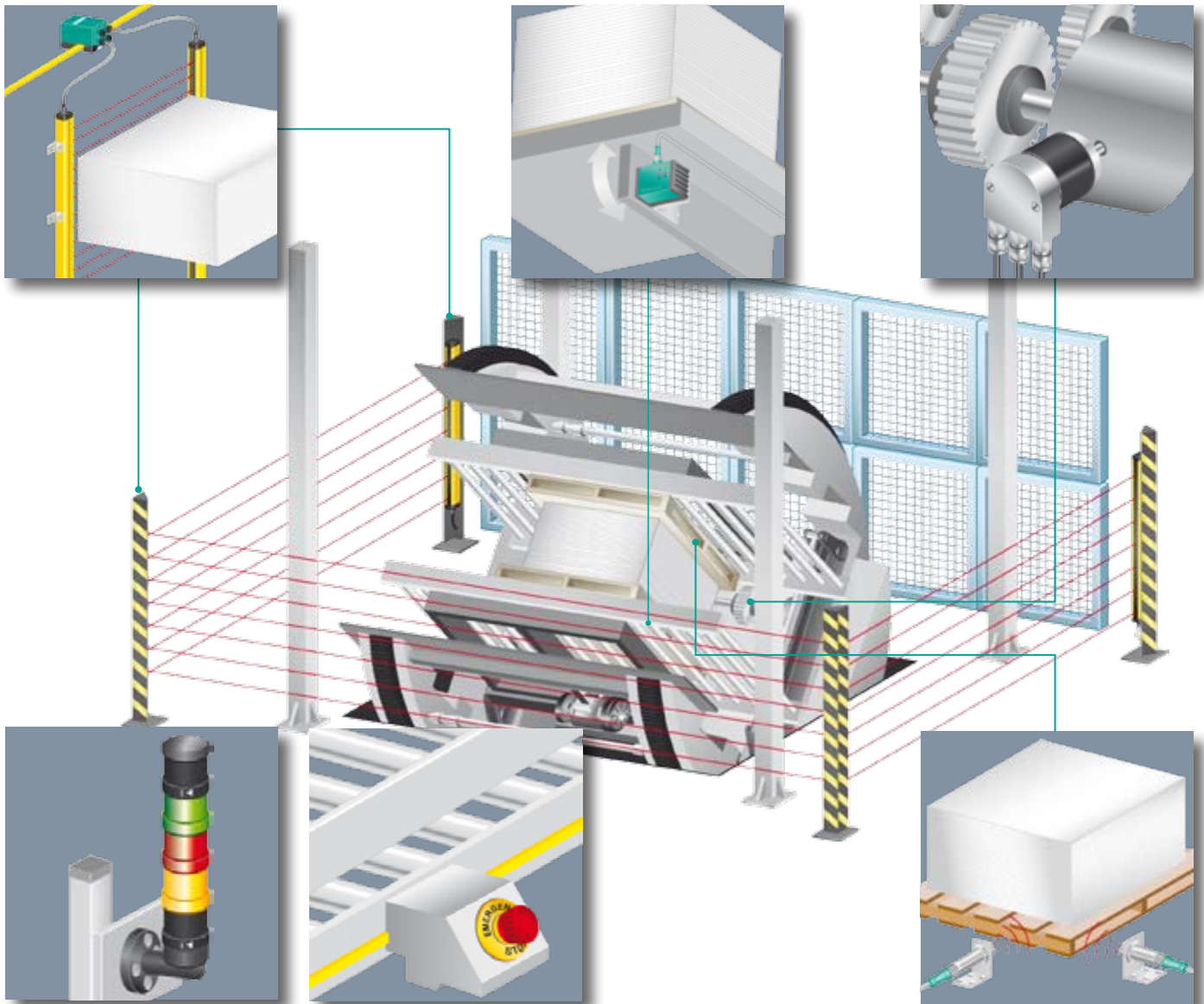

## STACK LIGHT/E-STOP

### AS-INTERFACE SAFETY AT WORK STACK LIGHT

- Compatible with AS-Interface
- Various color configurations and mounting options
- Audible alarms

### E-STOP

- Illuminated and non-illuminated versions
- Integrated AS-Interface Safety at Work technology
- Twist and pull release

## PALLET POSITIONING

### DISTANCE MEASUREMENT DEVICES UB500-18GM, UB500-F54, UC500-L2, VDM28

- Precise detection of position regardless of pallet color or finish
- Analog and discrete outputs
- Ultrasonic and photoelectric solutions

# SHEET VERIFICATION AND CODE READING

## THE NUMBER 1 FOR SHEET VERIFICATION

The powerful BIS510 sensor is the number 1 sensor for sheet verification in all common collating, folding, and binding machines. The vision sensor ensures safe sheet verification in high-speed applications by image comparison and 1-D and 2-D code reading.

- Automatic Teach-In of reference sheets
- Reliable detection of misfed sheets in sheet sequences
- Safe detection even on reflective surfaces
- Innovative image processing technology ensures reading of very large barcodes

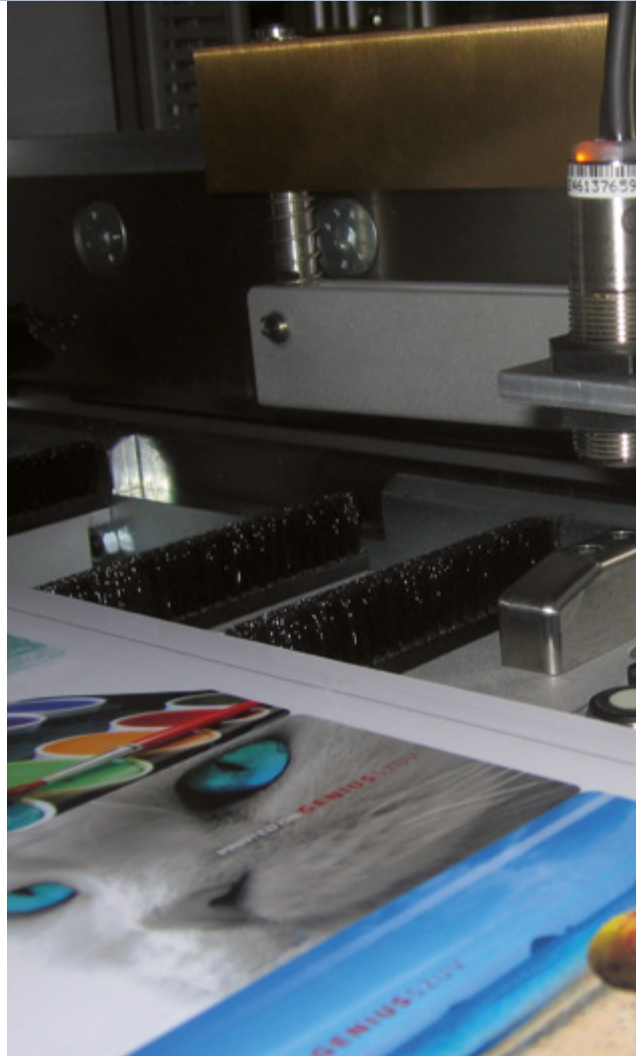

## FAST AND VERSATILE CODE READING

The Optical Print Inspector from Pepperl+Fuchs is the versatile solution for code reading in the paper, printing, and packaging industry. It offers a number of powerful functions:

- Multicode reading
- Code quality output
- Match code function
- Logo comparison

The sensor reads Data Matrix, Code 2/5, Code39, Code128, and Pharmacode symbologies at high speeds of up to 10 m/s at 30 readings/s.

It can also reliably capture and read very long barcodes by taking several images. The large depth of focus of 120 mm allows code reading for varying distances with one setting.

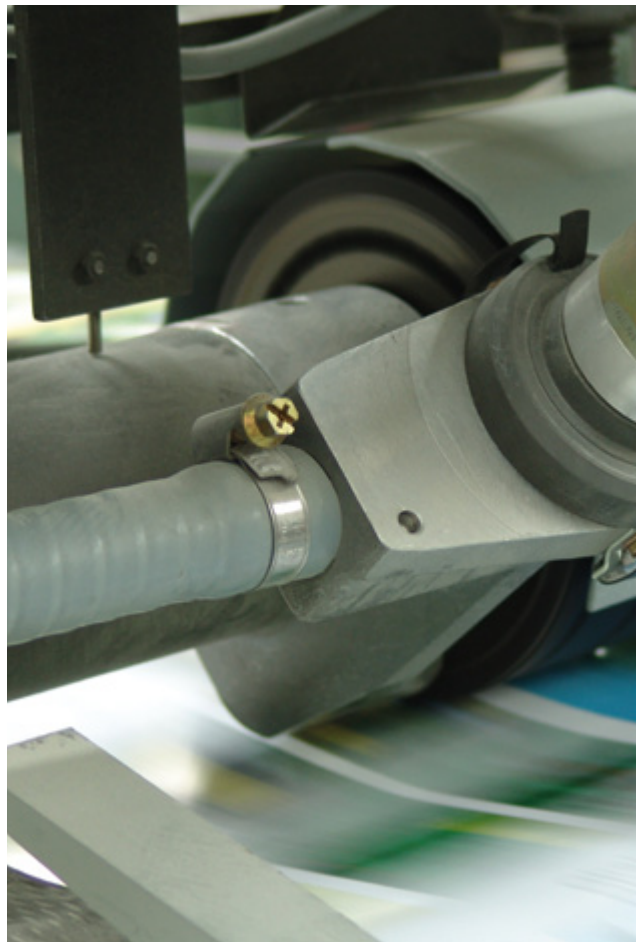



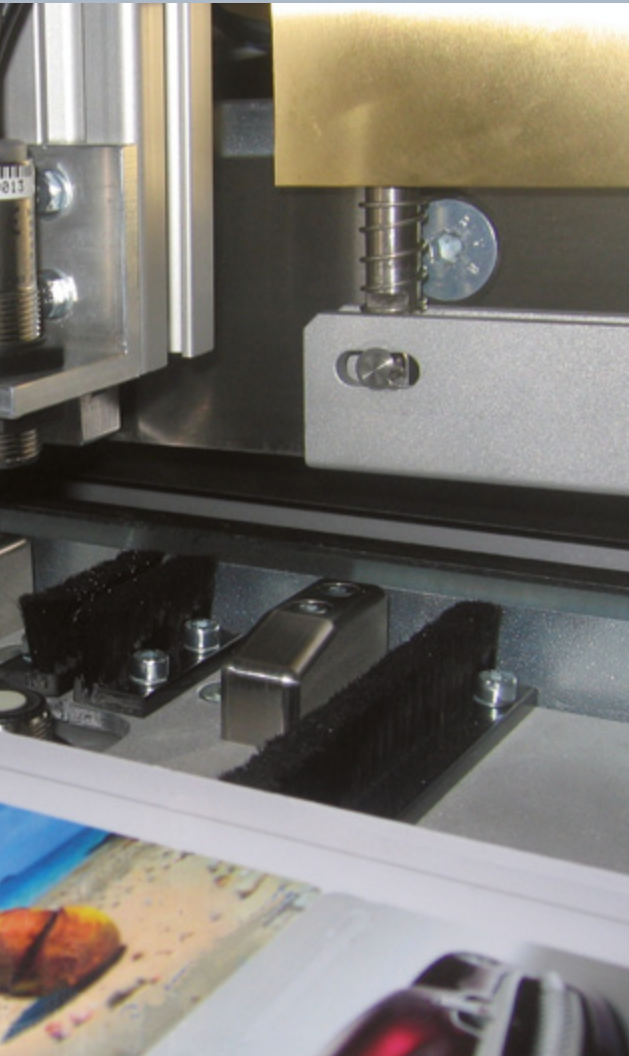

## ULTRASONIC DOUBLE SHEET DETECTION

Double sheet detection using the ultrasonic sensors UDC-18GM Series has proven itself in the printing and packaging industry. Printing machine downtime and high repair costs due to double sheet events can now be eliminated. Ultrasonic double sheet detection sensors UDC-18GM provide enhanced machine run-time and minimize material waste.

Highlights of the UDC-18GM Series:

- Insensitive to printing, colors and reflective surfaces
- Robust and insensitive to dust
- No Teach-In required
- Fast response time
- Great mounting flexibility, easily fits into tight spaces

With the software tool (Device Type Manager of UDC-18GM) process and diagnostic data can be monitored, for example in case a double sheet was detected. The amplitude response allows the user to evaluate the sensor signals.



## PHOTOELECTRIC MINIATURE PRECISION SENSORS

Our photoelectric product portfolio of miniature precision sensors range from background suppression to retroreflective sensors and laser pointer. The miniature sensors are used for precise sheet alignment, sheet presence and edge detection in prepress, press, or postpress machines.

Detectable targets range from deep black, reflective to transparent materials. Infrared light and the triangulation principle guarantee switching accuracy, even under heavy dust. The switching accuracy has a direct impact on the laser-engraving process, the print result or the die-cutting precision.

Highlights:

- Very high degree of switching accuracy
- Precise object and edge detection
- Miniature housing easily fits into tight spaces



# SELECTION GUIDE

		Sheet Fed Printing	Web Fed Printing	Digital Printing/ ATMs	Folding	Collating	Stitching, Binding	Mailroom	Die Cutting	Stack Turners
PHOTOELECTRIC	ML4.2	■	■	■	■	■	■	■	■	
	ML6	■	■	■	■	■	■	■	■	
	R2	■	■	■	■	■	■	■	■	
	MLV12	■	■	■		■			■	
	MLV41	■	■		■	■	■			
	RL28		■							■
	KT10	■		■					■	
	M18...LAS-P	■			■				■	■
	E18/EV18-LAS	■				■	■		■	
	SU18			■		■		■		
	SU19			■		■		■		
	DK10, DK12, DK20/21, DK31/34		■	■				■		
	DF12, DF20		■	■				■		
	ML10 + SU100/SU180	■			■			■	■	
	GL2 .. GL5			■		■	■			
	VDM18			■		■		■		
	VDM28		■	■			■			■
	SLCT	■	■						■	■
	SLCS	■	■						■	■
SLP, SLPCM	■	■						■	■	
SafeBox	■	■						■	■	
SLA12-LAS	■	■						■	■	
VISION	Optical Print Inspector					■	■	■		
	VOS412-BIS				■	■	■	■		
	BIS510				■	■	■	■		
	Barcode VB14N, VB6					■	■	■		
INDUCTIVE	M4	■	■	■	■	■	■	■	■	■
	M5	■	■	■	■	■	■	■	■	■
	M8	■	■	■	■	■	■	■	■	■
	M12	■	■	■	■	■	■	■	■	■
	M18	■	■	■	■	■	■	■	■	■
	M1K	■	■	■	■	■	■	■	■	■
	VariKont	■	■	■	■	■	■	■	■	■
	VariKont L	■	■	■	■	■	■	■	■	■
	F79	■	■	■	■	■	■	■	■	■
	V3	■	■	■	■	■	■	■	■	■
	FP		■							■
	PMI	■	■						■	■
	F99 Inclination Sensor									■
CAPACITIVE	CBN12-F64	■		■	■					
	CBN10-F46			■	■					
	CBN15-30GK	■			■				■	
ULTRASONIC	UC500-L2 VariKont	■							■	■
	UC300-F43	■	■							
	UB500-F54	■	■						■	■
	UB400-F77	■							■	
	UDC-18GM	■		■	■	■	■	■	■	
	UGB-18GM		■	■						
	UB120-12GM		■							
	UB500-18GM	■	■						■	■
UB500-30GM		■								
OTHERS	Encoders	■	■	■	■	■	■	■	■	■
	RFID			■						
	AS-Interface Safety	■							■	■
	Cordsets	■	■	■	■	■	■	■	■	■

# SENSORS FOR THE PRINTING INDUSTRY

## PRECISION PHOTOELECTRIC SENSORS

### SERIES ML10, ML4.2, ML6, MLV41, R2

- Precise and noncontact object and edge detection, acquisition and monitoring
- Sharp background suppression sensors
- Retroreflective and thru-beam sensors
- From miniature to robust design



## OPTICAL IDENTIFICATION

### OPTICAL PRINT INSPECTOR, BIS510, VOS412-BIS, VB14N, VB6

- High speed reading of 1-D and 2-D codes
- Sheet verification for collating, folding and binding machines
- Reading of very large Barcodes
- Powerful functions like multicode reading, code quality output, match code function and logo comparison



## CONTRAST SENSORS AND COLOR SENSORS

### SERIES DK, DF

- Reliable registration and color mark detection
- Splice detection
- Sorting, positioning, quality control
- Very high switching frequency
- Large variety of models, including versions with interchangeable lenses



## INDUCTIVE SENSORS

### SERIES M4, M5, VARIKONT

- Robust and miniature design
- Precise detection of metal
- Wide variety of models



## CAPACITIVE SENSORS

### SERIES F46, F64, M12, M18, M30

- Detection of metal, plastic, liquid or granular materials
- Adjustable sensitivity for more flexibility in application
- Wide variety of models



## ULTRASONIC SENSORS

### SERIES F43, F54, F77, M12, M18, M30, VARIKONT L2

- Noncontact distance measurement
- Insensitive to material, colors and reflective surfaces
- Immune to dust
- Analog or switching outputs



## ULTRASONIC DOUBLE SHEET AND SPLICE DETECTION

### UDC-18GM, UGB-18GM

- Ultrasonic thru-beam sensors detect double sheets and splices
- High-speed detection
- Insensitive to material, colors and reflective surfaces
- Immune to dust



## PHOTOELECTRIC SAFETY SENSORS

### SAFETY LIGHT CURTAINS SLCS, SLCT SERIES, SAFEBOX

- From single-beam safety thru-beam sensors to multi-beam machine protection
- Finger protection, hand protection and body protection
- Integrated evaluation or evaluation using SafeBox



## INDUCTIVE POSITIONING SYSTEM

### PMI

- Precise positioning
- Linear position measurement or rotation angle measuring
- Wear-free, robust and immune to dust and noise

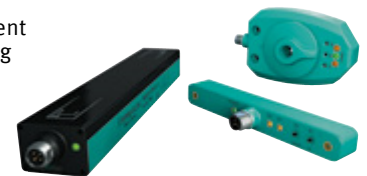

## ROTARY ENCODERS

### SERIES RVI58, RVS58S, CVM58

- Positioning tasks and detection of rotational movements
- Incremental and absolute rotary encoders
- Single-turn and multi-turn versions
- Certified functional safety for plants up to SIL3 and PLE

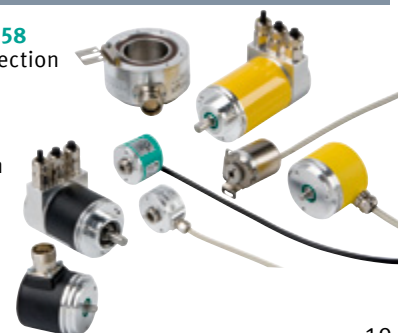

# FACTORY AUTOMATION – SENSING YOUR NEEDS



Pepperl+Fuchs sets the standard in quality and innovative technology for the world of automation. Our expertise, dedication, and heritage of innovation have driven us to develop the largest and most versatile line of industrial sensor technologies and interface components in the world. With our global presence, reliable service and flexible production facilities, Pepperl+Fuchs delivers complete solutions for your automation requirements – wherever you need us.

## Contact

Pepperl+Fuchs GmbH  
Lilienthalstraße 200  
68307 Mannheim · Germany  
**Tel. +49 621 776-4411 · Fax +49 621 776-27-4411**  
**E-mail: [fa-info@pepperl-fuchs.com](mailto:fa-info@pepperl-fuchs.com)**

## Worldwide Headquarters

Pepperl+Fuchs GmbH · Mannheim · Germany  
E-mail: [fa-info@pepperl-fuchs.com](mailto:fa-info@pepperl-fuchs.com)

## USA Headquarters

Pepperl+Fuchs Inc. · Twinsburg, OH · USA  
E-mail: [fa-info@us.pepperl-fuchs.com](mailto:fa-info@us.pepperl-fuchs.com)

## Asia Pacific Headquarters

Pepperl+Fuchs Pte Ltd · Singapore  
Company Registration No. 199003130E  
E-mail: [fa-info@sg.pepperl-fuchs.com](mailto:fa-info@sg.pepperl-fuchs.com)

[www.pepperl-fuchs.com](http://www.pepperl-fuchs.com)

 **PEPPERL+FUCHS**  
SENSING YOUR NEEDS