

**Expanding possibilities.  
Switching identically.  
Adding value.**

Product Overview  
Reduction Factor 1 Sensors

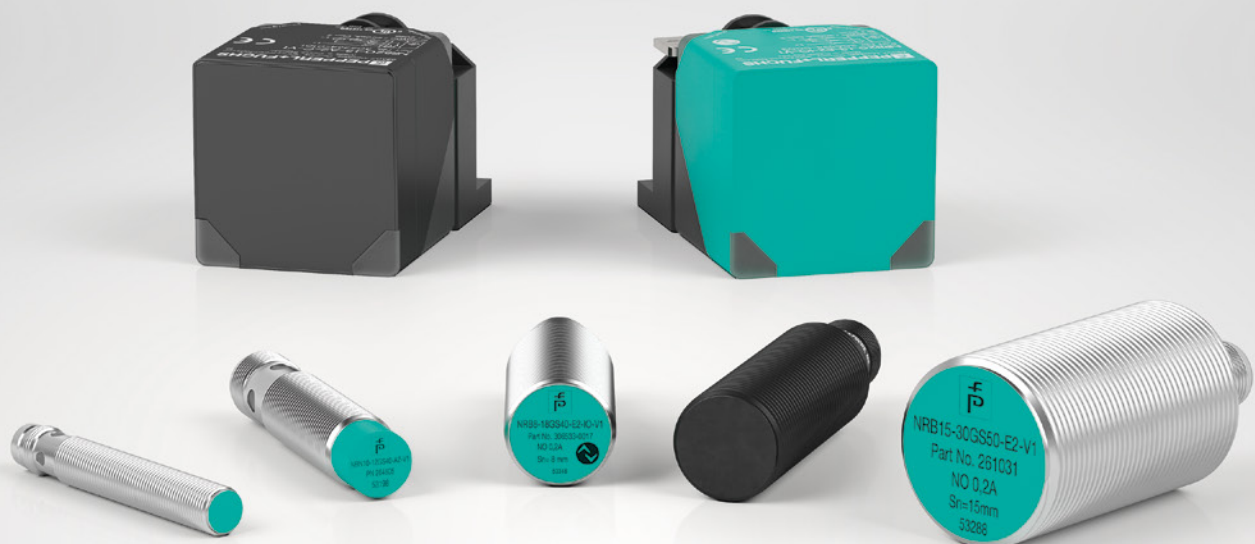

# Proximity Sensors

## The Best Sensing Solutions Directly from the Inventor

As the inventor of the proximity sensor, Pepperl+Fuchs has continuously developed and perfected this noncontact, wear-free technology. Leveraging decades of experience, we have built a comprehensive portfolio of inductive, capacitive, and magnetic sensors that offers the perfect sensing solution for every application.

### Commitment to Quality beyond the Standard

Pepperl+Fuchs' proximity sensors are known for their reliability, innovative features, and high quality. As pioneers in sensing technology, we see it as our responsibility to offer unrivaled quality to customers. We are setting new benchmarks in performance and longevity with test criteria above and beyond standard requirements. With a global sales network and experts that have solved countless applications, we offer application consulting and technical expertise.

### Continuous Portfolio Development

With the invention of the proximity sensor in 1959, Pepperl+Fuchs has the most experience in the field—and we are committed to continuous development of our product portfolio. New reduction factor 1 sensors with IO-Link are proof of this. From fundamental IO-Link functions of identification, configuration, diagnostics, and beyond, reduction factor 1 sensors from Pepperl+Fuchs offer unique features that maximize cost-effectiveness and durability.

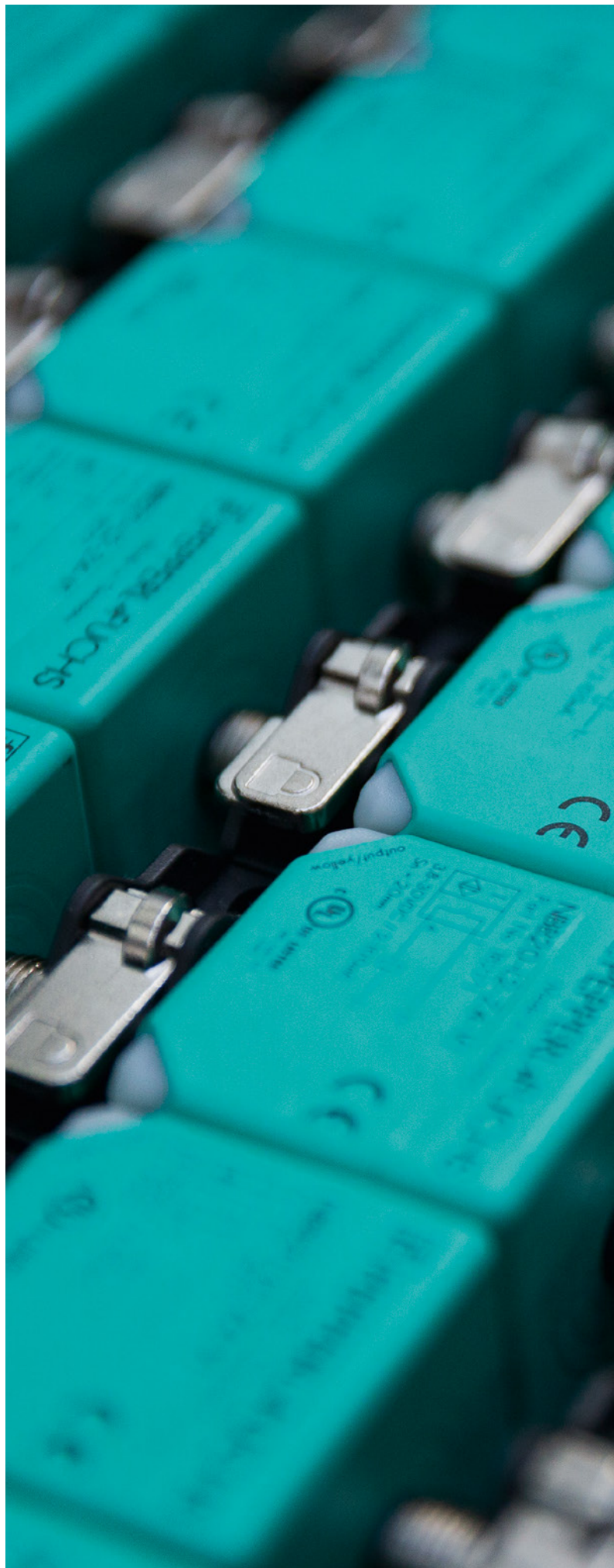



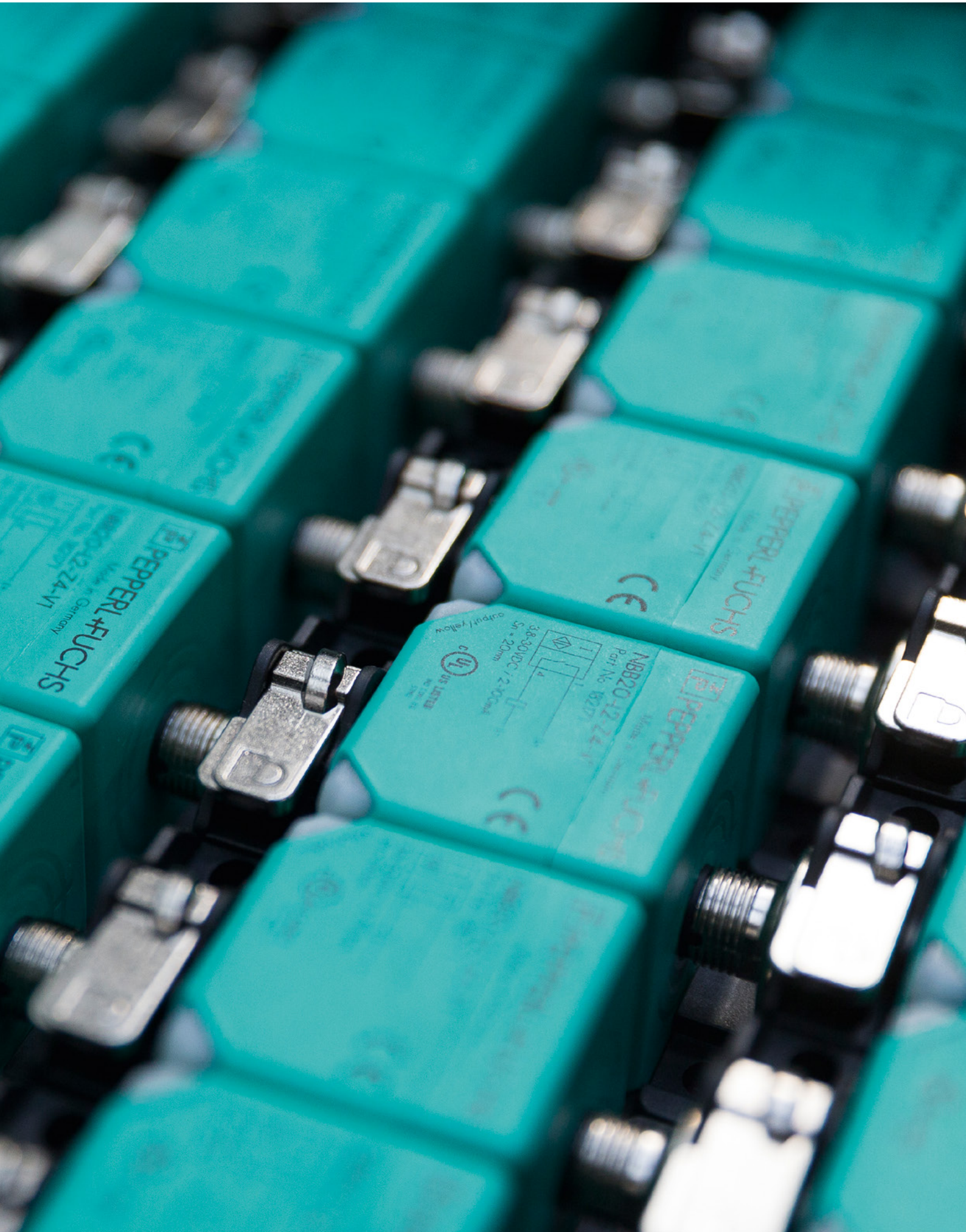

PEPPERL+FUCHS  
NBB20-12-24-V1  
V1.0 08/2010  
Made in Germany



PEPPERL+FUCHS  
NBB20-12-24-V1  
Part No. 8271  
Made in Germany

# Reduction Factor 1 Sensors

## Identical Switching for All Metals

More flexible machine design and reduced production, plant, and management costs due to long and constant switching distances for all metals: reduction factor 1 sensors are perfect for applications that involve a variety of target metal types.

### Inductive Sensors—Wear-Free Detection of Metal Objects

Noncontact inductive sensors can detect metal objects through their electromagnetic field. Designed without moving components, sensors are not subject to mechanical wear, and their reliability and long service life speak for themselves. Sensors come in an almost unlimited variety of cylindrical and cube-style designs, allowing a style to be chosen that is compatible with the machine design.

### Adaptability—Even in Applications with Multiple Target Types

Starting with steel, the switching distances of conventional inductive sensors are reduced, metal to metal, by a defined reduction factor. This is not the case with reduction factor 1 sensors, which offer identical switching distances for all metals with a single sensor. This allows much more flexibility in machine design and use in applications with multiple target metals. By using only one sensor instead of several, procurement, storage, and administration costs are reduced. In addition, reduction factor 1 sensors offer high magnetic field immunity for use in weld cell environments.

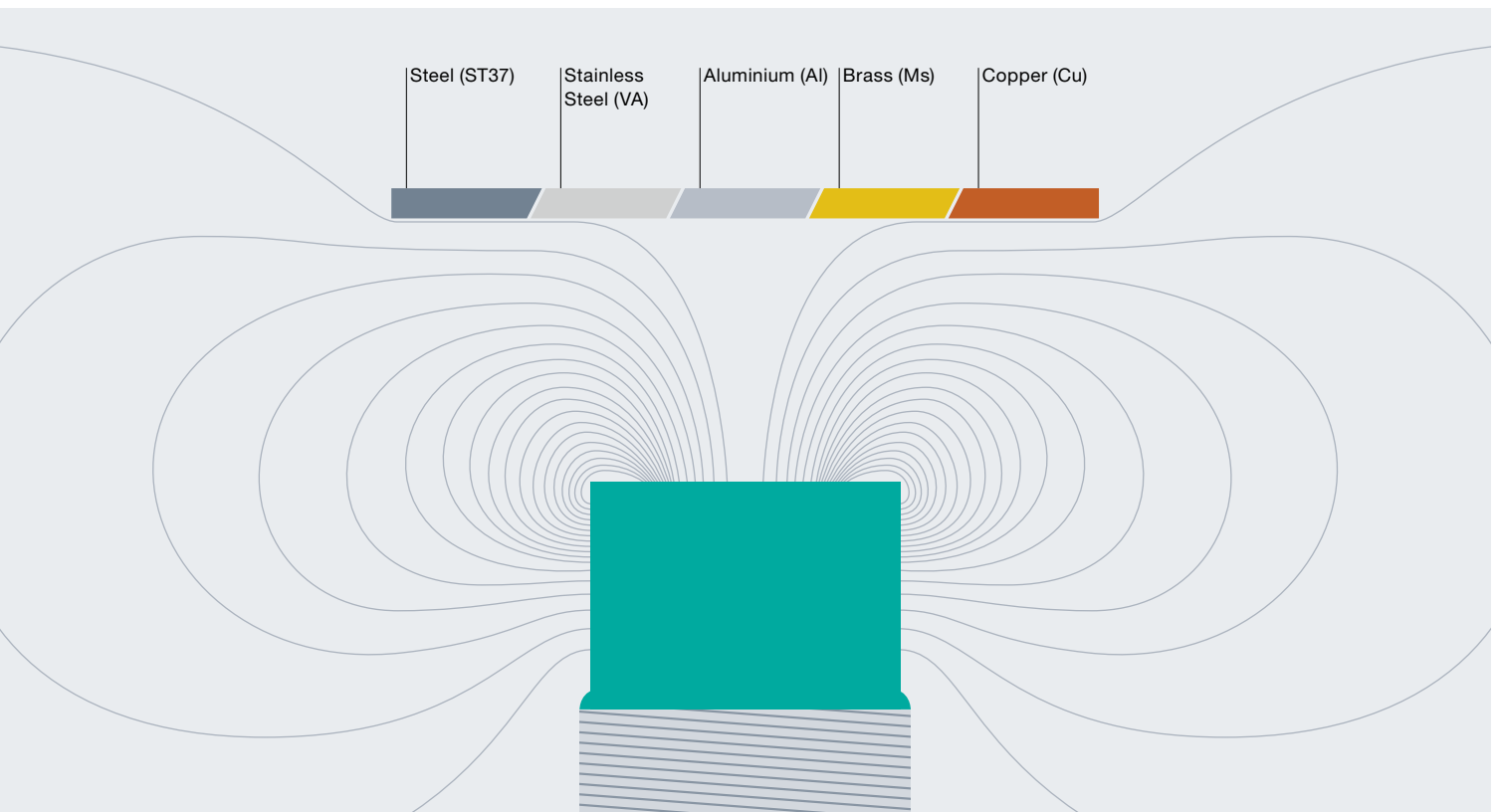

Non-flush reduction factor 1 sensors offer identical switching distances for all metals

### Standard, Weld-Immune, and Chemical-Resistant—Reliable in All Areas

Pepperl+Fuchs’ broad portfolio of reduction factor 1 sensors enables maximum flexibility in automation machinery design. This is made possible by industry-friendly cylindrical and cube-style designs, cabled versions, as well as IO-Link, weld-resistant, and chemical-resistant versions for especially harsh applications. Pepperl+Fuchs’ technological expertise and years of experience as a pioneer in inductive sensor technology are beneficial to users interested in custom solutions.

### Highlights

- Complete IO-Link solution from a single source: sensors, masters, and infrastructure
- Smart maintenance via stability alarm and temperature indicator
- Flexible—a broad portfolio of sensors with identical switching distance, regardless of a target’s material
- Rugged, weld-immune sensors with IP68/IP69K protection for harsh industrial environments

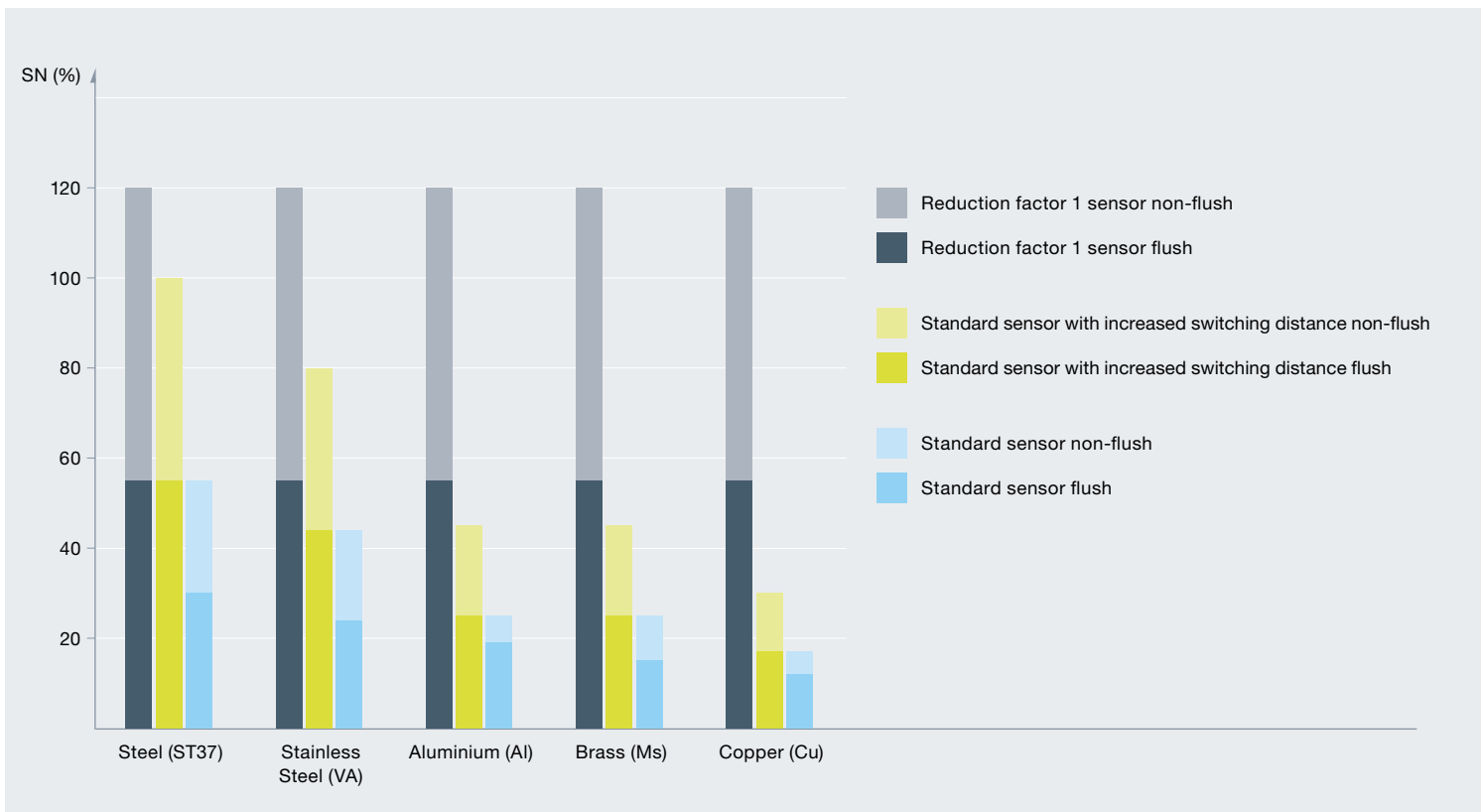

Comparing standard sensors and reduction factor 1 sensors



# Reduction Factor 1 Sensors with IO-Link

## The Standard for Long-Term Solutions

IO-Link stands for sustainable technology, cost reduction, and comprehensive device diagnostics down to the sensor level. Pepperl+Fuchs' IO-Link portfolio offers a complete portfolio from a single source and provides flexible solutions to a wide range of applications.

In addition to the technological benefits of reduction factor 1 sensors, the IO-Link models offer a range of functions for completely new applications in the field of inductive sensors:

- **Identification and diagnostics**—Access to device-specific information directly from the sensor
- **Automatic configuration**—Standard or double switching distance, NO or NC contact
- **Switch point mode with stability alarm**—Monitoring an assured operating distance
- **Window mode with stability alarm**—Detection of unintended proximity to an object
- **Temperature indicator**—Preset temperature thresholds for extended diagnostics on the surrounding area
- **Pulse extension**—Reliable detection of fast targets



**Sensorik4.0®—Paving the Way for the Smart Factory**

Equipped with IO-Link, reduction factor 1 sensors pave the way for the fourth industrial revolution. In the Industry 4.0 future of fully networked production systems, communication-ready sensors play a vital role: they send and receive sensor data within production processes and to higher-level local or cloud-based information systems.

To pave the way for Industry 4.0, Pepperl+Fuchs is providing innovative sensor technologies with Sensorik4.0®. They use the standard IO-Link interface to support the digitization of industrial applications.

|   | M12                             | M18                     | M30                       | Varikont L  |
|---|---------------------------------|-------------------------|---------------------------|---|
| <b>IO-Link standard</b>                       | NR*-12GS40-E2-IO-*-V1           | NR*-18GS40-E2-IO-*-V1   | NR*-30GS50-E2-IO-*-V1     | NR*-L3-E2-IO-*-V1   |
| <b>IO-Link weld-immune</b>                    | NR*-12GS40-E2-IO-C-V1           | NR*-18GS40-E2-IO-C-V1   | NR*-30GS50-E2-IO-C-V1     | NR*-L3-E2-IO-C-V1   |
| <b>Switching distance</b>                     |                                 |                         |                           |   |
| flush   | 4 mm                            | 8 mm                    | 15 mm                     | 20 mm   |
| non-flush                                     | 10 mm                           | 15 mm                   | 30 mm                     | 40 mm   |
| <b>Output</b>                                 | 3-wire, PNP, NO/NC programmable |                         |                           |   |
| <b>Housing</b>                                | Threaded sleeve M12 x 1         | Threaded sleeve M18 x 1 | Threaded sleeve M30 x 1.5 | 40 x 40 x 40 mm (Varikont L)<br>40 x 40 x 120 mm (Varikont) |
| <b>Housing material</b><br><b>weld-immune</b> | Brass PTFE-coated, PPS          |                         |                           | GD-ZnAl4Cu1, PTFE-coated,<br>PA 6 Grivory                   |

See page 12 for more information about weld-immune sensors.



IO-Link V1.1



Standard  
Versions



Weld-Immune  
Versions

# Reduction Factor 1 Sensors with IO-Link

## IO-Link Functions for New Application Possibilities

Identical switching distances for all metals, weld-immune versions in different styles, and IO-Link in every model. Reduction factor 1 sensors simplify installation and optimize automotive process line production.

### Standard Identification with IO-Link

The IO-Link automation interface makes it possible to communicate continuously and share data digitally from the control level to sensors and actuators in the field. Every IO-Link sensor can be easily identified by manufacturer, product number, serial number, and firmware version. This information has been standardized in each sensor and can be read from the control system. If a sensor has to be replaced, the new device can be automatically identified and verified by the control system, avoiding unsuitable sensor installation.

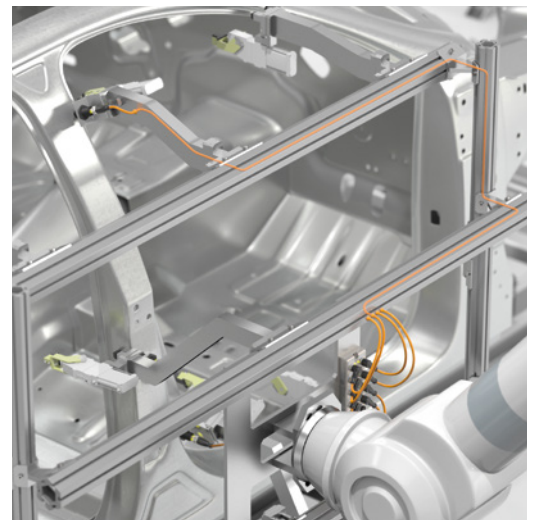



## A Variety of Diagnostic Functions for Smooth Processes

**Switch point mode with stability alarm** monitors the assured operating distance between sensors and targets, monitoring target detection in robotic gripping processes. If there is a problem—including even minimal misalignment of the sensor—it is recognized by the device, registered via IO-Link, and indicated by a blinking LED on the sensor. This makes it possible to conduct maintenance during planned downtime without compromising system availability.

Monitoring the correct operating distance **window mode with stability alarm** enables additional detection and switching reliability. If the robot comes too close to the side panel, it will be detected by the sensor.

## Simplified Setup and Data Storage for Quick Sensor Replacement

Sensor communication is standardized across devices through IO-Link. Sensors no longer need to be programmed manually and can now be configured via the control system. This allows reduction factor 1 sensors with IO-Link to offer every possible grade of freedom during integration and configuration.

Thanks to the data storage function, IO-Link enables on-the-job device replacement. Parameters that were saved during configuration can be loaded onto the replacement sensor using the control system. Individual and manual teach-in is no longer required to configure replacement parts.

### Switch point mode with stability alarm

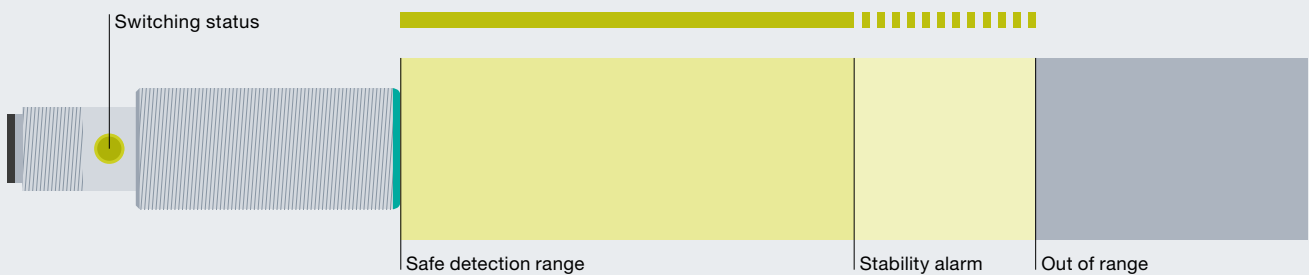

### Window mode with stability alarm

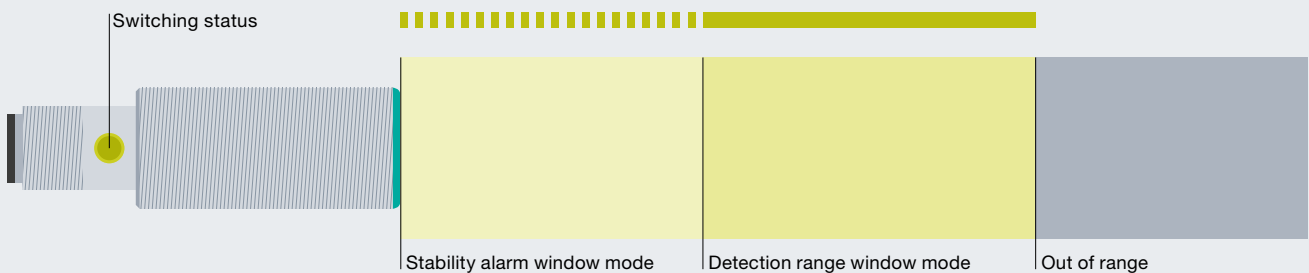

# Reduction Factor 1 Sensors—Standard Versions

## More Flexibility in Machine Design

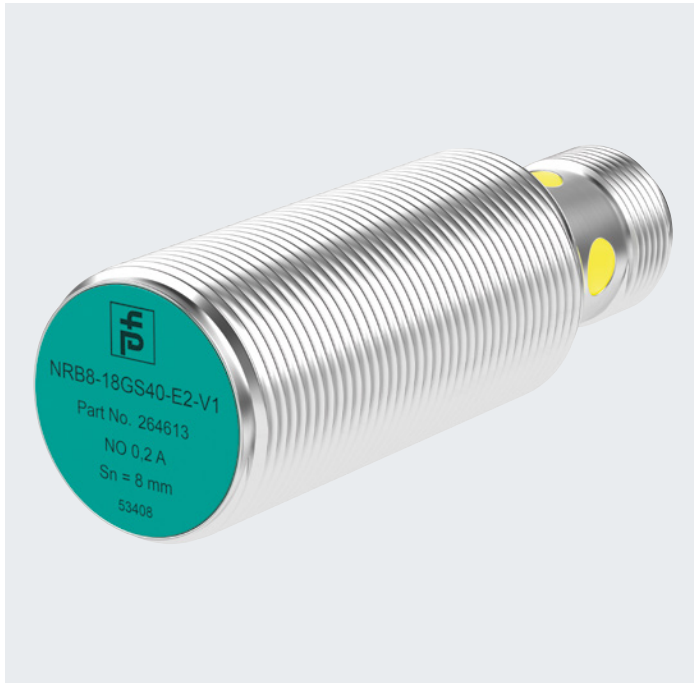





### More Adaptability and Cost-Effectiveness

Reduction factor 1 sensors adapt to the characteristics of different metals and enable identical switching distances, no matter whether the object is steel, stainless steel, aluminum, brass, or copper. This reduces the variety of models in applications with multiple target metals, which results in cost efficiency for storage, purchasing, and administration.

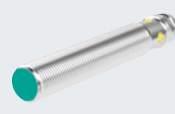
### Highlights

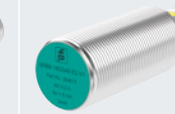
- Incredibly flexible with industry-grade cylindrical and cube-style housings
- Rugged housing made of V2A stainless steel and an impact-resistant, plastic sensing face
- Identical switching distances for all metals with a single sensor

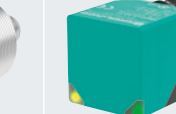
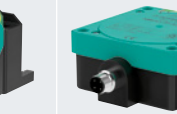
|                            | M8  | M12   | M18   | M30  | Varikont  | FP  |
|----------------------------|---|---|---|--|---|---|
| <b>Order Code</b>          | NR*-8GS40-E2-V3   | NR*-12GS40-E2-V1  | NR*-18GS40-E2-V1  | NR*-30GS50-E2-V1   | NR*-L3-A2-V1  | NR*-FP-A2-P3-V1   |
| <b>Standard</b>            |  |  |  |  |  |  |
| <b>Switching distance</b>  |   |   |   |  |   |   |
| flush                      | 2 mm  | 4 mm  | 8/12 mm   | 15 mm  | 20 mm   | 50 mm   |
| non-flush                  | 6 mm  | 10 mm   | 15 mm   | 30 mm  | 35/40 mm  | 75 mm   |
| <b>Switching frequency</b> |   |   |   |  |   |   |
| flush                      | 4,000 Hz  | 2,400 Hz  | 1,400 Hz  | 750 Hz   | 100 Hz  | 80 Hz   |
| non-flush                  | 2,500 Hz  | 1,500 Hz  | 600 Hz  | 300 Hz   |   | 50 Hz   |
| <b>Output</b>              | 3-wire PNP<br>NO  | 3-wire PNP, NPN NO, NC, 4-wire PNP, NPN complementary                               |   |  |   | 3-wire PNP NO,<br>4-wire PNP<br>complementary   |
| <b>Housing</b>             | Threaded sleeve<br>M8 x 1<br>Smooth body<br>6.5 mm                                  | Threaded sleeve<br>M12 x 1  | Threaded sleeve<br>M18 x 1  | Threaded sleeve<br>M30 x 1.5   | 40 x 40 x 40 mm<br>(Varikont L)<br>40 x 40 x 120 mm<br>(Varikont)                     | 80 x 80 x 40 mm   |
| <b>Housing material</b>    | Stainless steel V2A,<br>LCP   | Stainless steel V2A, PBT  |   |  | GD-ZnAl4Cu1<br>coated, PA 6 Grivory   | PBT/metal   |

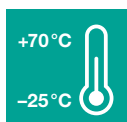

Temperature range



Protection class up to IP68

Selected products. For more models, visit [www.pepperl-fuchs.com/pf-r1](http://www.pepperl-fuchs.com/pf-r1)

## Reliable Skid Control in Automotive Production

In automotive plants, robots weld parts to chassis that are transported to production cells on platforms known as skids. Reduction factor 1 sensors ensure process-compliant skid position in weld cells. Its high switching distance balances potential guiding tolerances on the skid. As soon as the skid reaches the required position, the welding robots in the production cells are triggered to start the welding process for vehicle side and roof components. Inductive reduction factor 1 sensors make it possible to position skids correctly at every station for disruption-free, reliable control of the whole process.

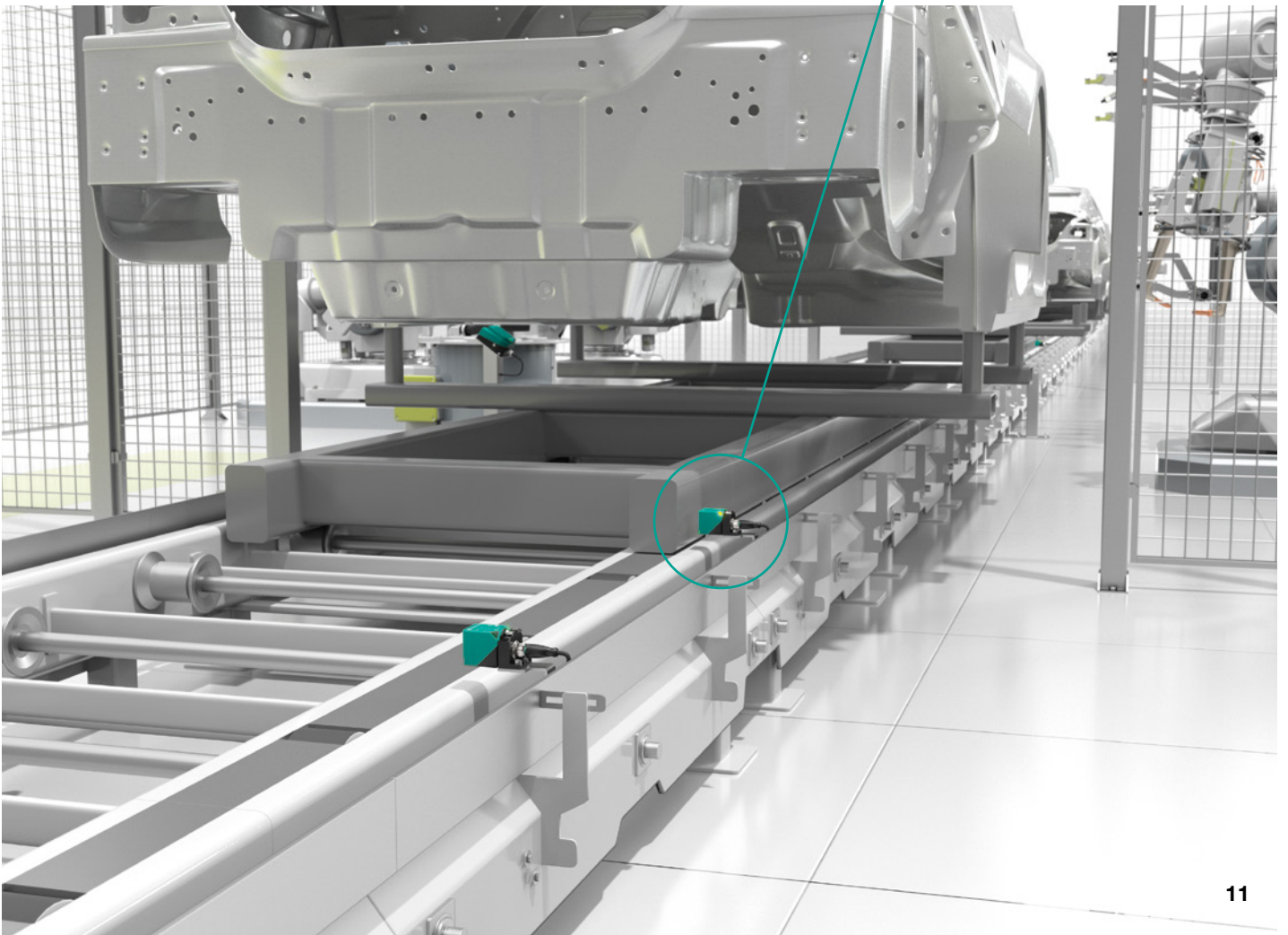

# Reduction Factor 1 Sensors—Weld-Immune Versions Extremely Rugged, Even in Harsh Conditions



## Electromagnetic Field Resistant and Weld-Immune

Weld-immune sensors with IP68 protection are the ideal detection solution in welding and other harsh process environments. An air-coil system and advanced electronics make the sensors resistant to electromagnetic fields that they might encounter during the welding process or influence from variable frequency drive control systems. The housing design of the various styles ensures longevity and availability, and the brass casing of the cylindrical sensors are coated with PTFE, which protects against weld sparks and metal shavings, just as the cube-style version is made of metal or special weld-immune plastic.

|                            | M8  | M12   | M18   | M30  | Varikont  | FP  |
|----------------------------|---|---|---|--|---|---|
| <b>Order Code</b>          | NR*-8GM40-E2-C-V1   | NR*-12GM40-E2-C-V1  | NR*-18GM40-E2-C-V1  | NR*-30GM50-E2-C-V1   | NR*-L3-A2-C-V1  | NR*-FP-A2-C-P3-V1   |
| <b>Weld-immune</b>         |  |  |  |  |  |  |
| <b>Switching distance</b>  |   |   |   |  |   |   |
| flush                      | 2 mm  | 4 mm  | 8/12 mm   | 15 mm  | 20 mm   | 50 mm   |
| non-flush                  | 6 mm  | 10 mm   | 15 mm   | 30 mm  | 35/40 mm  | 75 mm   |
| <b>Switching frequency</b> |   |   |   |  |   |   |
| flush                      | 1,000 Hz  | 2,000 Hz  | 600 Hz  | 750 Hz   | 100 Hz  | 1 Hz  |
| non-flush                  | 400 Hz  | 1,000 Hz  | 500 Hz  | 300 Hz   |   |   |
| <b>Output</b>              | 3-wire PNP NO   | 3-wire PNP, NPN NO/NC   |   |  |   | 3-wire PNP NO, 4-wire PNP complementary   |
| <b>Housing</b>             | Threaded sleeve M8 x 1  | Threaded sleeve M12 x 1   | Threaded sleeve M18 x 1   | Threaded sleeve M30 x 1.5  | 40 x 40 x 40 mm (Varikont L)<br>40 x 40 x 120 mm (Varikont)                           | 80 x 80 x 40 mm   |
| <b>Housing material</b>    | Brass PTFE-coated, LCP  | Brass PTFE-coated, PPS  |   |  | GD-ZnAl4Cu1, PTFE-coated, PA 6 Grivory  | PBT/metal PTFE-coated   |



Temperature range



Protection class up to IP68



Weld-Immune Versions

Selected products. For more models, visit [www.pepperl-fuchs.com/pf-r1w](http://www.pepperl-fuchs.com/pf-r1w)



## Highlights

- Reliable switching with electromagnetic field resistance
- Especially durable due to rugged IP67 and IP68 housings with tough PTFE coating or weld-immune plastic sensing face
- Available with IO-Link
- Proven technology that has solved applications around the world

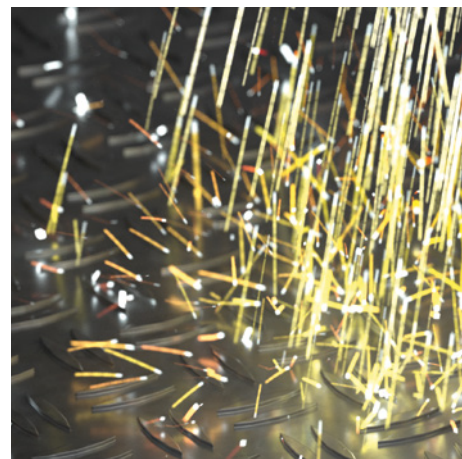
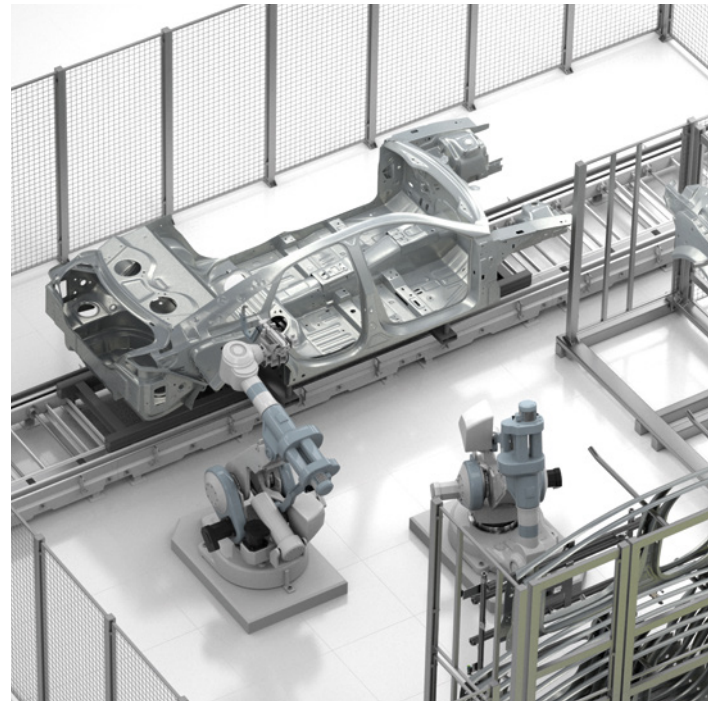
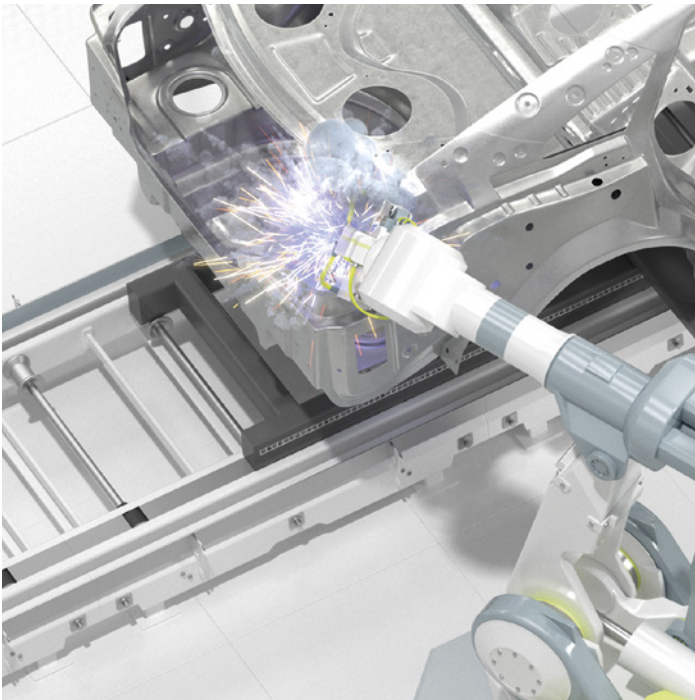



# Reduction Factor 1 Sensors—Stainless Steel Versions

## Durable Sensors for the Food Industry

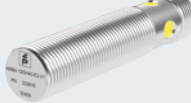

### Especially Robust for Wet Areas

Cleaning agents, disinfectants, and cleaning procedures that involve high pressure and temperatures place unique demands on sensors in the food and beverage industry. Reduction factor 1 sensors with V4A stainless steel housings made of FDA-certified LCP withstand extreme conditions when detecting metal food containers. They are rust-free and resistant to cleaning agents used to clean and disinfect the outside of machines in the food industry. With IP68/IP69K protection, these inductive sensors fulfill the challenging requirements in washdown areas.

|                            | M8  | M12   | M18  | M30   |
|----------------------------|---|---|--|---|
| <b>Order Code</b>          | NR*-8GH40-E2-V1   | NR*-12GH40-E2-V1  | NR*-18GH40-E2-V1   | NR*-30GH50-E2-V1  |
| <b>Stainless steel V4A</b> |  |  |  |  |
| <b>Switching distance</b>  |   |   |  |   |
| flush                      | 2 mm  | 4 mm  | 8 mm   | 15 mm   |
| non-flush                  | 6 mm  | 10 mm   | 15 mm  | 30 mm   |
| <b>Switching frequency</b> |   |   |  |   |
| flush                      | 4,000 Hz  | 2,000 Hz  | 1,500 Hz   | 750 Hz  |
| non-flush                  | 2,500 Hz  | 1,500 Hz  | 500 Hz   | 300 Hz  |
| <b>Output</b>              | 3-wire PNP NO   |   | 3-wire PNP, NPN NO, NC   |   |
| <b>Housing</b>             | Threaded sleeve M8 x 1  | Threaded sleeve M12 x 1   | Threaded sleeve M18 x 1  | Threaded sleeve M30 x 1.5   |

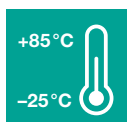

Temperature range



Protection class up to IP68/IP69K



Stainless steel V4A

Selected products. For more models, visit [www.pepperl-fuchs.com/pf-r1v4a](http://www.pepperl-fuchs.com/pf-r1v4a)

## Highlights

- Resistant to aggressive substances and cleaning solutions
- For reliable position monitoring and detection of metal food containers
- Use of food-safe and FDA-certified materials

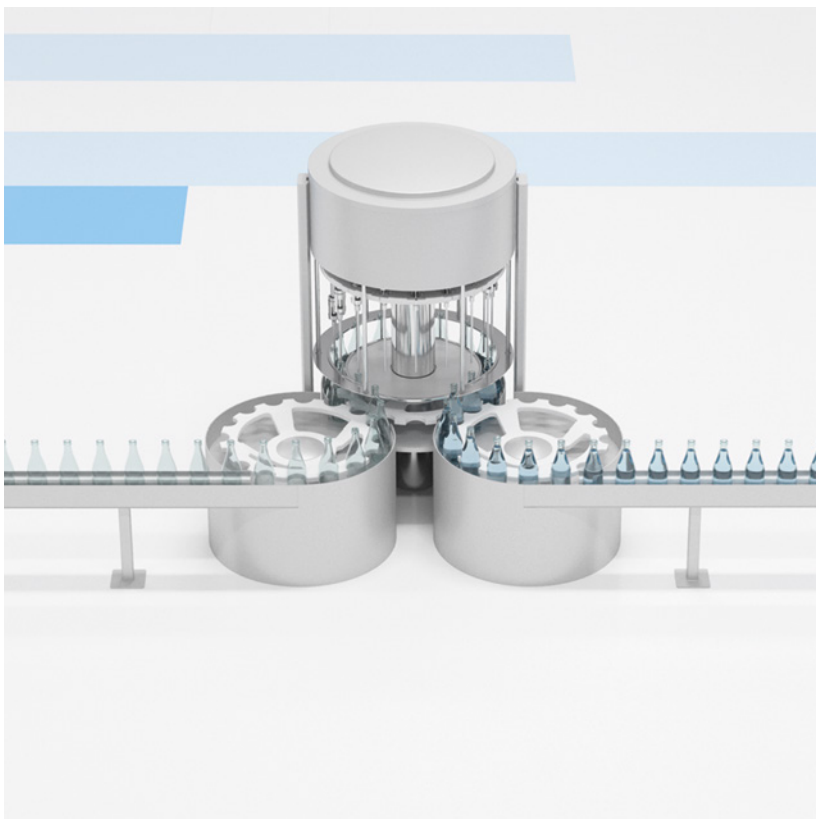
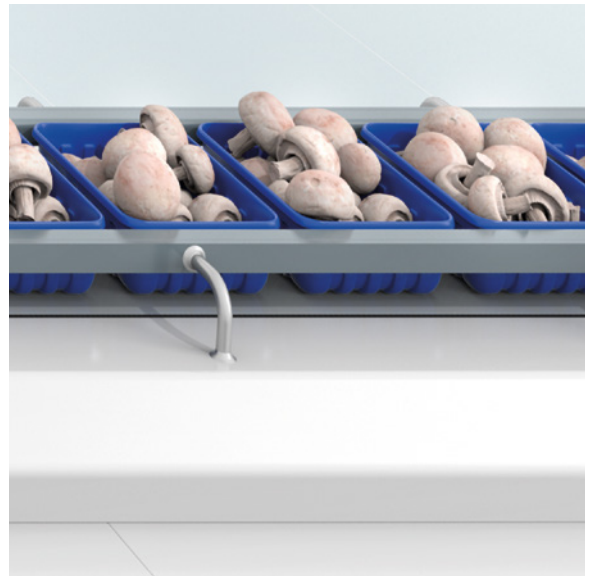

# Your automation, our passion.

## Explosion Protection

- Intrinsic Safety Barriers
- Signal Conditioners
- FieldConnex® Fieldbus
- Remote I/O Systems
- Electrical Ex Equipment
- Purge and Pressurization
- Industrial HMI
- Mobile Computing and Communications
- HART Interface Solutions
- Surge Protection
- Wireless Solutions
- Level Measurement

## Industrial Sensors

- Proximity Sensors
- Photoelectric Sensors
- Industrial Vision
- Ultrasonic Sensors
- Rotary Encoders
- Positioning Systems
- Inclination and Acceleration Sensors
- Fieldbus Modules
- AS-Interface
- Identification Systems
- Displays and Signal Processing
- Connectivity

### Pepperl+Fuchs Quality

Download our latest policy here:

[www.pepperl-fuchs.com/quality](http://www.pepperl-fuchs.com/quality)

