



MEASURING WITH INTELLIGENCE

LGM MEASURING LIGHT GRID

Measuring with Intelligence – Material Handling in All Markets

Designed for a wide range of material handling applications, the new LGM Series measuring light grids come with standard features that place it well above other measuring light grids on the market. Complex single-beam evaluations for standard tasks and cumbersome configuration are replaced with 16 integrated measuring options. Users select the optimum mode for their application and receive direct measurement values in millimeters via IO-Link.

Intelligent Features for Better Performance

The LGM light grids have an ultra-low profile to fit into tight spaces. Innovative, tool-free mounting accessories make installation, alignment, and replacement fast and easy.

This series has a three-way beam crossover for higher resolution with no impact on response time and field heights up to 3200 mm. The IP67 aluminum housing withstands harsh environmental conditions even at cold-storage temperatures, down to -30°C .

New Approaches for



Highlights at a Glance

- Choose among 16 integrated measuring functions
- Direct measurement in millimeters – no complex conversions
- Integrated IO-Link interface enables easy setup and evaluation
- Slim lightweight housing provides fast, flexible installation
- IP67 protection, also suitable for cold storage applications
- Beam crossover provides higher resolution with no increase in response time

Technical Data

Product	LGM
Effective operating distance	0.3 m ... 6 m
Field height	min. 100 mm, max. 3200 mm (in 100 mm increments)
Beam spacing	8 mm, 17 mm, 25 mm, 50 mm
Beam crossover	3-way beam crossover
Optical resolution	Beam crossover disabled: 8, 17, 25, 50 mm Beam crossover enabled: 4, 8.5, 12.5, 25 mm
Interface type	IO-Link (Version 1.0, process data bandwidth 16 bit)
Function input	Emitter: test/range input Receiver: external configuration
Ambient light limit	50,000 Lux
Temperature range	-30 °C ... +60 °C (-22 °F ... +140 °F)
Degree of protection	IP67
Connection	200 mm fixed cable with M12 plug (pigtail)
Housing cross section	20 mm x 30 mm

Easy Setup and Evaluation with

IO-Link enables you to utilize all of the intelligent resources that are available with the LGM light grids – all data at the sensor level, from the sensor to the PLC, is continuously visible. And the light grids are system independent and can be used on any IO-Link master.

Measurement Values Provided in Millimeters Enable Easy Integration

IO-Link allows the controller to configure and communicate with the light grid. Data is available to higher systems without any limitations. In addition to digitally transmitting measurements with a cycle time of 2.3 ms, IO-Link enables convenient commissioning and maintenance from the control level. Users simply select the appropriate measuring function according to their application requirements. There are no complex single-beam calculations to do; the LGM light grids are ready to use right out of the box.

To make LGM even easier to use, Pepperl+Fuchs offers a DTM (Device Type Manager) – a graphical user interface for easier visualization and interpretation of configuration, parameter, and diagnostic data.

Flexible Parameterization, Configuration, and Diagnostics

IO-Link enables easy setup, parameterization, and remote configuration from the PLC level downwards. Fast and easy setup and change of parameters, measurement functions, and operation modes are quickly made during normal operation.

Intelligent parameterization and configuration enable users to quickly change the settings for a variety of devices. Rather than following a system maintenance schedule, extensive diagnostic information during operation allows maintenance on demand and eliminates system downtime.



IO-Link

IO-Link Interface

The Right Measurement Function for Every Application

Users can choose from 16 integrated operation modes for object measurement, object identification, or object counting.

Flexible Object Measurement

Nine measurement parameter configurations are available for object measurements, e.g., object height measurement, lowest or highest object position, or sum and average values.

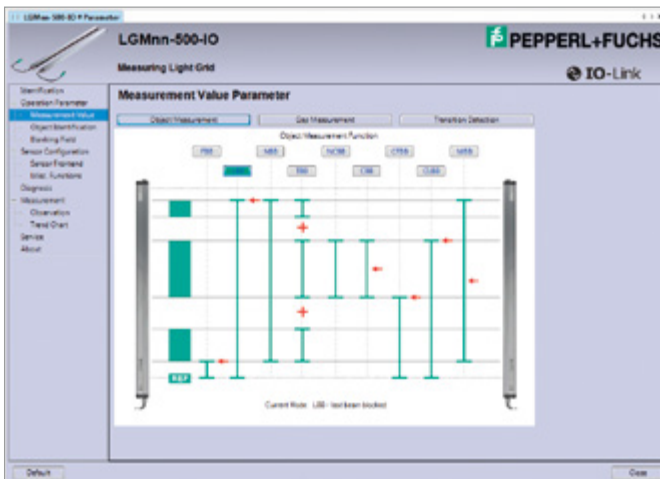

Example:

FBB: First Beam Blocked (overall) = lowest object position across all subobjects [in mm]

LBB: Last Beam Blocked (overall) = highest object position across all subobjects [in mm]

NBB: Number of Beams Blocked (overall) = object height across all subobjects, $NBB = LBB - FBB$ [in mm]

TBB: Total Beams Blocked = object height as the total height of all subobjects [in mm]

Reliable Object Identification

In addition to the object measurement functions, objects can be taught-in and identified according to their geometry. There are six different object identification parameters to choose from.



Example:

OBJS: Static Object Identification = an object is recognized if its profile and position match what was taught

OBJF: Floating Object Identification = a floating object is recognized if its profile matches what was taught

More Application Diversity with

Object Height Measurement for Optimal Use of Storage Areas

Object height measurement is a common application in material handling. The LGM measuring light grids not only identify objects, they measure them accurately down to the millimeter for the efficient use of storage areas, e.g., the height of goods on a pallet can be measured before they are stored.

The LBB (Last Beam Blocked) measurement function determines the highest object position when a pallet with goods breaks the top light beams. The measurement value is provided to the PLC in millimeters via the IO-Link interface.

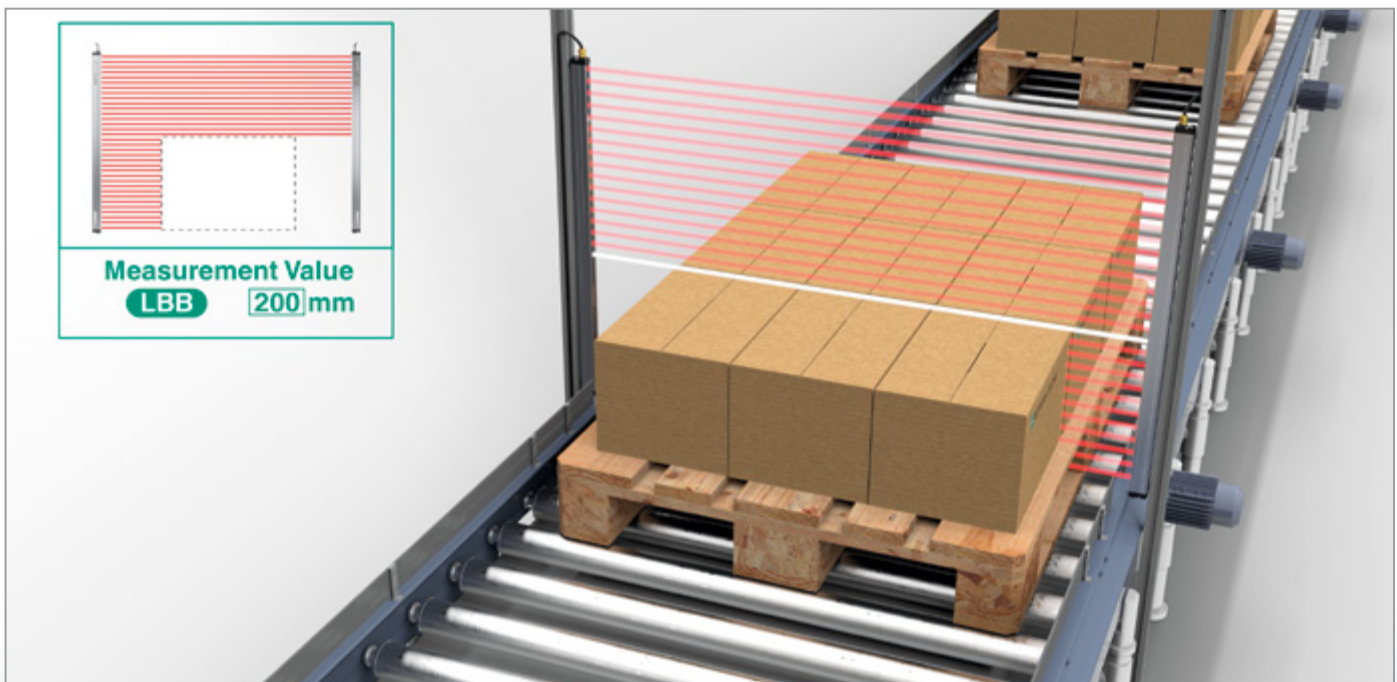
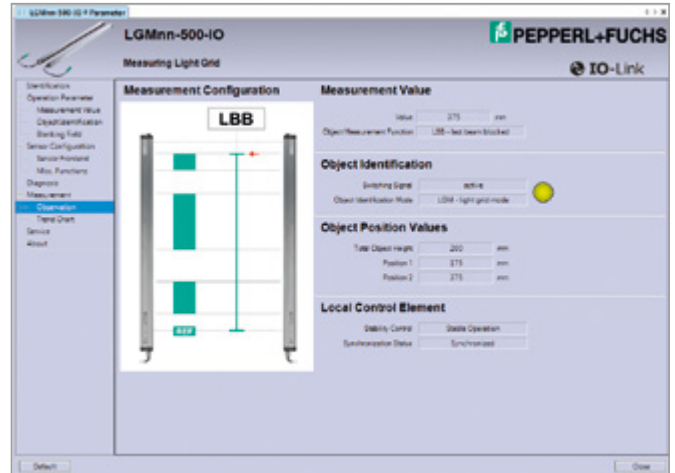

Reliable Measurement and Identifi

Selecting and Positioning Objects for More Efficient Processes

Products are assigned to distribution paths based on accurate object measurements provided by the LGM. No complicated measurement systems are required.

With the NBB (Number of Beams Blocked) measurement function, object size is based on the difference between the highest and the lowest beam blocked. The measurement value that is provided by IO-Link directly to the PLC determines the distribution path.

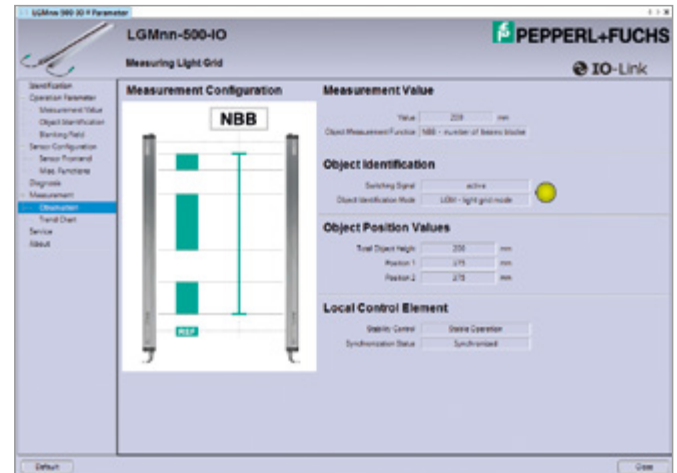

Combining Horizontal and Vertical Measurements

The LGM's measurement options can easily be combined for volume measurement. Mounting the LGM light grids vertically and horizontally on the conveyor enables height and width measurements.

Measurement values in millimeters are sent directly to the PLC to help determine a more efficient use of storage spaces or transportation space requirements.

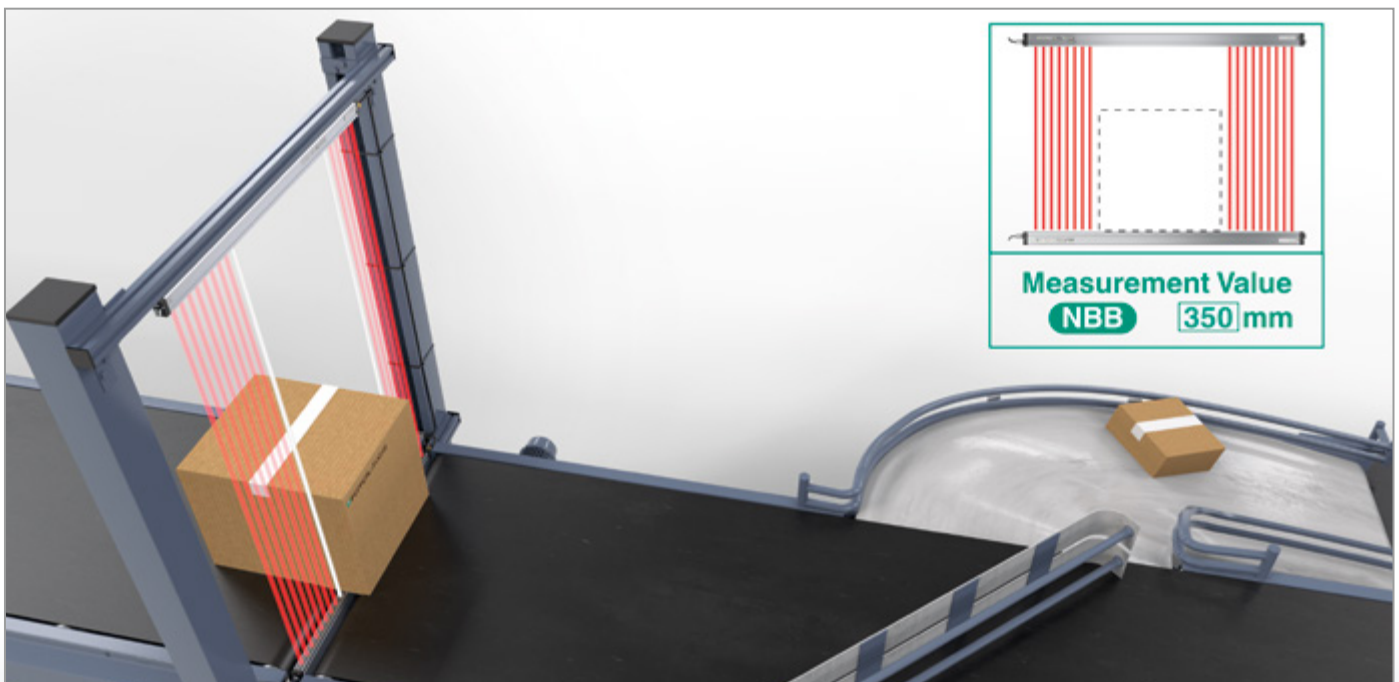

fication

Object Identification Increases Reliability

In addition to object measurement, the LGM light grids can also detect and identify objects according to their shape and geometry. Holes and gaps are easily identified and measured by selecting the OBJS (Static Object Identification) or the OBJF (Floating Object Identification) mode via the IO-Link setup.

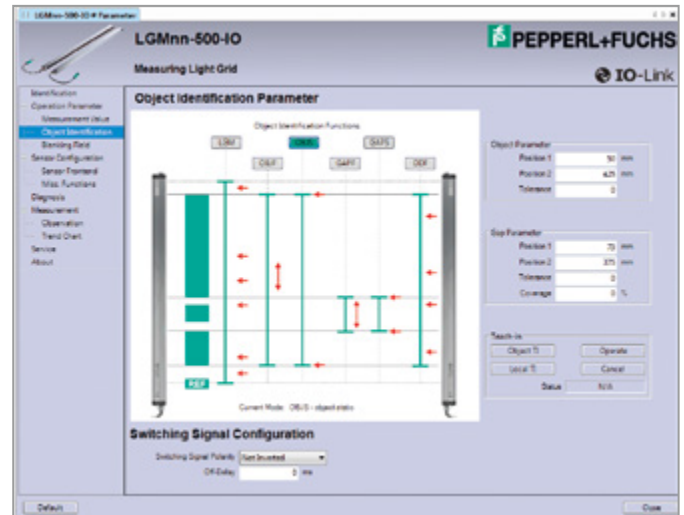

Beam Crossing for Higher Precision

Three-way beam crossover increases the resolution with no increase in response time, guaranteeing greater precision at the same speed of operation.

The LGM measuring light grid also allows hole and gap measurements in combination with object identification in order to correctly identify and measure objects for reliable allocation in the production process.

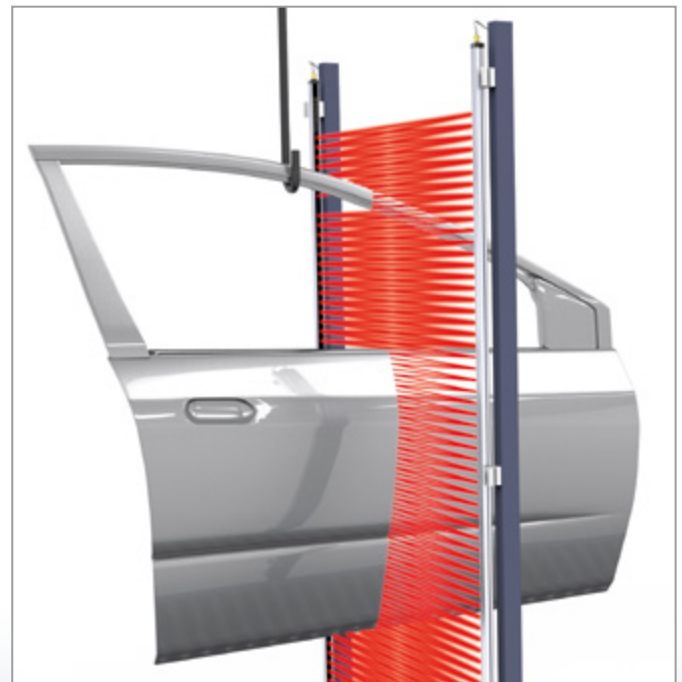
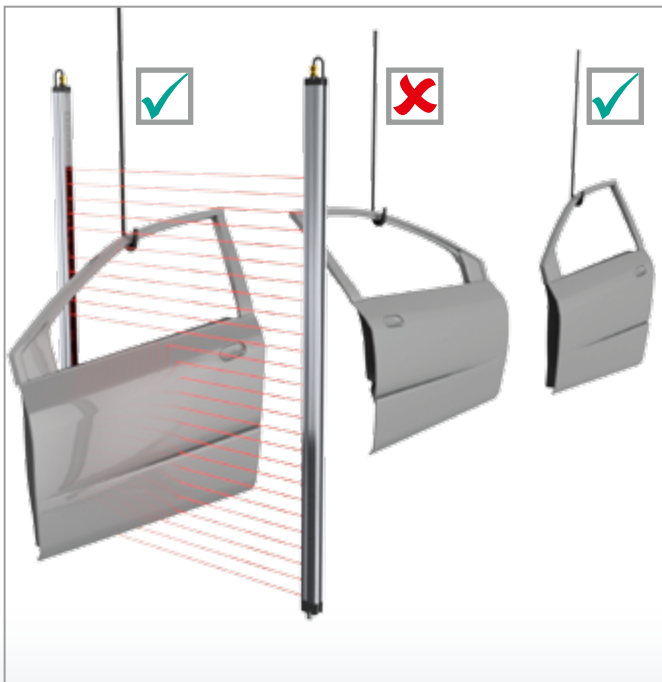

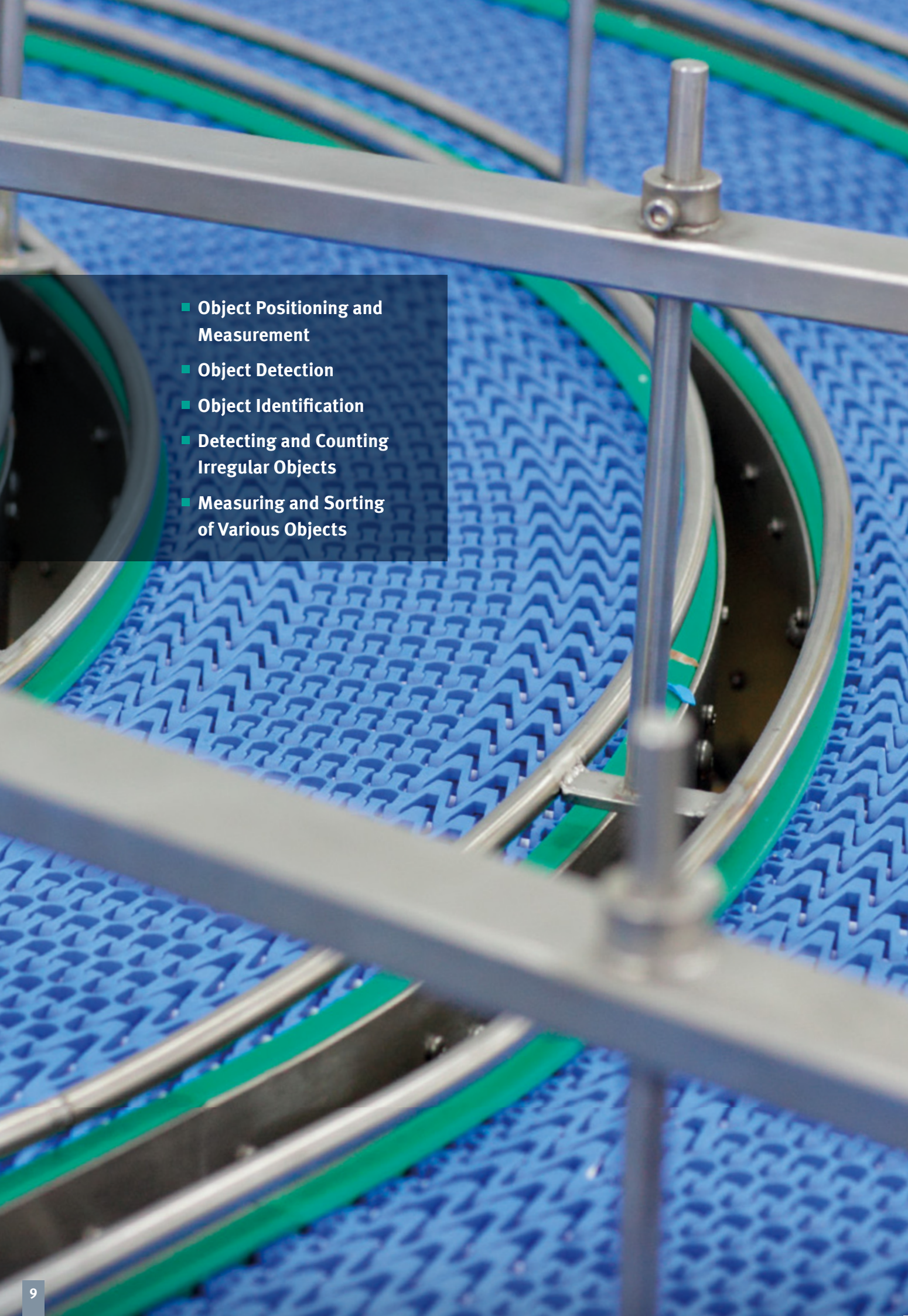
- 
- Object Positioning and Measurement
 - Object Detection
 - Object Identification
 - Detecting and Counting Irregular Objects
 - Measuring and Sorting of Various Objects

YOUR APPLICATION. OUR CHALLENGE.

EXPLOSION PROTECTION

- Intrinsically Safe Barriers
- Signal Conditioners
- Fieldbus Infrastructure
- Remote I/O Systems
- HART Interface Solutions
- Wireless Solutions
- Level Measurement
- Purge and Pressurization Systems
- Industrial Monitors and HMI Solutions
- Electrical Explosion Protection Equipment
- Solutions for Explosion Protection

INDUSTRIAL SENSORS

- Proximity Sensors
- Photoelectric Sensors
- Industrial Vision
- Ultrasonic Sensors
- Rotary Encoders
- Positioning Systems
- Inclination and Acceleration Sensors
- AS-Interface
- Identification Systems
- Logic Control Units



www.pepperl-fuchs.com

 **PEPPERL+FUCHS**